

RMD75-UW Series ◊ Plug & Play Railway

75W ◊ Ultra-Wide Input 16.8V-137.5VDC

FEATURES

- Fully EN50155 compliant, no external circuits
- Ultra-wide input range 11:1 reduces product variety
- Excellent efficiency, lowest power loss, full lifetime
- Active input reverse polarity protection
- Active inrush current limitation - network protection
- 10ms hold-up time over the entire input range
- Reinforced insulation, 5mm air/creepage distances
- Trim-output for long cable runs or battery charging
- Parallel and redundant operation
- 20% Peak load capability to 90W for 10s
- Remote (on/off) and DC OK signal
- 2 years warranty



APPLICATIONS

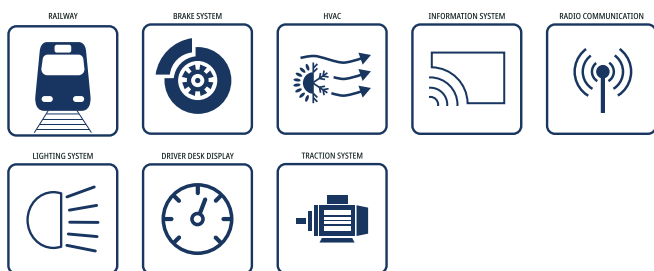

SAFETY & EMC



DESCRIPTION

The chassis mountable RMD75-UW series DC/DC converter is designed for railway and transportation applications and is compliant with all relevant standards: EN50155, EN50121-3-2, DB-EMV06, EN50124-1, EN50125-1, EN61373 1B, EN62368-1, EN45545-2. The unit is designed with 11:1 input voltage range to cover the input voltages from 14.4VDC up to 154VDC for nominal 24, 36, 48, 72 and 110V in one range for all applications - on every vehicle worldwide. These isolated and regulated outputs works with a reinforced isolation system. Due to the base plate mounting the unit operates with full power within the wide temperature for OT4+ST1&ST2 class from -40°C to +85°C and no additional cooling systems are necessary. Input reverse polarity protection, inrush current limitation, 10ms hold-up time, remote control, and output OR-ing diode and efficiency of up to 92% round up the functionality of this fully railway compliant Plug&Play unit.

SELECTION GUIDE

Part Number	Input Voltage Range [VDC]	Output Voltage nom. [VDC]	Output Current max. ⁽¹⁾ [A]	Efficiency typ. [%]	continuous Output Power [W]
RMD75-110-12SUW *coming soon	16.8-137.5	12	7.5	91	75
RMD75-110-24SUW	16.8-137.5	24	3.75	92.5	75

Note1: Refer to „Peak load Capability“

Note2: Efficiency is tested at input voltage 110VDC and full load at +25°C ambient.

MODEL NUMBERING

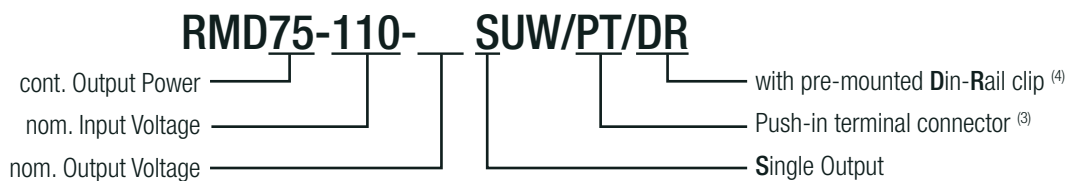

Note3: add suffix **"/PT"** for push-in terminal connector and changer contact instead open collector PG function, no output voltage trimming function; without suffix = standard connector, open collector PG and output voltage trimming function. Refer to **„Dimension Drawing "/PT" Version (mm)“**

Note4: add suffix **"/DR"** for module with pre-mounted din-rail clip on backside. Refer to **„Dimension Drawing "/DR" Version (mm)“**

Note5: Add suffix **"/PT/DR"** for version with push-in terminal connector and pre-mounted DIN-rail clip on the backside

ORDERING INFORMATION

Model	Nom. Output Voltage	Power Good	Connector	Trimming function	Peak Power
RMD75-110-24SUW	24VDC	open collector	standard connector	yes (21.6-26.4VDC)	90W/10sec max.
RMD75-110-24SUW/PT	24VDC	changer contact	WAGO cage clamp	no	90W/10sec max.
RMD75-110-24SUW/DR	24VDC	open collector	standard connector	yes (21.6-26.4VDC)	no
RMD75-110-24SUW/PT/DR	24VDC	changer contact	WAGO cage clamp	no	no

BASIC CHARACTERISTICS (measured @ T_{AMB}= 25°C, nom. V_{IN}, full load and after warm-up unless otherwise stated)

Parameter	Conditions	Min.	Typ.	Max.	
Input Voltage Range	nom. V _{IN} = 24, 36, 48, 72, 110VDC	16.8VDC		137.5VDC	
	refer to „Input Voltage Range“	according to EN 50155	100ms max	14.4VDC	16.8VDC
			1s max.	137.5VDC	154VDC
Input Capacitance	internal		4µF		
Under Voltage Lockout	rising edge	15VDC		16VDC	
	falling edge			14.4VDC	
	hysteresis		1VDC		
Input Current	V _{IN} =16.8VDC	5.1A	5.45A	7A	
	V _{IN} =24VDC		3.5A	4.7A	
	V _{IN} = 110VDC		0.75A	1A	
	V _{IN} = 137.5VDC			0.8A	
Inrush Current	active inrush current limitation (<3.5 x I _{nom})			14A	
No Load Power Consumption	V _{IN} = 16.8VDC		1.9W		
	V _{IN} = 110VDC		1.4W		
Standby Power (shutdown by remote)				1W	
Output Current Range	continuous operation	RMD75-110-12SUW	0A	6.25A	
		RMD75-110-24SUW	0A	3.125A	
	10s max., refer to „Peak load Capability“ T _{AMB} = 70°C max.	RMD75-110-12SUW		7.5A	
		RMD75-110-24SUW		3.75A	
Nominal Output Voltage (factory set)	RMD75-110-12SUW		12VDC		
	RMD75-110-24SUW		24VDC		
Output Voltage Trimming (not available for /PT option)	RMD75-110-12SUW	10.8VDC		13.2VDC	
	RMD75-110-24SUW	21.6VDC		26.4VDC	
Minimum Load		0%			
Start-up time	V _{IN} = 24VDC			1s	
	V _{IN} = 110VDC			1s	
	by using CTRL ON/OFF function			0.2s	
Rise time	V _{IN} = 24VDC, 110VDC			100ms	

RMD75-UW Series / Plug & Play Railway

75W / Ultra-Wide Input 16.8V-137.5VDC

BASIC CHARACTERISTICS (measured @ $T_{AMB} = 25^{\circ}C$, nom. V_{IN} , full load and after warm-up unless otherwise stated)

Parameter	Condition	Min.	Typ.	Max.
Hold-up time	$V_{IN} = 16.8VDC$	10ms		
	$V_{IN} = 110VDC$	30ms		
ON/OFF CTRL	DC-DC ON	open or connected to $+V_{IN}$		
	DC-DC OFF	connected to $-V_{IN}$		
Input Current of CTRL pin	DC-DC ON			10mA
Internal Operating Frequency			88kHz	
Output Ripple and Noise	10 μ F electrolytic capacitor in parallel across the output (low ESR)	ripple	1% of V_{OUT}	
		noise	2% of V_{OUT}	
Maximum Capacitive Load	RMD75-110-24SUW		4000 μ F	

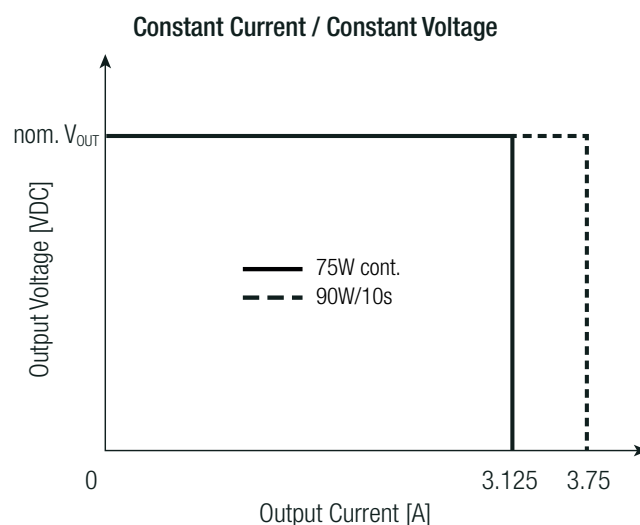
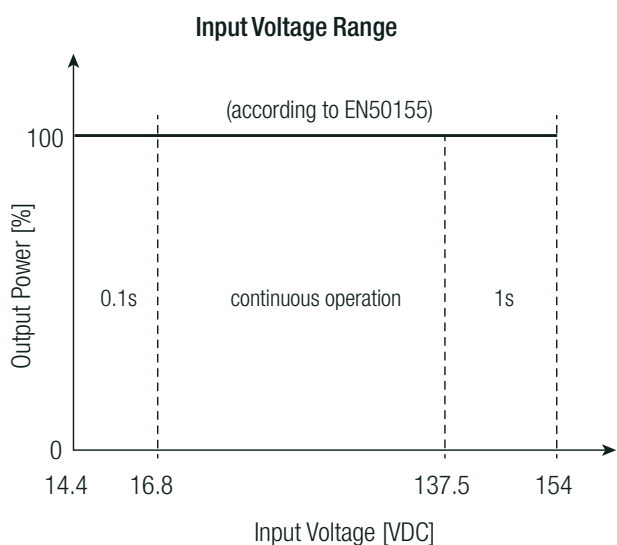

RMD75-110-24SUW

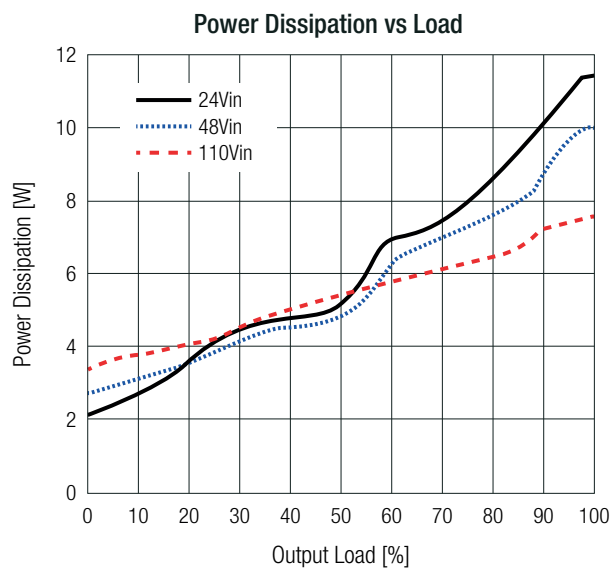
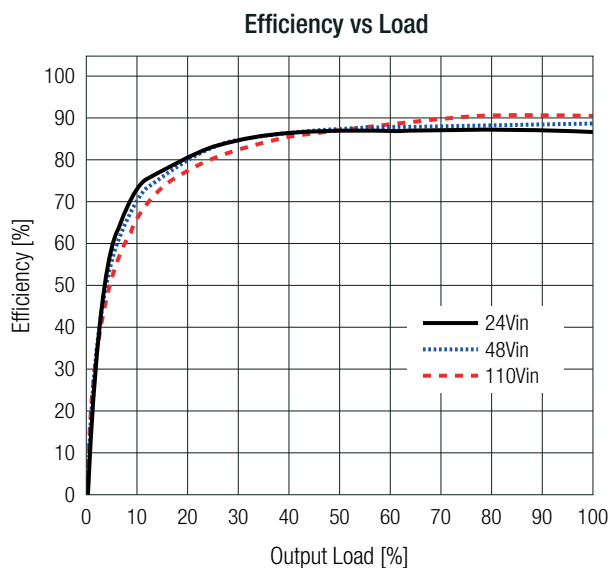

OUTPUT VOLTAGE TRIMMING

The output voltage of the RMD40-UW can be trimmed between ±10% by using an external trim resistor. The /PT version does not support this feature. The values for the trim resistor are according to standard E96 values; therefore, the specified voltage may slightly vary. Resistor values may be calculated with the following equation:

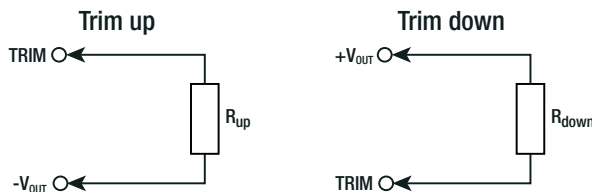

V_{out_nom} = nominal output voltage [VDC]

V_{out_set} = trimmed output voltage [VDC]

V_{ref} = reference voltage [VDC]

R_{up} = trim up resistor [Ω]

R_{down} = trim down resistor [Ω]

k_u = trim up factor []

k_d = trim down factor []

Model	R_1 [Ω]	R_2 [Ω]	R_3 [Ω]	V_{ref} [VDC]
RMD75-110-12SUW	16k	4k2	7k8	2.5
RMD75-110-24SUW	35k3	4k1		

Calculations:

$$k_u \cong \left[\frac{V_{REF}}{V_{OUTset} - V_{REF}} \right] \times R_1 \quad R_{up} \cong \left[\frac{k_u \times R_2}{R_2 - k_u} \right] - R_3$$

$$k_d \cong \left[\frac{V_{OUTset} - V_{REF}}{V_{REF}} \right] \times R_2 \quad R_{down} \cong \left[\frac{k_d \times R_1}{(R_1 - k_d)} \right] - R_3$$

Practical Example trim up +10% for RMD75-110-24SUW

$V_{out_set} = 26.4VDC$; $V_{out_nom} = 24VDC$

$$k_u = \left[\frac{2.5V}{26.4V - 2.5V} \right] \times 35k3 = 3692.47$$

$$R_{up} = \left[\frac{3692.47 \times 4k1\Omega}{4k1\Omega - 3692.47} \right] - 7k8\Omega = 29348.49\Omega$$

R_{up} according to E96 \approx **29k4 Ω**

Practical Example trim down -10% for RMD75-110-24SUW

$V_{out_set} = 21.6VDC$; $V_{out_nom} = 24VDC$

$$k_d = \left[\frac{(21.6V - 2.5V)}{2.5V} \right] \times 4k1 = 31324$$

$$R_{down} = \left[\frac{31324 \times 35k3\Omega}{35k3\Omega - 31324} \right] - 7k8\Omega = 270302.92\Omega$$

R_{down} according to E96 \approx **267k Ω**

RMD75-110-12SUW

Trim up	1	2	3	4	5	6	7	8	9	10	[%]
$V_{out_set} =$	12.12	12.24	12.36	12.48	12.6	12.72	12.84	12.96	13.08	13.2	[VDC]
R_{up} (E96) \approx	287k	150k	100k	73k2	57k6	46k4	39k2	33k2	28k7	24k9	[Ω]
Trim down	-1	-2	-3	-4	-5	-6	-7	-8	-9	-10	[%]
$V_{out_set} =$	11.88	11.76	11.64	11.52	11.4	11.28	11.16	11.04	10.92	10.8	[VDC]
R_{down} (E96) \approx	1M43	649k	412k	301k	237k	191k	162k	137k	118k	105k	[Ω]

RMD75-110-24SUW

Trim up	1	2	3	4	5	6	7	8	9	10	[%]
$V_{out_set} =$	24.24	24.48	24.72	24.96	25.2	25.44	25.68	25.92	26.16	26.4	[VDC]
R_{up} (E96) \approx	412k	187k	121k	86k6	68k1	54k9	45k3	39k2	34k	29k4	[Ω]
Trim down	-1	-2	-3	-4	-5	-6	-7	-8	-9	-10	[%]
$V_{out_set} =$	23.76	23.52	23.28	23.04	22.8	22.56	22.32	22.08	21.84	21.6	[VDC]
R_{down} (E96) \approx	2M74	1M43	976k	732k	576k	475k	402k	348k	301k	267k	[Ω]

RMD75-UW Series / Plug & Play Railway

75W / Ultra-Wide Input 16.8V-137.5VDC



REGULATIONS (measured @ $T_{AMB} = 25^{\circ}C$, nom. V_{IN} , full load and after warm-up unless otherwise stated)

Parameter	Conditions	Value
Output Accuracy		$\pm 3.0\%$ max.
Line Regulation	low line to high line, full load	$\pm 0.5\%$ max.
Load Regulation	0%-100% load	2.0% max.
Transient Response	10-90% load, $V_{IN} = 16.8-137VDC$	1.2VDC
	recovery time	5ms max.

PROTECTIONS (measured @ $T_{AMB} = 25^{\circ}C$, nom. V_{IN} , full load and after warm-up unless otherwise stated)

Parameter	Type	Value	
Internal Input Fuse		T20A, slow blow type	
Short Circuit Protection (SCP)		constant current mode, auto recovery	
Short Circuit Input Current	$V_{IN} = 24VDC$	3.4A	
	$V_{IN} = 110VDC$	0.7A	
Input Reverse Polarity Protection	active protected	-137.5VDC	
Over Voltage Protection (OVP)	clamping	120% - 140% of nom. V_{OUT}	
Over Voltage Category (OVC)	short term and continuous	OVC II	
Over Current Protection (OCP)	auto recovery	120% - 250% of rated I_{OUT}	
Class of Equipment		Class I	
Isolation Coordination	according to EN 50124-1:2018	$V_{NOM} = 250VDC$	
Isolation Voltage ⁽⁶⁾	1 minute	I/P to O/P	4.2kVDC
		I/P to case, OK contact to I/P, O/P and case	2.2kVDC
		O/P to case	1.5kVDC
Isolation Resistance		300M Ω min.	
Isolation Capacitance		1200pF typ.	
Insulation Grade		reinforced	
Internal Clearance	I/P to O/P	5mm	
	I/P to PE / O/P to PE	2.5mm	

Note6: For repeat Hi-Pot testing, reduce the time and/or the test voltage

POWER GOOD STANDARD VERSION

Parameter	Type	Value	
Power OK LED	RMD75-110-24SUW	$V_{OUT} > 21.6VDC$	green
		$V_{OUT} < 21.6VDC$	light off
Open Collector	RMD75-110-24SUW	$V_{OUT} > 21.6VDC$	OK= 5V/1mA
		$V_{OUT} < 21.6VDC$	NOK= 0V

POWER GOOD /PT VERSION

Parameter	Type	Value	
Power OK LED	RMD75-110-24SUW	$V_{OUT} > 21.6VDC$	green
		$V_{OUT} < 21.6VDC$	light off
Power Good		0.9Vout	
Changer Contact	RMD75-110-24SUW	$V_{OUT} > 21.6VDC$	OK: OK2 connected OK or OK1 not connected OK
		$V_{OUT} < 21.6VDC$	NOK: OK1 connected to OK or OK2 not connected OK

ENVIRONMENTAL (measured @ $T_{AMB} = 25^{\circ}\text{C}$, nom. V_{IN} , full load and after warm-up unless otherwise stated)

Parameter	Conditions		Value
Operating Ambient Temperature Range	without derating, normal operation		-40°C to +70°C
	according to EN 50155 class OT4 and extended operating temperature class ST1 & ST2	without derating for 15 minutes max.	-40°C to +85°C
Maximum Baseplate Temperature			+95°C
Temperature Coefficient			0.2%/K
Operating Altitude	according to EN 50124-1:2018		5000m
Operating Humidity	non-condensing		95% RH max.
Conformal Coating ⁽⁷⁾	according to EN 50155		Class PC2
Pollution Degree			PD2
IP Rating			IP20
Design Lifetime			20 years
MTBF	according to IEC 61709/ UTE C80-810	$T_{AMB} = +40^{\circ}\text{C}$	1950 x 10 ³ hours
		$T_{AMB} = +50^{\circ}\text{C}$	1400 x 10 ³ hours
Useful Life Class	according to EN50155:2018 (S1)		L4

Note7: The board is protected on both sides with a protective / transparent / fluorescent / coating. The coating is compliant with class 2, according to IPC-A-610G: 2017

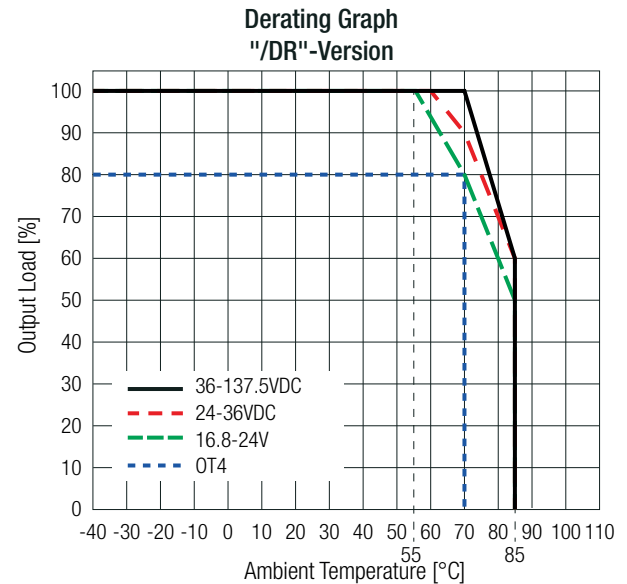
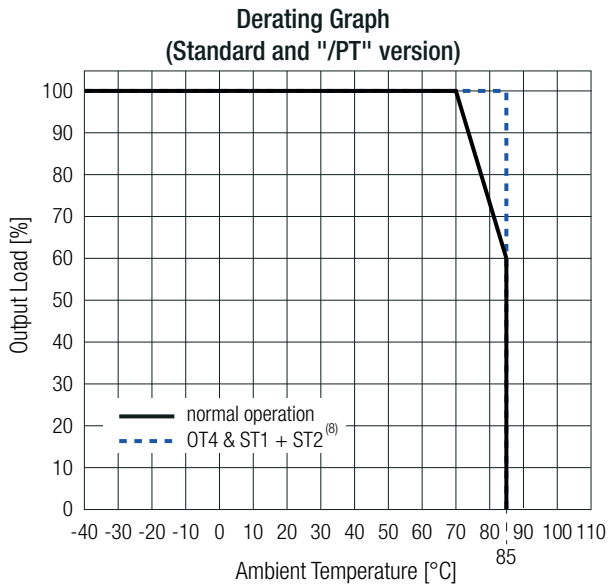

Note8: The specified operating temperature range -40°C to +85°C (covering OT4, ST1 and ST2) is valid only with conduction cooling to a thermally suitable baseplate (e.g. aluminum or equivalent) of at least 300 × 300 mm and 2.5mm thickness.

PEAK LOAD CAPABILITY

Peak power capability supports short power peaks of dynamic loads like motors, relays, storage devices or computer booting sequences. In addition allowing faster charge of load sided capacitors and reliable circuit breaker operation. The peak power rating applies only up to a maximum ambient temperature of +70°C. For Din-rail mounted version no peak power allowed, 75W max. continuous power!

- P_{nom} = nominal output power [W]
- P_p = peak output power (90W max) [W]
- P_r = recovery power ($\leq 60\text{W}$) [W]
- t_1 = peak time (10s max) [s]
- t_2 = recovery time ($3 \times t_1$) [s]

Calculation:

$$t_2 = \frac{(P_{nom} - P_p) \times t_1}{P_r - P_{nom}}$$

Practical Example:

- $P_{nom} = 75\text{W}$
- $P_p = 90\text{W}$
- $P_r = 60\text{W}$
- $t_1 = 10\text{s}$

$$t_2 = \frac{(75\text{W} - 90\text{W}) \times 30\text{s}}{60\text{W} - 75\text{W}} = \underline{\underline{30\text{s}}}$$

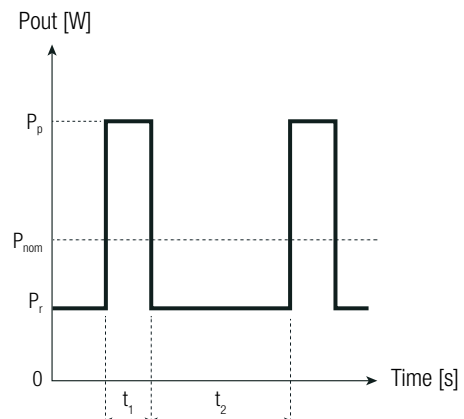

ENVIRONMENTAL (RAILWAY STANDARDS)

Parameter	Conditions	Value
Low Temperature start-up test	Temperature: -40°C; Stabilization time 2h	EN 60068-2-1 (Ad)
Dry heat test	Temperature: +70°C; Continuous operational checks time 6h	EN 60068-2-2 (Be) – Cycle A
Low temperature storage test	Temperature: -40°C; Low temperature exposition time 16h	EN 60068-2-1 (Ab)
Cyclic damp heat test	Temperature: +70°C/+25°C; Number of cycles: 2; Time 2x 24h	EN 60068-2-30 (Db)
Simulated long-life testing (Test performed at maximum level for each axis.)	Random Vibration, unit not powered during test Frequency range 5-150Hz with -6db/oct from 20 to 150Hz Vertical axis 5.72m/s ² for 5h [ASD 0.964(m/s ²) ² /Hz] Transverse axis 2.55m/s ² for 5h [ASD 0.192(m/s ²) ² /Hz] Longitudinal axis 3.96m/s ² for 5h [ASD 0.461(m/s ²) ² /Hz]	EN 61373 clause 9, class B Body mounted
Shock testing (Test performed at maximum level for each axis.)	Half-sine shock, unit powered during test; Vertical axis 30m/s ² for 30ms Transverse axis 30m/s ² for 30ms; Longitudinal axis 50m/s ² for 50ms Number of shocks: 18 (3x polarity for each axis)	EN 61373 clause 10, class B Body mounted
Functional random vibration test (Test performed at maximum level for each axis.)	Random Vibration, unit powered during test Frequency range 5-150Hz with -6db/oct from 20 to 150Hz Vertical axis 1.01m/s ² for 10min [ASD 0.0301(m/s ²) ² /Hz] Transverse axis 0.45m/s ² 10min [ASD 0.006(m/s ²) ² /Hz] Longitudinal axis 0.7m/s ² 10min [ASD 0.0144(m/s ²) ² /Hz]	EN 61373 clause 8, class B Body mounted
Railway applications - Fire protection on railway vehicles - Part 2: Requirements for fire behavior of materials and components	R24 & R25	EN45545-2 Hazard Level HL1 - HL3

SAFETY & CERTIFICATIONS

Certificate Type (Safety)	Report Number	Standard
Audio/video, information and communication technology equipment. Safety requirements	80235804-00	IEC62368-1:2018 3rd Edition EN IEC 62368-1:2020+A11:2020
Railway applications - Insulation coordination - Part 1: Basic requirements - Clearances and creepage distances for all electrical and electronic equipment	RMD40&RMD75_V1.0	EN50124-1
Railway Applications - Electrical Equipment used on rolling stock		EN50155
RoHS2		RoHS 2011/65/EU + AM2015/863

EMC Compliance	Conditions	Standard / Criterion
Railway applications - Electromagnetic compatibility		EN50121-3-2:2016
Electromagnetic compatibility (EMC) - Part 6-2: Generic standards - Immunity standard for industrial environments		EN IEC 61000-6-2:2019
Electromagnetic compatibility (EMC) - Part 6-4: Generic standards - Emission standard for industrial environments	V _N = 24VDC & 110VDC	EN61000-6-4:2007+A1:2011
ESD Electrostatic discharge immunity test	V _N = 24VDC & 110VDC Air: ±2, 4, 8kV Contact: ±2, 4, 8kV	IEC61000-4-2:2008, Criteria A EN61000-4-2:2009, Criteria A
Radiated, radio-frequency, electromagnetic field immunity test	V _N = 24VDC & 110VDC 20V/m (80-1000MHz) 10V/m (1000-6000MHz)	IEC/EN61000-4-3:2010, Criteria A
Fast Transient and Burst Immunity	DC Power Port: ±2kV DC Output Port: ±2kV	IEC/EN61000-4-4:2012, Criteria A
Surge Immunity	V _N = 24VDC & 110VDC DC Power Port sym.: ±0.5, 1kV DC Power Port unsym.: ±0.5, 1, 2kV	IEC/EN61000-4-5:2014, Criteria A
Immunity to conducted disturbances, induced by radio-frequency fields	V _N = 24VDC & 110VDC DC Power Port: 10Vr.m.s. (0.15-80MHz)	IEC61000-4-6: 2013, Criteria A EN61000-4-6:2014, Criteria A
Power Magnetic Field Immunity	V _N = 24VDC & 110VDC 30A/m, 50/60Hz	IEC61000-4-8:2009, Criteria A EN61000-4-8:2010, Criteria A
Railway applications - Electromagnetic compatibility	V _N = 24VDC & 110VDC	EN50121-3-2:2016+A1:2019
Technische Regeln zur Elektromagnetischen Verträglichkeit: Nachweis der Funkverträglichkeit von Schienenfahrzeugen mit Bahnfunkdiensten	V _N = 24VDC & 110VDC	Regelung Nr. EMV 06:2019

DIMENSION & PHYSICAL CHARACTERISTICS

Dimension Drawing "/PT" Version (mm)

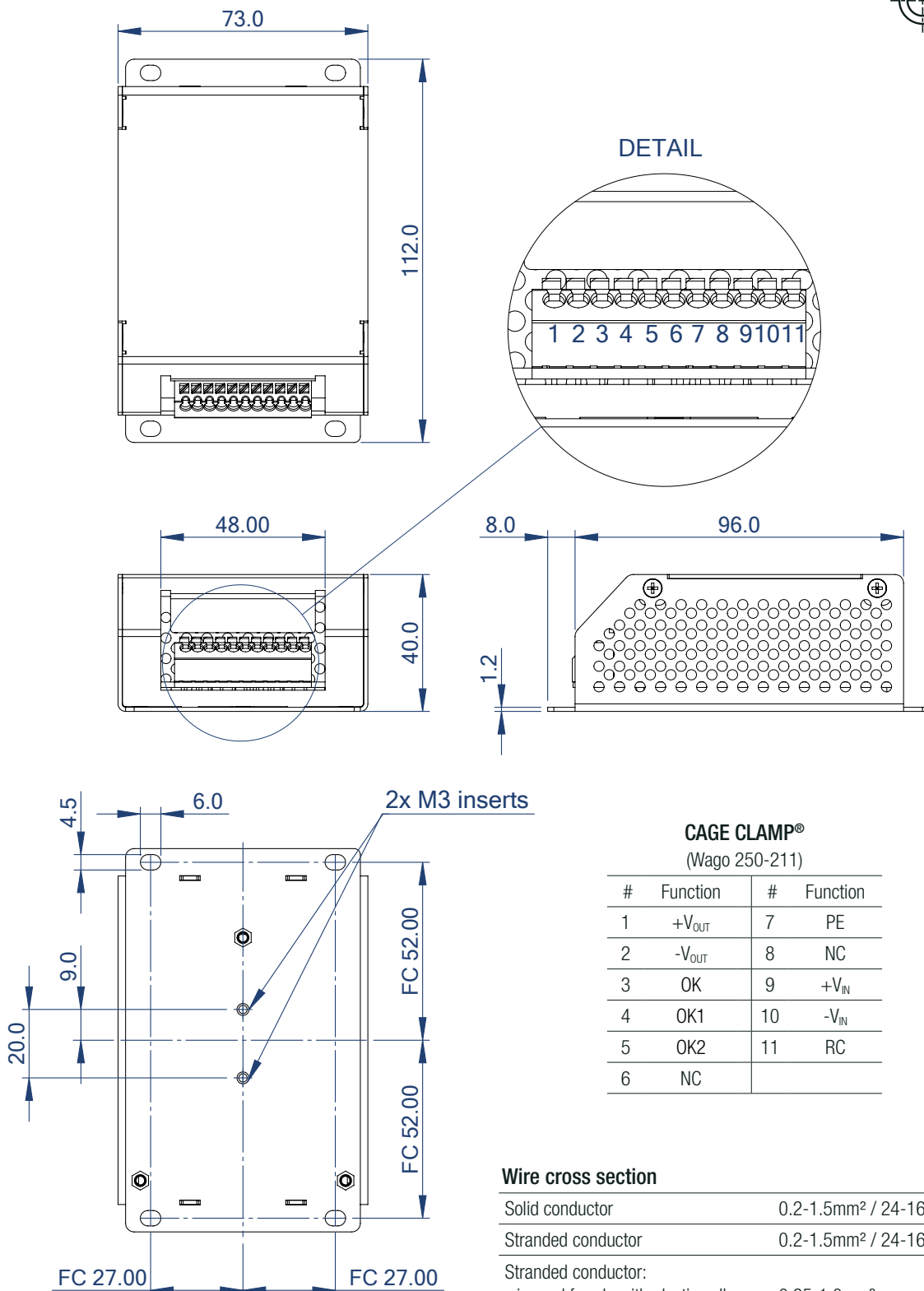
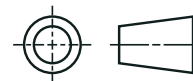

Note10: The M3 inserts can be used for DIN-rail clip (max. penetration= 2.5mm)

Tolerances:
 xx.x= ±0.5mm
 xx.xx= ±0.25mm
 FC = fixing centers

DIMENSION & PHYSICAL CHARACTERISTICS

Dimension Drawing "/DR" Version (mm)

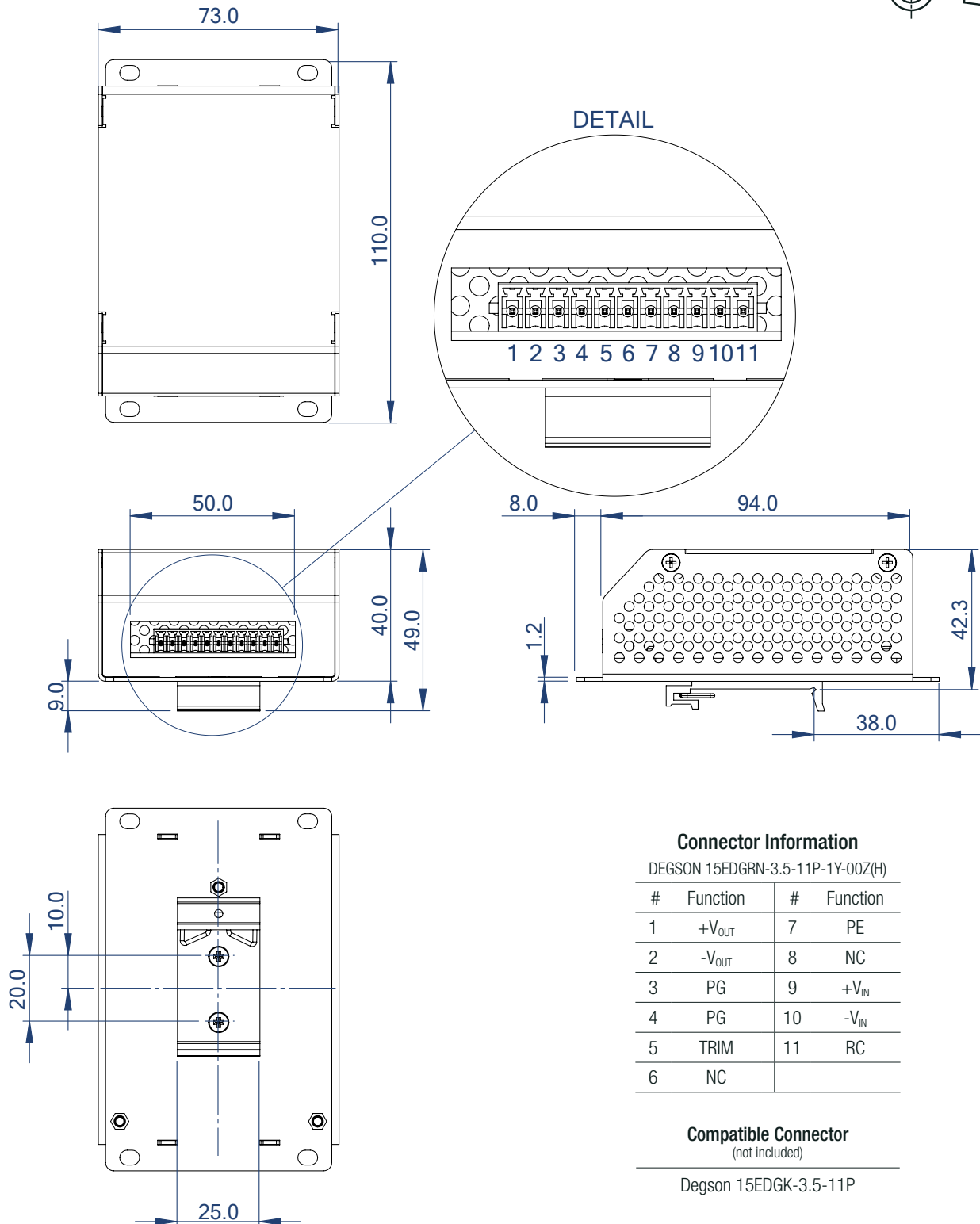
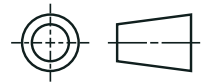

Tolerances:
 xx.x= ±0.5mm
 xx.xx= ±0.25mm
 FC = fixing centers

DIMENSION & PHYSICAL CHARACTERISTICS

Dimension Drawing "/PT/DR" Version (mm)

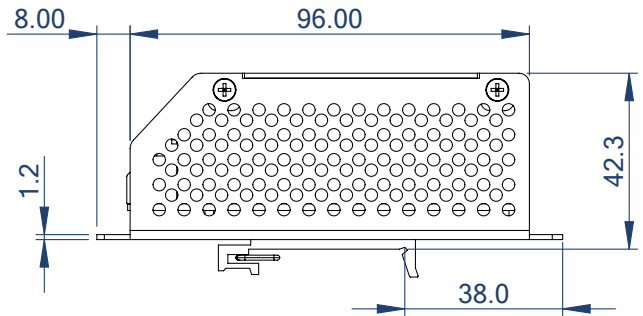
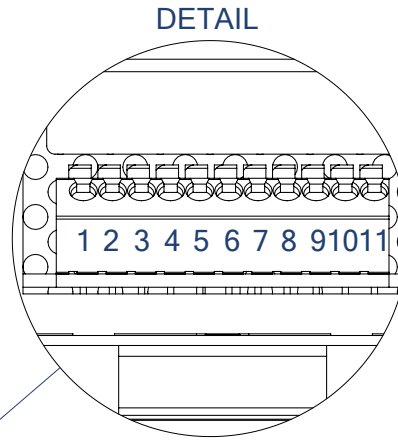
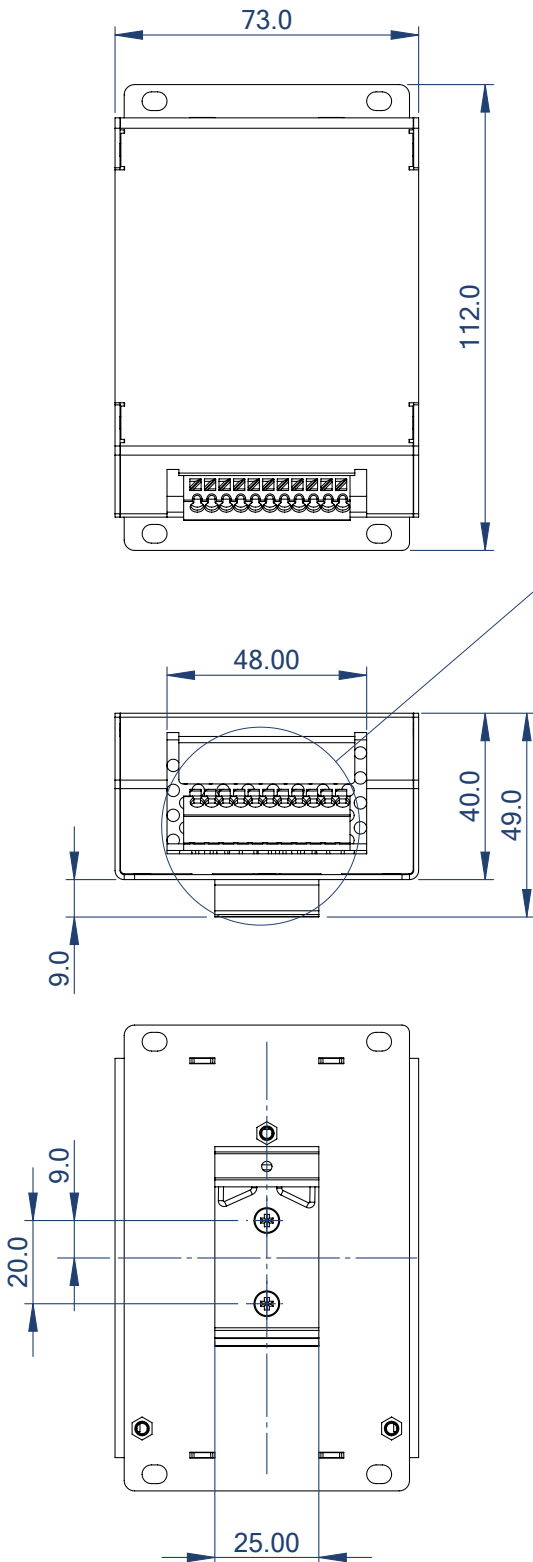
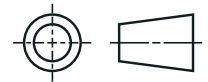

CAGE CLAMP®
(Wago 250-211)

#	Function	#	Function
1	+V _{OUT}	7	PE
2	-V _{OUT}	8	NC
3	OK	9	+V _{IN}
4	OK1	10	-V _{IN}
5	OK2	11	RC
6	NC		

Wire cross section

Solid conductor	0.2-1.5mm ² / 24-16 AWG
Stranded conductor	0.2-1.5mm ² / 24-16 AWG
Stranded conductor:	
wire end ferrule with plastic collar	0.25-1.0mm ²
wire end ferrule without plastic collar	0.25-1.0mm ²
Stripping length	8.5-9.5mm / 0.33-0.37 inch

Tolerances:
 xx.x= ±0.5mm
 xx.xx= ±0.25mm
 FC = fixing centers

INSTALLATION & APPLICATION

Mounting Instructions Standard Version

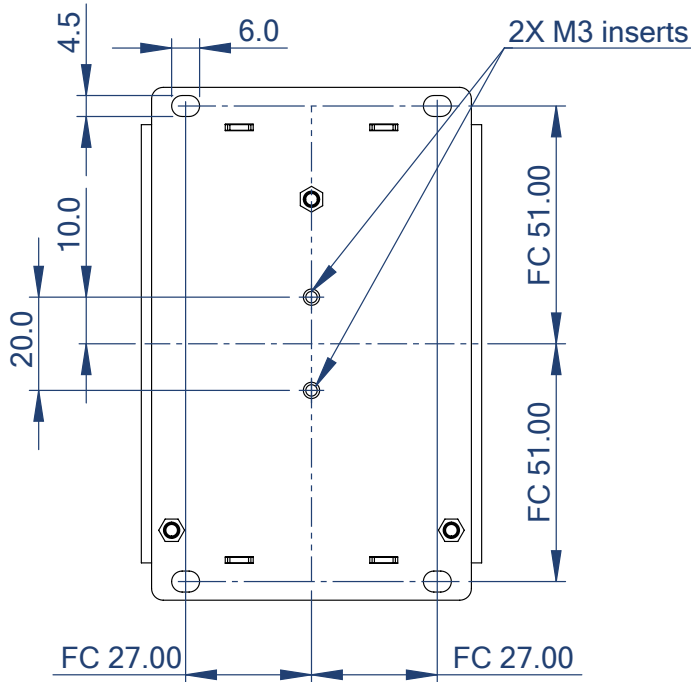

Mounting Instructions /PT Version

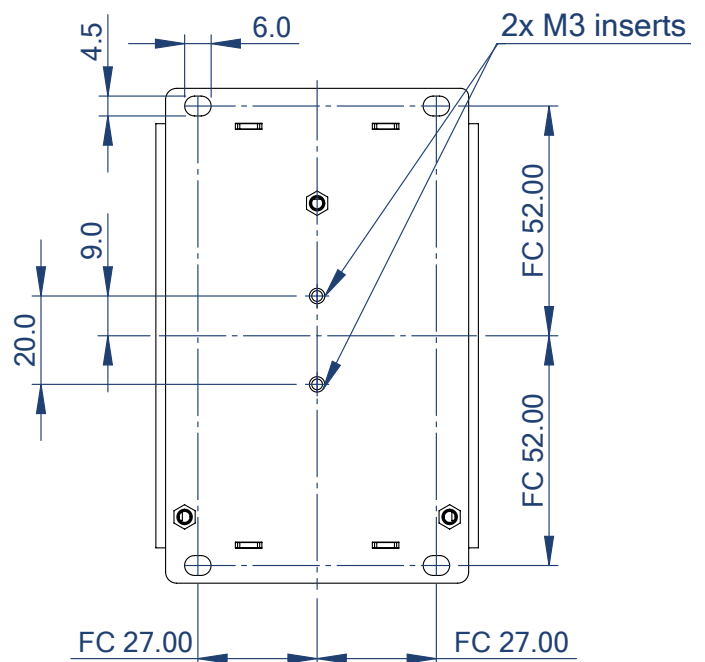

Natural air convection around the unit must be possible at any time and the temperature shall not be exceeded.

The RMD converter has to be installed with 4 x M4 screws and can be mounted in any mounting direction.

All control and signal terminals have been tested and have passed the requirements according to the EN50121-3-2 regulations, nevertheless for installation conditions with cable lengths above 30m, maybe additional protection against disturbances will be necessary.

Mounting Instructions "/DR"-Versions

Mounting Rail: Standard TS35 DIN Rail in accordance with EN 60715.

Mounting

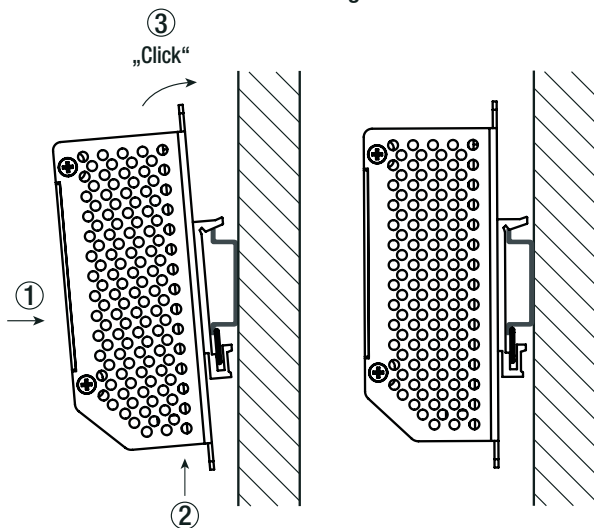

Release

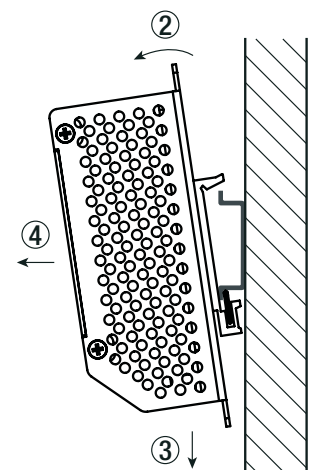

1. Tilt the device slightly forward.
2. Place the device on the rail and slide it upward until it reaches the stop.
3. Press the device toward the rail at the top until you hear a "click." The device is now locked in place.
4. To ensure that it is secure, shake the device gently.

1. Push the device upwards.
2. While pushing the device upwards, tilt the top of the device away from the DIN rail.
3. Pull the device downward from the DIN rail.
4. Remove the device completely from the DIN rail.

INSTALLATION & APPLICATION

Installation Guidelines DR-Version

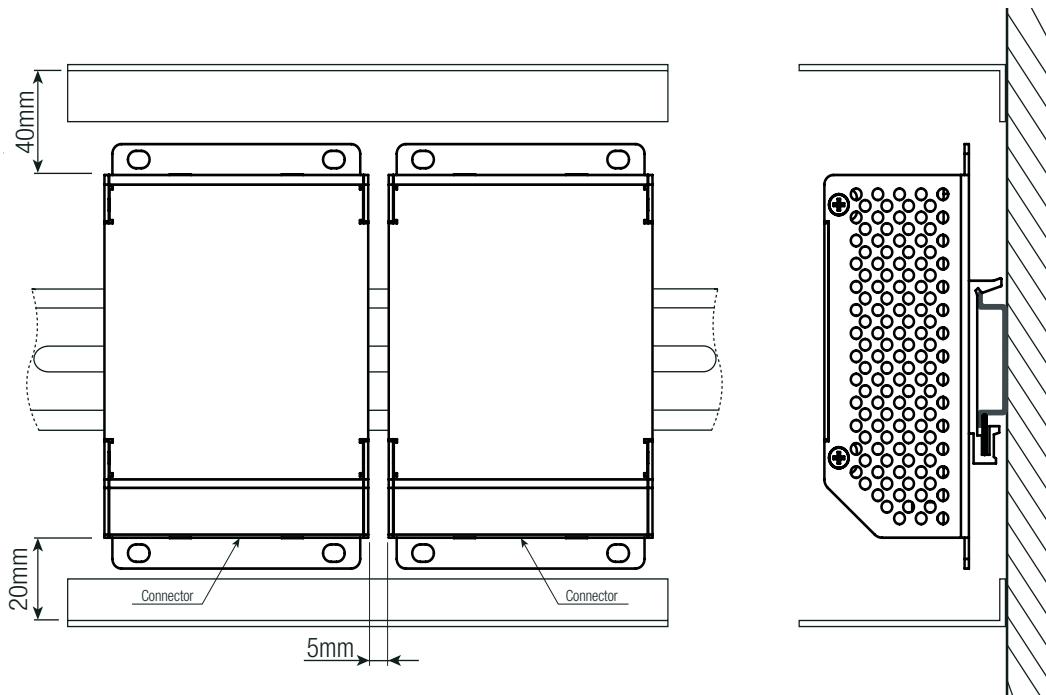

Note10: To guarantee sufficient convection cooling, keep a distance of 40mm above and 20mm below the device as well as a gap of 5mm between 2 units.

Parallel Operation

- 1) Adjust each unit to the exact same output voltage with same load and cooling conditions. (More than 3 units connected in parallel are not recommended)
- 2) Use the same wire length and cable cross-section for each unit (star connection) and energize all units at the same time to avoid triggering overload protection.
- 3) A 10% safety margin may be recommended because the power distribution may be slightly asymmetrical depending on the cabling.
- 4) **ATTENTION:**

To prevent high reverse currents in the event of a secondary output fault, it is recommended to install a protective circuit at the output of each device when more than two units are connected in parallel (e.g. decoupling diode or DC fuse).

Leakage current, EMI, inrush current, harmonics will increase when using multiple power supplies.

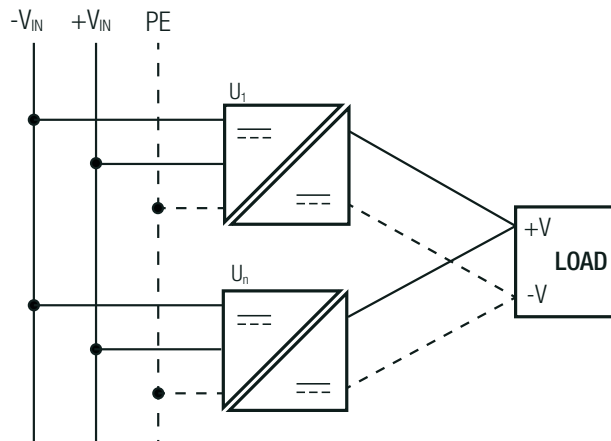

BLOCK DIAGRAM

Standard Version

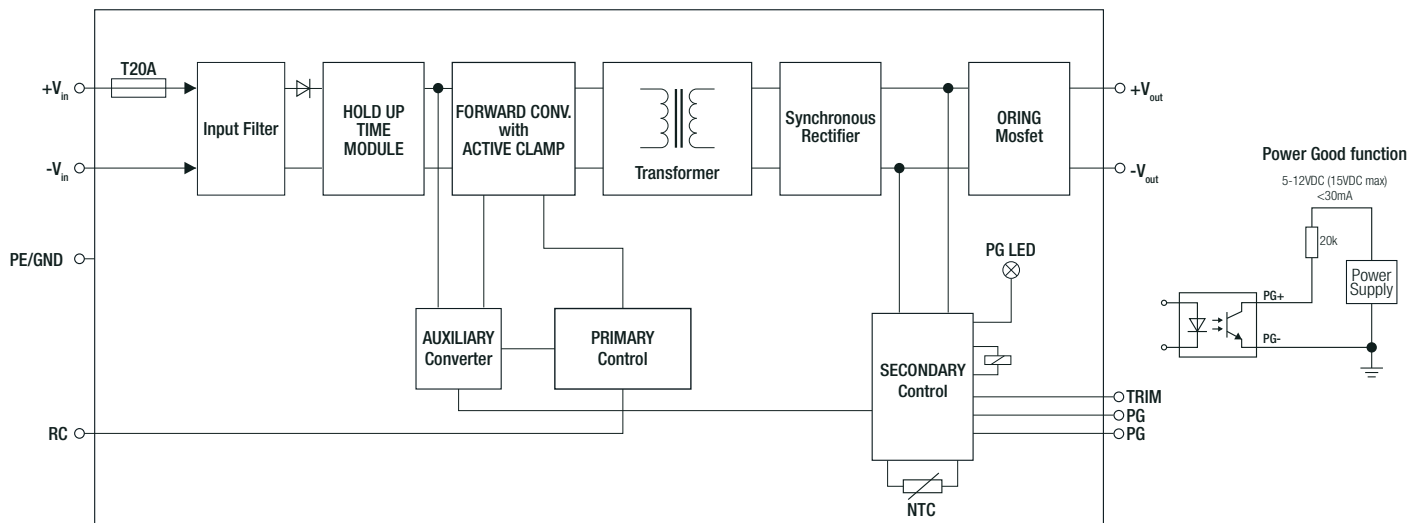

/PT Version

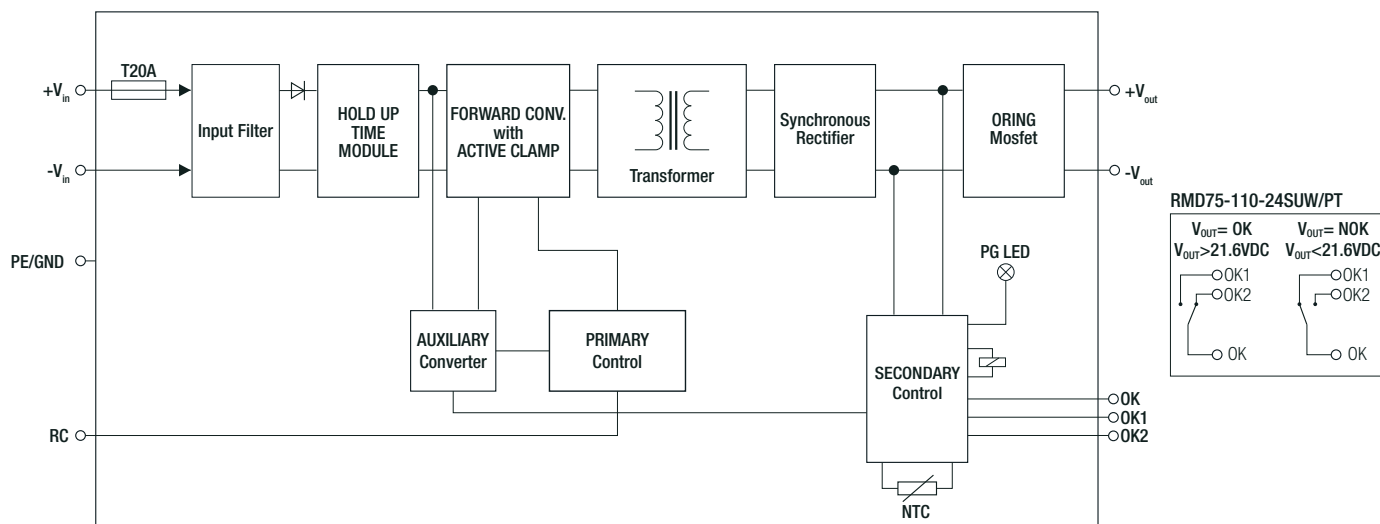

PACKAGING INFORMATION

Parameter	Type	Value
Packaging Dimension (LxWxH)	cardboard box	340.0 x 255.0 x 110.0mm
Packaging Quantity		10pcs
Storage Temperature Range		-55°C to +85°C
Storage Humidity	non-condensing	85% RH max.

The product information and specifications may be subject to changes even without prior written notice. The product has been designed for various applications; its suitability lies in the responsibility of each customer. The products are not authorized for use in safety-critical applications without RECOM's explicit written consent. A safety-critical application is an application where a failure may reasonably be expected to endanger or cause loss of life, inflict bodily harm or damage property. The applicant shall indemnify and hold harmless RECOM, its affiliated companies and its representatives against any damage claims in connection with the unauthorized use of RECOM products in such safety-critical applications.

 www.simpex.ch

Besuchen Sie unseren Simpex E-Shop mit über 12'000 Produkten.

Er bietet Ihnen eine breite Funktionsvielfalt, sowie intelligente Suchfunktionen. Ob Sie den Shop als Einkaufsplattform oder als Produktfinder nutzen – im Simpex E-Shop haben Sie alle Informationen schnell und tagesaktuell zur Hand.

24h und das 365 Tage im Jahr.



Hauptsitz

Simpex Electronic AG
Binzackerstrasse 33
CH-8620 Wetzikon
Telefon +41 44 931 10 10
E-Mail contact@simpex.ch
Internet www.simpex.ch

Manufaktur

Simpex Electronic SA
En Bas-le-Port 1
CH-2088 Cressier
E-Mail contact@simpex.ch
Internet www.simpex.ch