

■ Features

- Combining AC → DC and DC → AC bidirection power, **5KW full-power** operation in both directions
- Ultra-fast bidirectional time of **1ms**(AC ⇌ DC)
- **Global certificates in multi-fields** (ITE 62368-1, Energy converter 62477-1, AC Grid system 50549-1)
- 180~305Vac(277Vac available)
- High efficiency up to 93.5%
- THD <3% in both conversion mode
- **Parallel** operation up to **30KW(5+1 unit)**
- Support CANBus or MODBus-RTU(RS-485) protocol communication
- Complete protections: Anti-islanding protection, AC fail protection, DC OVP, OLP, OCP, OTP
- Over voltage category III (**OVC III**)
- -30°C~+70°C wide operating temperature
- FAN noise < 43~54dB
- **Support 3Ø** with multiple units configuration
- **Conformal coating**
- **5 years warranty**

■ Applications

- Battery cell formation & grading
- V2G (Vehicle-to-grid) system
- Marine battery charger module
- Electric scooter or vehicle charger station
- Kinetic energy recovery system
- Electrolysis system
- Wastewater treatment system

■ GTIN CODE

MW Search: <https://www.meanwell.com/serviceGTIN.aspx>

■ Description

The BIC-5K series is a 5KW bidirectional power supply featuring AC-DC ⇌ DC-AC conversion with energy recovery functionality. This product adopts a fully digitalized design, characterized by high efficiency, intelligence, compact size, and comprehensive safety certifications. It is commonly used in applications such as battery factory grading/forming testing equipment, home energy storage systems, kinetic energy recovery systems, and distributed grids (V2G). The BIC-5K series is a high-reliability green energy power solution that supports energy saving and carbon reduction.

■ Model Encoding

BIC - 5K - 24

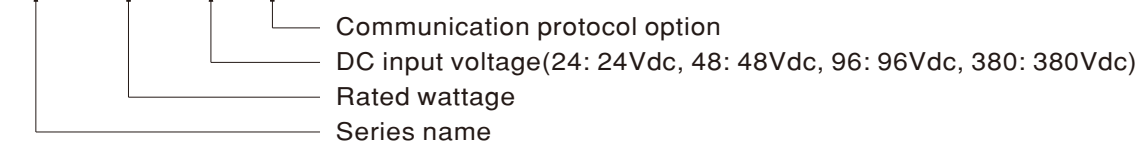

Type	Communication Protocol	Note
Blank	CANBus protocol	In Stock
MOD	MODBus protocol	In Stock



SPECIFICATION		BIC-5K-24 <input type="checkbox"/>	BIC-5K-48 <input type="checkbox"/>	BIC-5K-96 <input type="checkbox"/>	BIC-5K-380 <input type="checkbox"/>
		<input type="checkbox"/> =Blank, MOD (standard model in stock)			
AC to DC Direction	OUTPUT				
	DC VOLTAGE	24V	48V	96V	380V
	RATED CURRENT	208A	104A	52A	15A
	RATED POWER	4992W	4992W	4992W	5025W
	FULL POWER VOLTAGE RANGE	24 ~ 33V	48 ~ 66V	96 ~ 112V	335 ~ 430V
	RIPPLE & NOISE (max.) Note.2	350mVp-p	600mVp-p	900mVp-p	2.8Vp-p
	VOLTAGE RANGE	19 ~ 33V	38 ~ 66V	76 ~ 112V	280 ~ 430V
	CURRENT RANGE	0 ~ 208A	0 ~ 104A	0 ~ 52A	0 ~ 15A
	VOLTAGE TOLERANCE Note.3	±2.0%			
	LINE REGULATION	±1.0%			
	LOAD REGULATION	±1.0%			
	SETUP, RISE TIME	8000ms, 150ms/230Vac at full load			
	INPUT				
	AC VOLTAGE RANGE	180 ~ 305Vac			
	FREQUENCY RANGE	47 ~ 63Hz			
	POWER FACTOR (Typ.)	≥ 0.99/230Vac at full load			
EFFICIENCY (Typ.) Note.4	91%	93%	93%	93%	
AC CURRENT (Typ.)	27A/230Vac				
INRUSH CURRENT (Typ.)	120A/230Vac				
LEAKAGE CURRENT (Peak)	7.07mA/305Vac				
TOTAL HARMONIC DISTORTION	<3%(@load=100%/230Vac)				
DC to AC Direction	INPUT				
	INPUT POWER (Max.)	5665W	5550W	5550W	5500W
	FULL POWER VOLTAGE RANGE	24 ~ 33V	48 ~ 66V	96 ~ 112V	335 ~ 430V
	DC VOLTAGE RANGE	19 ~ 33V	38 ~ 66V	76 ~ 112V	280 ~ 430V
	MAX. INPUT CURRENT	232A	114A	57A	16A
	OUTPUT				
	RATED OUTPUT POWER (Typ.)	5000W			
	VOLTAGE RANGE	180 ~ 305Vac determined by AC main (277Vac available)			
	FREQUENCY RANGE	47 ~ 63Hz determined by AC main			
	AC CURRENT (Typ.)	22.5A/230Vac			
	POWER FACTOR (Typ.)	0.99/230Vac at full load			
	EFFICIENCY (Typ.) Note.4	91%	93.5%	93%	93.5%
TOTAL HARMONIC DISTORTION	<3%(@load=100%/230Vac)				
PROTECTION					
OVER LOAD	105 ~ 115% rated output power				
	AC to DC	Constant current limiting, shut down DC O/P voltage 5 sec. after DC O/P voltage is down low, re-power on to recover			
	DC to AC	Not accurable with constant power design			
SHORT CIRCUIT	Shut down O/P current, re-power on to recover				
OVER VOLTAGE	34 ~ 35V	68 ~ 70V	115 ~ 121V	435 ~ 450V	
	Protection type : Shut down O/P voltage, re-power on to recover				
OVER TEMPERATURE	Shut down O/P voltage, recovers automatically after temperature goes down				
ISLANDING PROTECTION	Shut down AC O/P voltage, re-power on to recover				
FUNCTION					
BIDIRECTION SWITCH TIME (Typ.)	1ms	1ms	3ms	1ms	
PARALLEL	Up to 30KW(5+1) units, Please refer to the Function Manual				
CANBUS or MODBUS	Communication provides function such as control, setting and monitoring				
REMOTE ON-OFF CONTROL	By electrical signal or dry contact Short: Power ON Open: Power OFF Please refer to the Function Manual infollowing				
FAN SPEED CONTROL (Typ.)	Note.6	Built-in intelligent fan speed control detect by PSU's internal temperature			
	10% load with Ta=25°C	54dB	43dB	43dB	
	70% load with Ta=25°C	54dB	44dB	44dB	



ENVIRONMENT			
WORKING TEMP.	-30 ~ +70°C (Refer to "Derating Curve")		
WORKING HUMIDITY	20 ~ 90% RH non-condensing		
STORAGE TEMP., HUMIDITY	-40 ~ +85°C, 10 ~ 95% RH non-condensing		
TEMP. COEFFICIENT	±0.03%/°C (0 ~ 40°C)		
VIBRATION	10 ~ 500Hz, 3G 10min./1cycle, 60min. each along X, Y, Z axes		
SAFETY & EMC			
SAFETY STANDARDS	CB IEC62368-1/IEC62477-1, IEC50549-1, UL62368-1, CAN/CSA C22.2 No.62368-1,TUV BS EN/EN62368-1, BS EN/EN50549-1, EAC TP TC 004 approved		
OVER VOLTAGE CATEGORY	IEC/EN/UL 62368-1 (OVC III, altitude up to 2000m) IEC/EN 62477-1 (OVC III, altitude up to 2000m)		
WITHSTAND VOLTAGE	Note.7	I/P-O/P:6KVdc I/P-FG:4KVdc O/P-FG:4KVdc	
ISOLATION RESISTANCE	Note.7	I/P-O/P, I/P-FG, O/P-FG:100M Ohms / 500Vdc / 25°C / 70% RH	
EMC EMISSION	BS EN/EN55032		
	Parameter	Standard	Test Level / Note
	Conducted	BS EN/EN55032 (CISPR32)	Class A
	Radiated	BS EN/EN55032 (CISPR32)	Class A
	Harmonic Current	BS EN/EN61000-3-12	Class A
	Voltage Flicker	BS EN/EN61000-3-3	-----
EMC IMMUNITY	BS EN/EN55035, BS EN/EN61000-6-2		
	Parameter	Standard	Test Level / Note
	ESD	BS EN/EN61000-4-2	Level 3, 8KV air ; Level 2, 4KV contact
	Radiated	BS EN/EN61000-4-3	Level 3
	EFT / Burst	BS EN/EN61000-4-4	Level 3
	Surge	BS EN/EN61000-6-2	2KV/Line-Line 4KV/Line-Earth
	Conducted	BS EN/EN61000-4-6	Level 3
	Magnetic Field	BS EN/EN61000-4-8	Level 4
	Voltage Dips and Interruptions	BS EN/EN61000-4-11	>95% dip 0.5 periods, 30% dip 25 periods, >95% interruptions 250 periods
OTHERS			
MTBF	209.4K hrs min. Telcordia SR-332 (Bellcore) ; 17.8K hrs min. MIL-HDBK-217F (25°C)		
DIMENSION	460*211*83.5mm (L*W*H)		
PACKING	12Kg; 1pcs/ 12Kg/ 1.25CUFT		
NOTE			
<ol style="list-style-type: none"> All parameters NOT specially mentioned are measured at 230VAC input, rated load and 25°C of ambient temperature. Ripple & noise are measured at 20MHz of bandwidth by using a 12" twisted pair-wire terminated with a 0.1uf & 47uf parallel capacitor. Tolerance : includes set up tolerance, line regulation and load regulation. Efficiency is tested 75% load, linear load at 230Vac input voltage and 24V/48V/96V/380Vdc output voltage The power supply is considered as an independent unit, but the final equipment still need to re-confirm that the whole system complies with the EMC directives. FAN noise test set up according to ISO-7779. During withstand voltage and isolation resistance testing, the screw "A" shall be temporarily removed, and shall be installed back after the testing. 			
※ Product Liability Disclaimer : For detailed information, please refer to https://www.meanwell.com/serviceDisclaimer.aspx			

■ BLOCK DIAGRAM

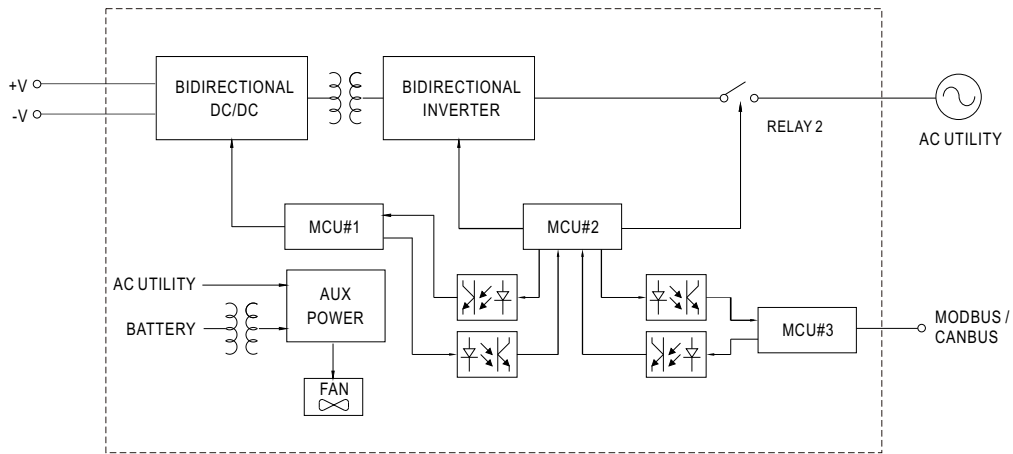

■ DERATING CURVE

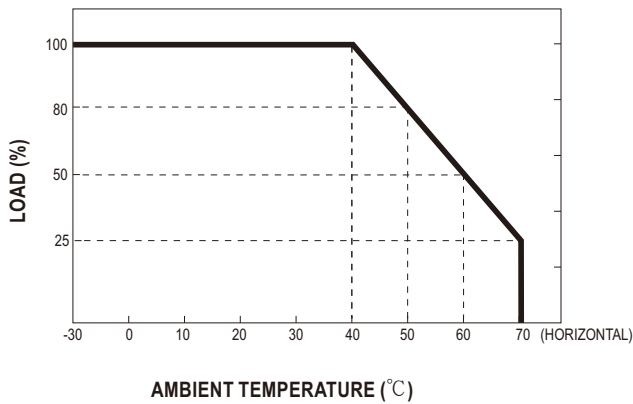

■ STATIC CHARACTERISTICS

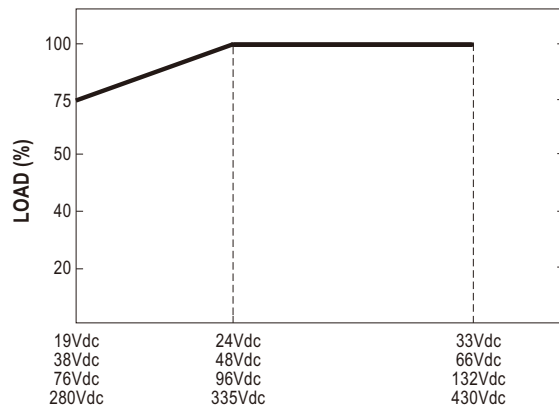

■ STATIC CHARACTERISTICS

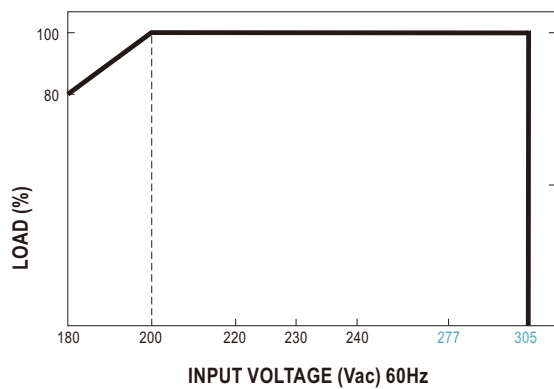

1. Bidirection process

BIC-5K possesses AC to DC and DC to AC two way conversion functions. The conversion direction can be automatically detected and controlled by BIC-5K's internal firmware or manually switched by users according to different application requirements. Before entering detailed function explanation. Please refer to following definitions.

AC to DC (Energy absorbing and charging/ power supplying):

The BIC-5K converts AC energy from the grid into DC energy for the battery or the loads. The operation principle is the same as an ordinary power supply or a charger.

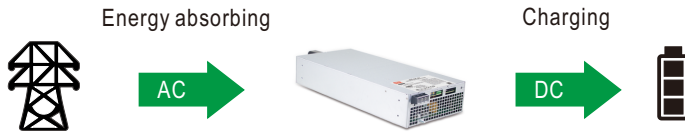

DC to AC (Energy recycling and discharging):

Opposite to the AC to DC conversion, the BIC-5K converts DC energy from the battery or loads into AC energy, then feeding back to the grid. AC output synchronization range is 180Vac~305Vac/47Hz~63Hz, the bidirectional power supply can work normally as long as the AC grid is within the range.

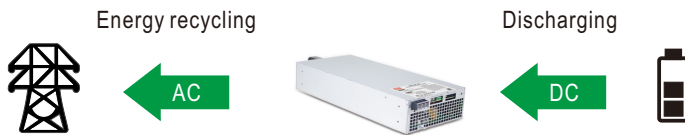

Bi-direction auto-detect mode:

This is default factory setting, BIC-5K operates as table below

Condition	Mode
Set voltage > load voltage	AC to DC
Set voltage < load voltage	DC to AC

Bi-direction battery mode:

This mode only can be activated. Set the BIC-5K in AC to DC (charging) or DC to AC (discharging) conversion directly through command DIRECTION_CTRL below.

Command	Conversion
DIRECTION_CTRL = 00h	AC to DC (charging)
DIRECTION_CTRL = 01h	DC to AC (discharging)

2. Support CANBus / MODBus Communication

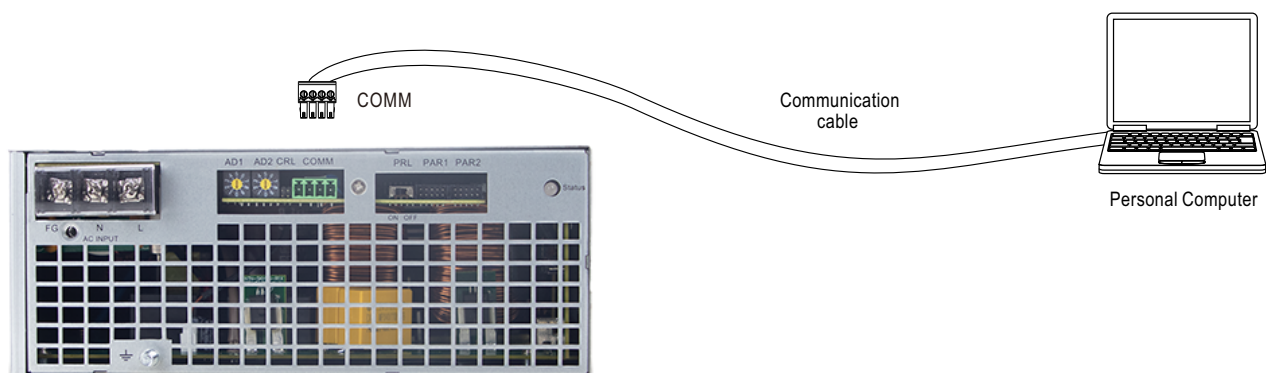

※ Please refer to the user manual for detailed instructions.

3. Current Sharing

BIC-5K has the built-in active current sharing function and can be connected in parallel, up to 6 units, to provide higher output power as exhibited below :

- ※ The power supplies should be paralleled using short and large diameter wiring and then connected to the load.
- ※ In parallel connection, power supply with the highest output Voltage will be the master unit and its Vout will be the DC bus voltage.
- ※ The total output current must not exceed the value determined by the following equation:

$$\text{Maximum output current at parallel operation} = (\text{Rated current per unit}) \times (\text{Number of unit}) \times 0.95$$
- ※ When the total output current is less than 5% of the total rated current, or say $(5\% \text{ of Rated current per unit}) \times (\text{Number of unit})$ the current shared among units may not be balanced.
- ※ PAR1/PAR2, PRL Function pin connection

Parallel	PSU1		PSU2		PSU3		PSU4		PSU5		PSU6	
	PAR1	PRL	PAR1	PRL	PAR1	PRL	PAR1	PRL	PAR1	PRL	PAR1	PRL
1 unit	X	ON	—	—	—	—	—	—	—	—	—	—
2 unit	✓	ON	✓	ON	—	—	—	—	—	—	—	—
3 unit	✓	ON	✓	OFF	✓	ON	—	—	—	—	—	—
4 unit	✓	ON	✓	OFF	✓	OFF	✓	ON	—	—	—	—
5 unit	✓	ON	✓	OFF	✓	OFF	✓	OFF	✓	ON	—	—
6 unit	✓	ON	✓	OFF	✓	OFF	✓	OFF	✓	OFF	✓	ON

(✓ : PAR1 connected ; X : PAR1 not connected)

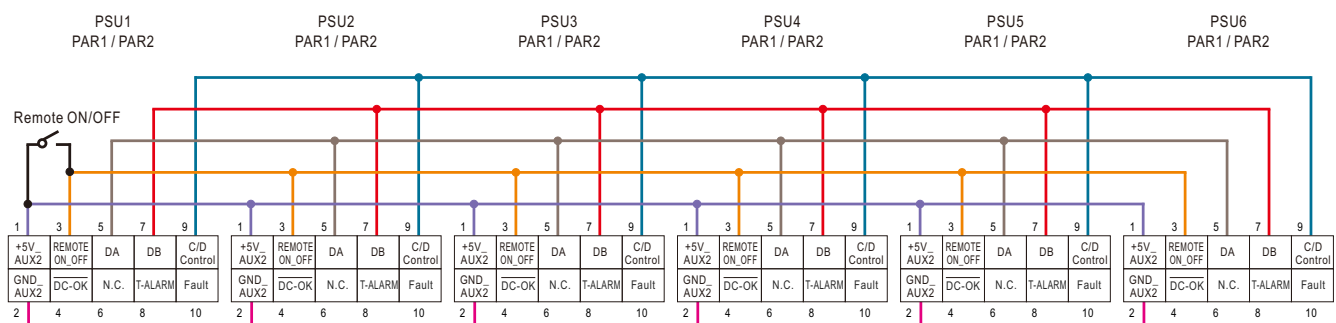
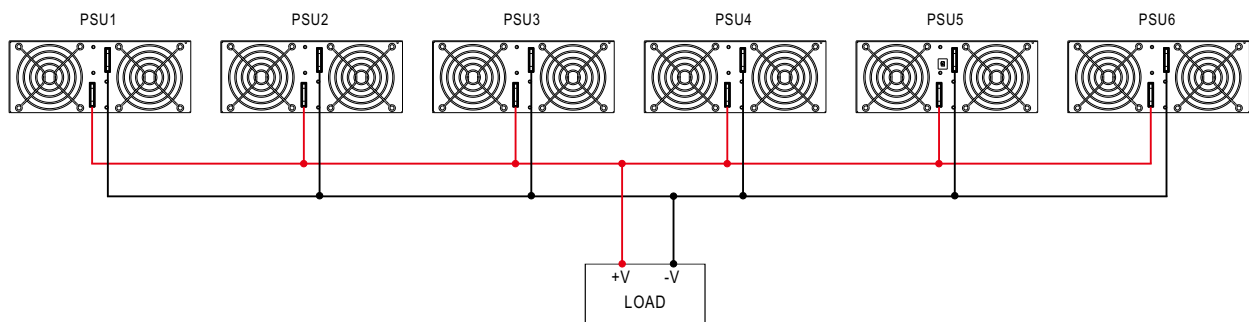

↑
If the lines of PAR1 / PAR2 are too long, they should be twisted in pairs to avoid the noise.

4.3Ø 4W/Y

The BIC-5K can be installed in a 3-phase 4-wire AC power system. To ensure more balanced operation of multiple BIC-5K units within the system, it is recommended to evenly distribute the bidirectional power supplies across each phase. For example, if 6 units need to be installed, they should be split into 2 for each phase.

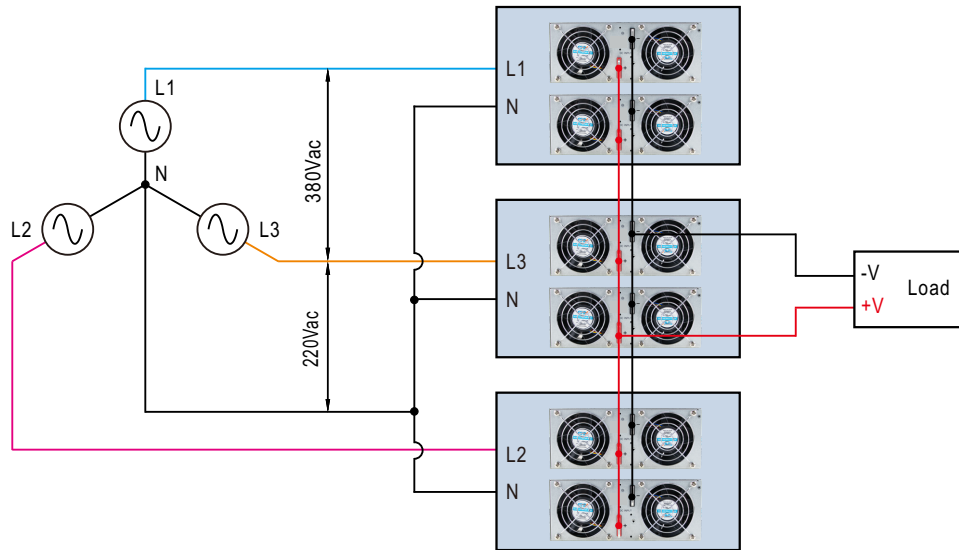

5. Remote ON-OFF Control

PAR1/PAR2	Remote ON-OFF	AC Output Status
Pin1:3	Short	Power inverter ON
Pin1:3	Open	Power inverter OFF

MECHANICAL SPECIFICATION

(Unit: mm, tolerance ±0.5mm)

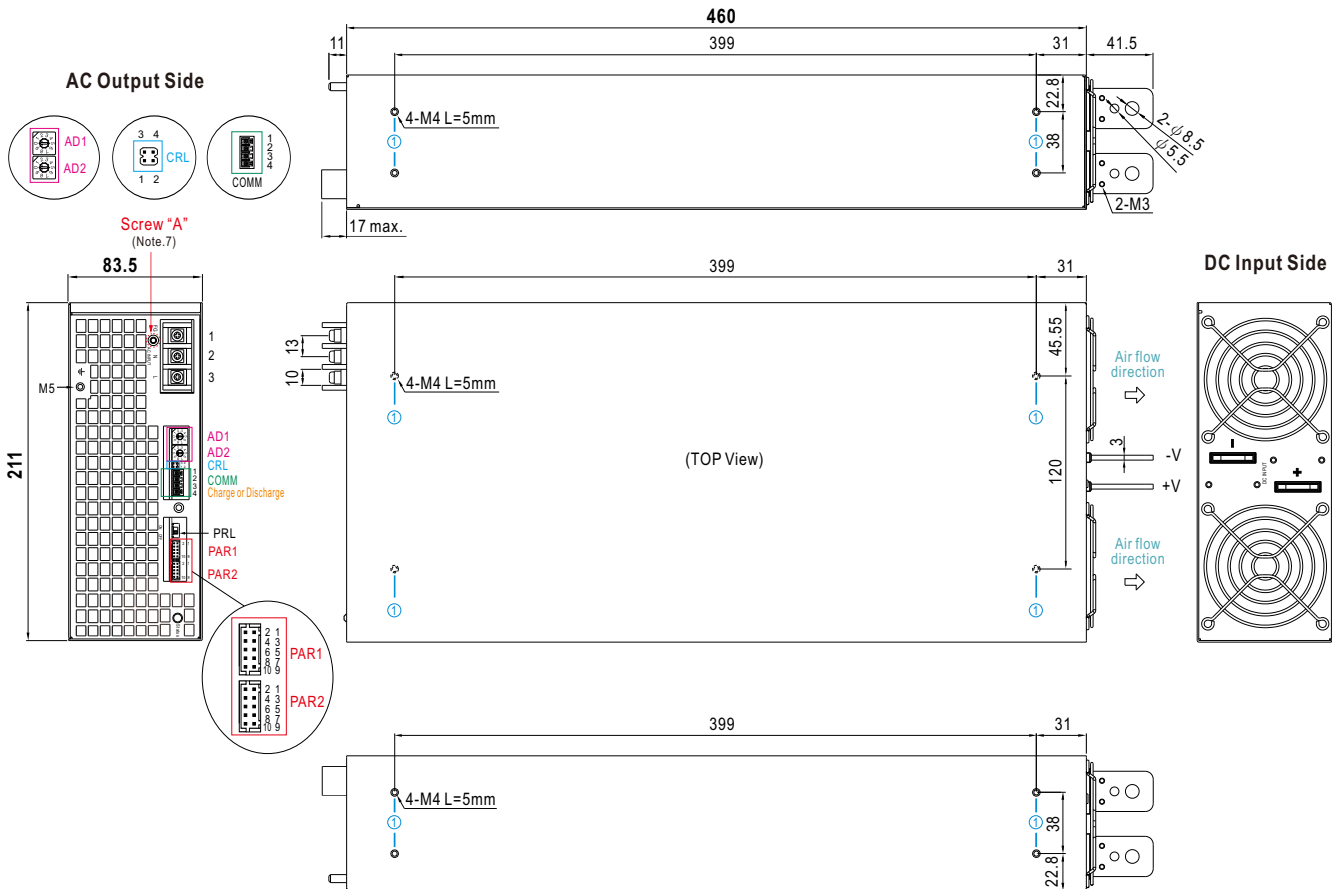

※ Mounting Instruction

Hole No.	Recommended Screw Size	MAX. Penetration Depth L	Recommended mounting torque
①	M4	5mm	7~10Kgf-cm

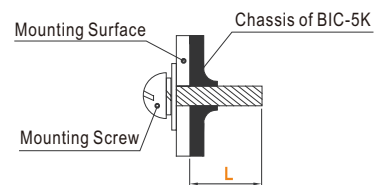





※ Terminal Pin No. Assignment

Pin No.	Assignment	Terminal	Maximum mounting torque
1	FG		18Kgf-cm
2	AC/N		
3	AC/L		

※ LED Status Indicators





1. BIC mode

LED	Description
 Green	AC to DC Direction, functions as regular power supply.
 Green	DC to AC Direction, functions as grid inverter.
 Red	Abnormal status (Over temperature protection, Overload protection, Fan fail.)
 Orange	Standby during startup

 Light

 Flash













2. Grid mode& charger mode

LED	Description
 Green	Grid mode: Negative power : Charger mode:Float or Battery full.
 Green	DC to AC Direction, functions as grid inverter.
 Red	Abnormal status (Over temperature protection, Overload protection, Fan fail.)
 Orange	Standby during startup
 Orange	Charger mode:Charging.

 Light

 Flash

3. Protection signal

Description	Output of alarm
Overload	Red : 1 Blink/Pause  
Over voltage	Red : 2 Blink/Pause  
Over temperature / Under temperature	Red : 3 Blink/Pause  
Fan fail	Red : 4 Blink/Pause  
Others (Note)	Red : 5 Blink/Pause  
High Ambient temperature alarm	Red : Blink  

Note: Others include protection status SCP、AC UVP and EEPROM error.

※ AC IN Connector Pin No. Assignment (COMM):

Pin No.	Function	Description
1	GND_AUX	Auxiliary voltage output GND.
2	D+/CANH	For MODBus model: Data line used in MODBus interface.(Note)
		For CANBus model: Data line used in CANBus interface.(Note)
3	D-/CANL	For MODBus model: Data line used in MODBus interface.(Note)
		For CANBus model: Data line used in CANBus interface.(Note)
4	+5V_AUX	Auxiliary voltage output, 4.5-5.5V, referenced to GND_AUX (pin1)

Note: Isolated signal, referenced to GND_AUX

※ Control Pin No. Assignment (CRL):

4 2



3 1

Pin No.	Description
1,3	Pin 1 and Pin 3 are used to connect the built-in termination resistor onto the communication bus by short-circuiting these two pins or installing the jumper.
2,4	Pin 2 and Pin 4 are used to place the jumper when the unit is not the terminations.

※ AD1,AD2 switch for MODBus/CANBus interface address setting, please refer to the user manual for more details

※ Control Pin No. Assignment (PAR1,PAR2) : HRS DF11-10DP-2DS or equivalent

1 9

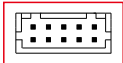

2 10

Mating Housing	HRS DF11-10DS or equivalent
Terminal	HRS DF11-10SC or equivalent

Pin No.	Function	Description
1	+5V_AUX2	Auxiliary voltage output, 4.5~5.5V, referenced to GND_AUX2 (pin2). (Only for REMOTE ON-OFF)
2	GND_AUX2	Auxiliary voltage output GND_AUX2 (pin2).
3	REMOTE ON_OFF	The unit can turn the output ON/OFF by dry contact between Remote ON/OFF and +5_AUX2.(Note 1) Short : Power ON ; Open : Power OFF
4	DC-OK	High (4.5 ~ 5.5V) : When the Vout ≤ 80%±5%. Low (-0.5 ~ 0.5V) : When Vout ≥ 80%±5%. The maximum sourcing current is 4mA and only for output. (Note.1)
5	DA	Data line used for parallel control.
6	N.C.	Blank
7	DB	Data line used for parallel control.
8	T-ALARM	High (4.5 ~ 5.5V) : When the internal temperature exceeds the limit of temperature alarm, or when any of the fans fails. Low (-0.5 ~ 0.5V) : When the internal temperature is normal, and when fans work normally. The maximum sourcing current is 4mA and only for output.(Note.1)
9	C/D Control	High (4.5 ~ 5.5V) : Battery Charging mode (Note 2) Low (0 ~ 0.5V) : Battery Discharging mode (Note 2)
10	Fault	High (4.5 ~ 5.5V) : When the Vac ≤ 165Vrms, OLP, SCP, OTP, OVP, AC Fail, fan lock, islanding protection. Low (-0.5 ~ 0.5V) : When Vac ≥ 175Vrms and when power supply work normally. The maximum sourcing current is 4mA and only for output. (Note.1)



Note 1: Isolated signal, referenced to GND_AUX2.

Note 2: Only for battery mode use.

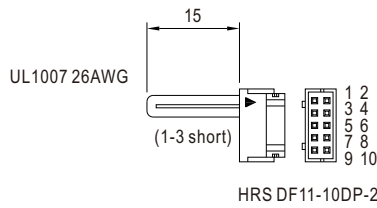
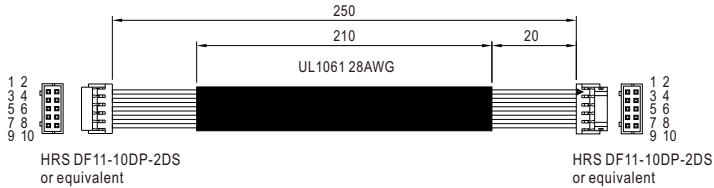
■ Accessory List

No.	Item	Quantity																				
1	<p>Remote control short wire along with BIC-5K (standard accessory)</p>  <table border="1" data-bbox="621 776 1224 867"> <tr> <td>1</td><td>2</td><td>3</td><td>4</td><td>5</td><td>6</td><td>7</td><td>8</td><td>9</td><td>10</td> </tr> <tr> <td>Green</td><td>NC</td><td>Green</td><td>NC</td><td>NC</td><td>NC</td><td>NC</td><td>NC</td><td>NC</td><td>NC</td> </tr> </table>	1	2	3	4	5	6	7	8	9	10	Green	NC	Green	NC	NC	NC	NC	NC	NC	NC	1pcs/per model
1	2	3	4	5	6	7	8	9	10													
Green	NC	Green	NC	NC	NC	NC	NC	NC	NC													
2	<p>Parallel function mating wire along with BIC-5K (standard accessory)</p>  <table border="1" data-bbox="621 1246 1224 1338"> <tr> <td>1</td><td>2</td><td>3</td><td>4</td><td>5</td><td>6</td><td>7</td><td>8</td><td>9</td><td>10</td> </tr> <tr> <td>Black</td><td>Brown</td><td>Red</td><td>Orange</td><td>Yellow</td><td>Green</td><td>Blue</td><td>Purple</td><td>Gray</td><td>White</td> </tr> </table>	1	2	3	4	5	6	7	8	9	10	Black	Brown	Red	Orange	Yellow	Green	Blue	Purple	Gray	White	1pcs/per model
1	2	3	4	5	6	7	8	9	10													
Black	Brown	Red	Orange	Yellow	Green	Blue	Purple	Gray	White													

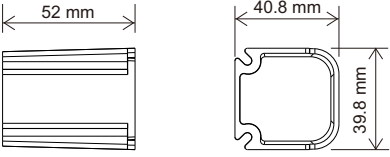
※ Terminal protector mating along with BIC-5K (Option)

	Item	Quantity
①	 	1
②		1
③		4

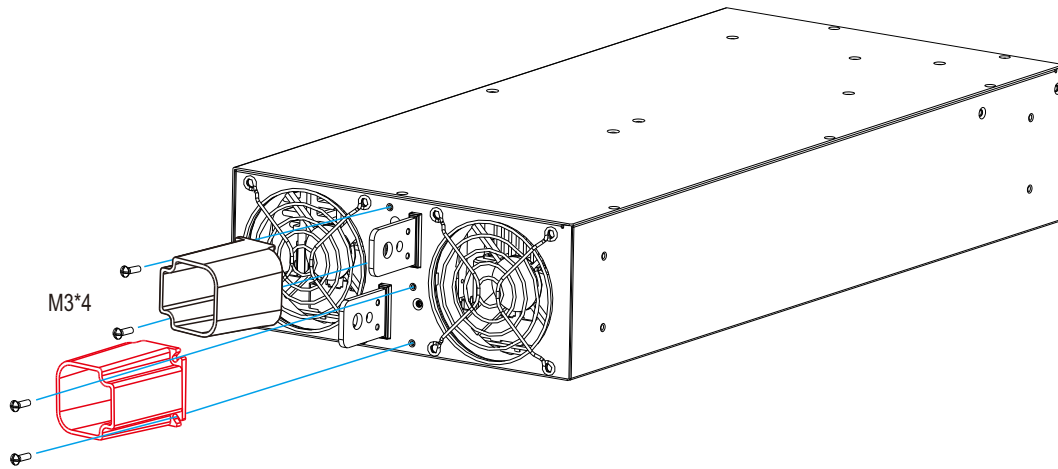

 www.simpex.ch

Besuchen Sie unseren Simpex E-Shop
mit über 12'000 Produkten.

Er bietet Ihnen eine breite Funktionsvielfalt, sowie intelligente
Suchfunktionen. Ob Sie den Shop als Einkaufsplattform oder als
Produktfinder nutzen – im Simpex E-Shop haben Sie alle Infor-
mationen schnell und tagesaktuell zur Hand.

24h und das 365 Tage im Jahr.



Hauptsitz

Simpex Electronic AG
Binzackerstrasse 33
CH-8620 Wetzikon
Telefon +41 44 931 10 10
E-Mail contact@simpex.ch
Internet www.simpex.ch

Manufaktur

Simpex Electronic SA
En Bas-le-Port 1
CH-2088 Cressier
E-Mail contact@simpex.ch
Internet www.simpex.ch