

RACPRO1-RD40 Series ◊ Redundancy Module

40A ◊ Input: DC 9-56V & 2x 20A

FEATURES

- Slim Design (43mm) with 25° Push-In connectors
- Fast tool-less mounting and demounting
- Wide DC-Input Range 9V to 56V
- Operation with 12V, 24V & 48V power supplies
- Highest Efficiency up to 99.5%
- Very Low Voltage Drop 140mV
- Minimum Power Loss 5W typ.
- Reduced no load power consumption <200mW
- Operating temperature -40°C/+70°C
- Full Power -40°C/+70°C//Power Boost 150%/5s
- Highest Lifetime Expectancy 268.000h/40°C
- Made in Europe
- 3 year warranty



Dimensions (HxWxD): 135.0 x 43.0 x 140.4mm (5.3 x 2.0 x 6.1 inch)
260g (0.57 lbs)

APPLICATIONS

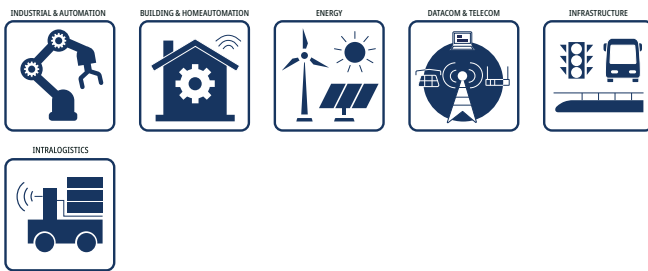

SAFETY & EMC



DESCRIPTION

The light and slim RACPRO1-RD40 is a high reliability n+1 DIN Rail redundancy diode module in extremely compact dimensions of 135 x 140.4mm with a width of only 43mm. The wide DC input range of 9V to 56V allows connection of Power Supplies with 12V, 24V or 48V outputs in n+1 redundancy operation up to 20A or up to 40A output in sharing or parallel operation. With highly efficient MOSFET-technology the module specially designed for demanding applications in the harsh industrial automation field with only 140mV voltage drop. These units will deliver up to 40A over the full -40°C to +70°C ambient temperature range with only convection cooling and maximum power loss of 5W typ. The unique and innovative modern design with 25° push-in connectors allows easy tool-less installation or replacement. The product is certified according to the global safety standards IEC/EN/UL/CSA 62368-1. Electromagnetic radiated and conducted emissions are compliant to heavy industrial EN 61000-6-4 Class B emission standard and EN 61000-6-2 immunity standard.

SELECTION GUIDE

Part Number	Input Voltage Range [VDC]	Output Voltage nom. [VDC]	Input Current [A]	Output Current Redundancy Mode [A]	Output Current Parallel Mode [A]	Efficiency ⁽¹⁾ typ. [%]
RACPRO1-RD40	9-56	12/24/48	2x 20A	2x 20A	40A	99.5

Note1: Efficiency is tested at nominal input (12/24/48VDC) and full load (all channels) at +25°C ambient.

RACPRO1-RD40 Series ◇ Redundancy Module

40A ◇ Input: DC 9-56V & 2x 20A

BASIC CHARACTERISTICS (measured @ $T_{AMB} = 25^{\circ}C$, nom. V_{IN} and after warm-up unless otherwise stated)

Parameter	Condition	Min.	Typ.	Max.
Nominal Input Voltage		12VDC		48VDC
Operating Range		9VDC		56VDC
Turn-on Voltage				9VDC
Turn-off Voltage				7VDC
Input Current				2x 20A
No Load Power Consumption	$V_{OUT} = 24VDC$		200mW	
	$V_{OUT} = 48VDC$		400mW	
Nominal Output Voltage			12/24/48VDC	
Output Current				40A
	5sec max. ⁽²⁾ , refer to „Boost Power“			60A
Voltage Drop	I/P to O/P, refer to „Input to Output Voltage Drop“	Input: 1x 20A	140mV	
		Input: 2x 20A	140mV	
Minimum Load		0%		
Ripple and Noise	20MHz bandwidth	depends on input devices		
Output Capacitance		depends on input devices		

Note2: For use with all RACPRO1 power supplies. For other use case, please contact RECOM techsupport.
Refer to „Boost Power“

Input to Output Voltage Drop

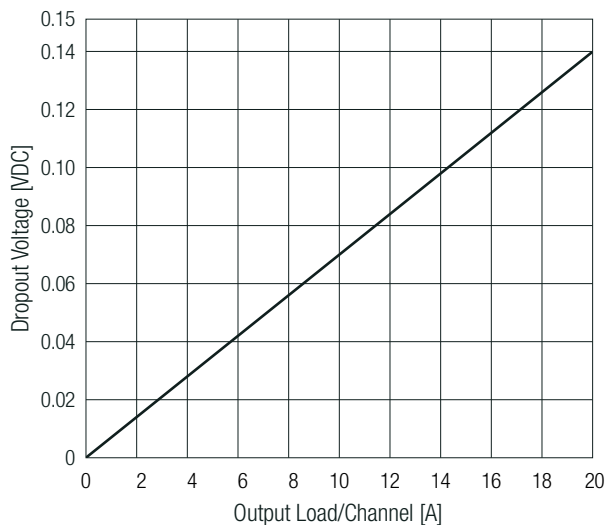

BLOCK DIAGRAM

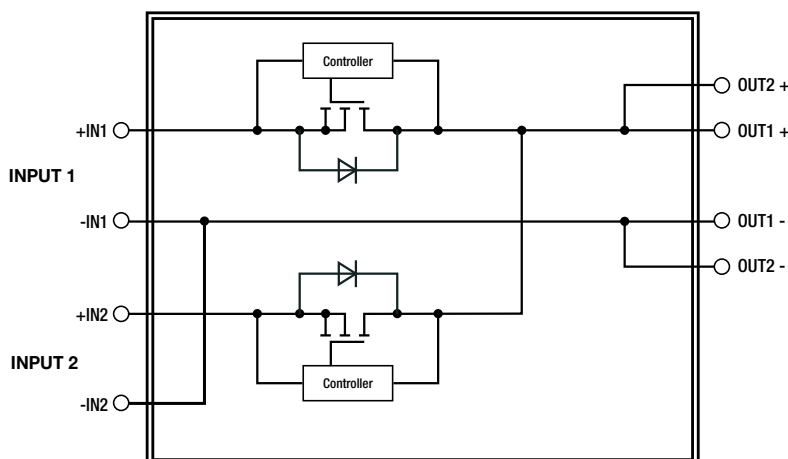

REDUNDANCY CONFIGURATION

Each input channel is supplied with half the nominal input current. In case one power supply fails, the other power supply supplies the missing input current so that the output remains unchanged (1+1 redundancy).

Each power supply needs to be able to supply the full output current at any given time.

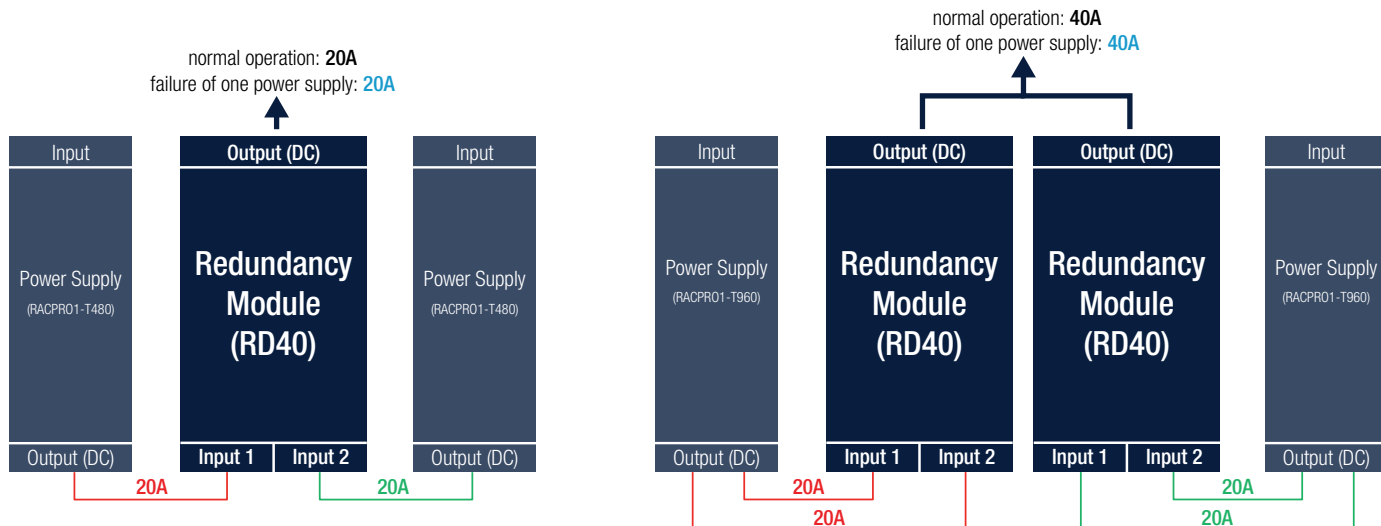

PARALLEL MODE

Each input channel is supplied with its full nominal input current, resulting in the full nominal value of the output current. In case one power supply fails, the output current drops.

For parallel operation at 40 A, two redundancy modules must be used, as each input is rated for a maximum of 20 A.

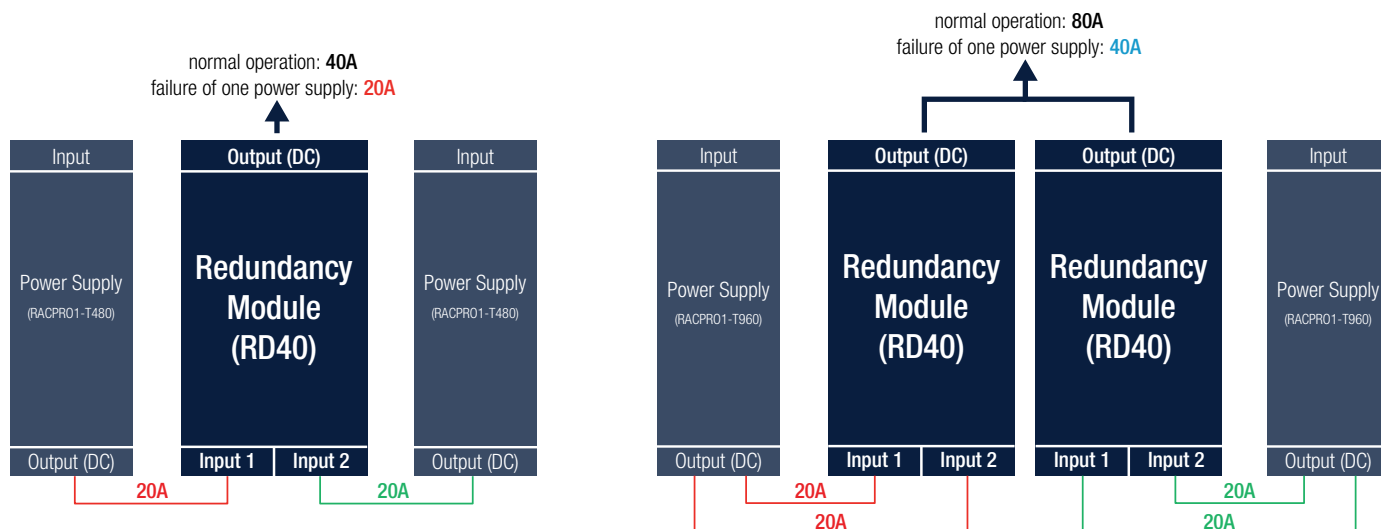

RACPR01-RD40 Series ◊ Redundancy Module

40A ◊ Input: DC 9-56V & 2x 20A

PROTECTIONS (measured @ $T_{AMB} = 25^{\circ}\text{C}$, nom. V_{IN} and after warm-up unless otherwise stated)

Parameter	Type	Value
Internal Input Fuse		no
Short Circuit Protection (SCP)		depending on input devices
Return Voltage Immunity	continuous	63VDC max.
	<5 min	70VDC max.
Reverse Current		5mA max.
Reverse Polarity Protection		unit does not start when input voltage is reversed
Over Voltage Category (OVC)		OVC III (4000m)
Class of Equipment		Class 3

ENVIRONMENTAL (measured @ $T_{AMB} = 25^{\circ}\text{C}$, nom. V_{IN} and after warm-up unless otherwise stated)

Parameter	Condition		Value
Operating Ambient Temperature Range	@ natural convection (0.1m/s)		-40°C to +70°C
Operating Altitude ⁽³⁾	refer to „Altitude Derating“		4000m (OVC III)
Operating Humidity	non-condensing		95% RH max.
Pollution Degree			PD2
IP Rating			IP20
Shock	according to IEC 60068-2-27 Fa	non-operating	15G/11ms, 3 times (positive/negative) in all axis
Vibration	according to IEC 60068-2-6 Fc	non-operating	5 - 8.4Hz @ 3.5mm deflection 8.4 -150Hz @ 2G, 10 cycles /axis(min-max-min); 1 octave/min
MTBF	according to EN/IEC 61709 (SN29500)	$T_{AMB} = 40^{\circ}\text{C}$	2600 x 10 ³ hours
Design Lifetime	$T_{AMB} = 40^{\circ}\text{C}$ @ 100% Load		268 x 10 ³ hours

Note3: Recognized by safety agency for safe operation up to 5000m. High altitude operation may impact the performance and lifetime

Derating Graph

(Standard and upside down mounting orientation)

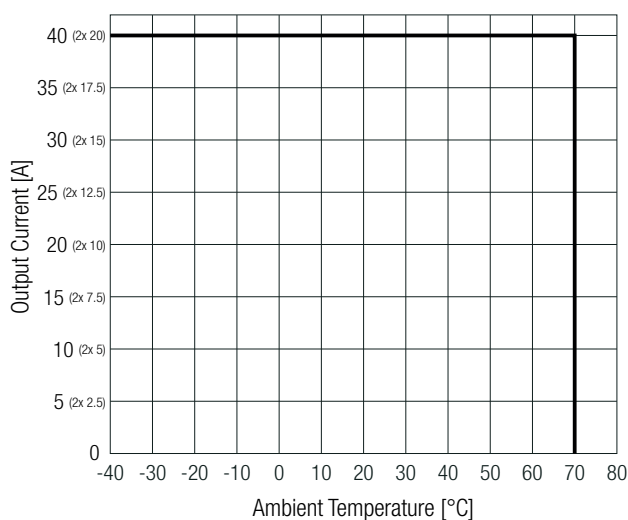

Altitude Derating

(Standard and upside down mounting orientation, $T_{AMB} = +60^{\circ}\text{C}$)

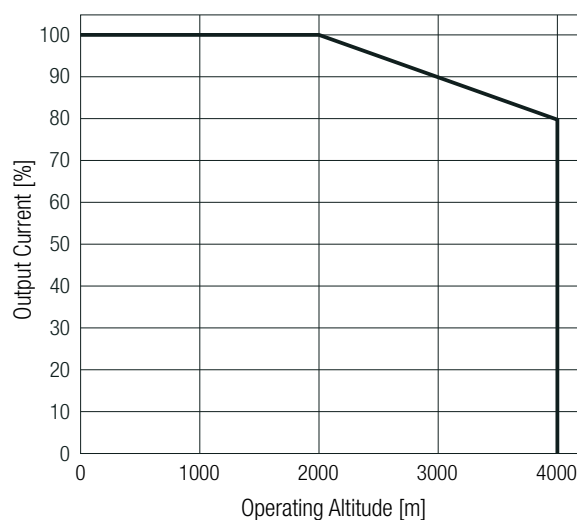

Note4: Above derating graph is valid for standard and upside-down mounting orientation only. For all other mounting orientations, the maximum output power must be reduced by 15% of the nominal power.

RACPR01-RD40 Series ◊ Redundancy Module

40A ◊ Input: DC 9-56V & 2x 20A

ADDITIONAL FEATURES (only valid when using RACPR01 power supply units)

The functions listed below only apply when operating with RACPR01 power supplies. The duration of the boost power function “x” is defined by the respective power supply and is specified in the corresponding RACPR01 data sheet.

Boost Power

(Standard & upside down mounting orientation only, -40°C to +60°C max.)

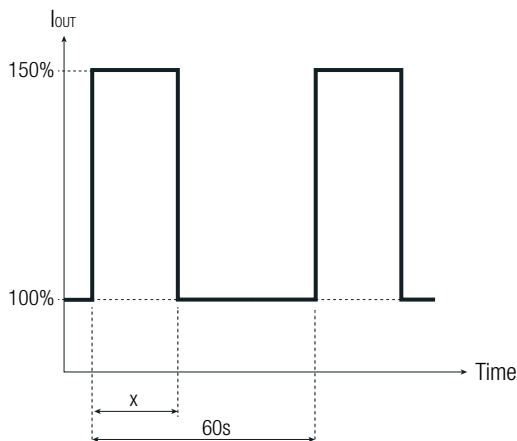

Easy Fuse tripping

(-40°C to +60°C max.)

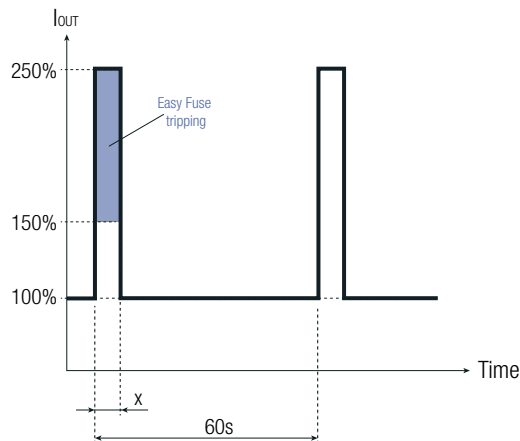

SAFETY & CERTIFICATIONS

Certificate Type (Safety)	Report Number	Standard
Audio/Video, information and communication technology equipment - Part 1: Safety requirements (CB)	E224736-A6032-CB-1	IEC62368-1:2018 3rd Edition
Audio/Video, information and communication technology equipment - Part 1: Safety requirements		EN IEC 62368-1:2020+A11:2020
Audio/Video, information and communication technology equipment - Part 1: Safety requirements	E224736-A6032-UL	UL62368-1:2019 3rd Edition CAN/CSA-C22.2 No. 62368-1-19 3rd Edition
RoHS2		RoHS 2011/65/EU + AM2015/863

EMC Compliance according to IEC/EN61000-6-4/6-2	Condition	Standard / Criterion
Electromagnetic compatibility (EMC) - Part 6-2: Generic standards - Immunity standard for industrial environments		EN61000-6-2:2005+AC:2005
Electromagnetic compatibility (EMC) - Part 6-3: Generic standards - Emission standard for residential area		EN61000-6-3:2007+A1:2011+AC:2012
ESD Electrostatic discharge immunity test	Air: ±2, 4, 6, 8kV; Contact: ±2, 4, 6, 8kV	IEC61000-4-2:2008, Criteria A EN61000-4-2:2009, Criteria A
Radiated, radio-frequency, electromagnetic field immunity test	10V/m (80-1000MHz)	IEC/EN61000-4-3:2006+A2:2010, Criteria A
Fast Transient and Burst Immunity	DC Power Port: ±2kV DC Output Port: ±2kV	IEC/EN61000-4-4:2012, Criteria A
Surge Immunity	DC Power Port: Symmetric: 1kV Asymmetric: 2kV	IEC/EN61000-4-5:2014+A1:2017, Criteria A
	DC Output Port: Symmetric: 1kV Asymmetric (Input to DIN-rail (PE)): 1kV	
Immunity to conducted disturbances, induced by radio-frequency fields	10Vrms (0.15-80MHz)	IEC61000-4-6:2013, Criteria A EN61000-4-6:2014, Criteria A

RACPR01-RD40 Series ◊ Redundancy Module

40A ◊ Input: DC 9-56V & 2x 20A

DIMENSION & PHYSICAL CHARACTERISTICS

Parameter	Type	Value
Material	chassis	polycarbonate (UL94 V-0) / aluminum
Dimension (HxWxD)		135.0 x 43.0 x 140.4mm 5.3 x 2.0 x 6.1 inch
Weight		260g 0.57 lbs

Dimension Drawing (mm)

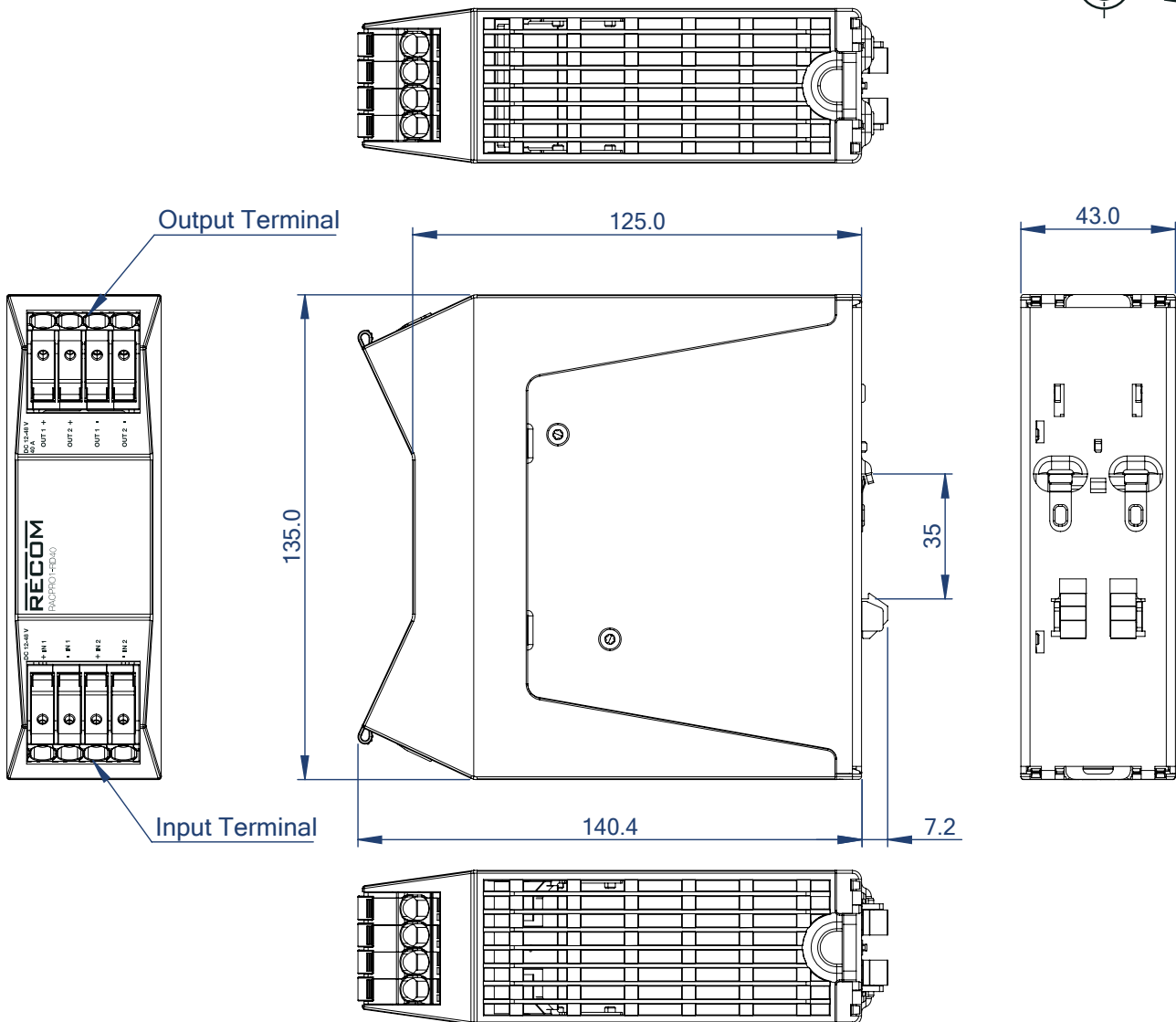
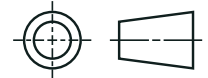

Tolerance: ±0.5mm

Input & Output Cage Clamp

Connector	AWG	mm ²
Input	24-8	0.25-6
Output	24-8	0.25-6

Wire stripping length: 12-13mm

Note5: It is recommended to use flexible (stranded) or solid cables with the above mentioned cross-section. Ferrules are required for flexible cables. Use copper conductors designed for an operating temperature of at least 105°C. Each terminal connection is only approved for a current of up to 35A. For higher output currents, it is necessary to connect the pole pairs of the output terminal in parallel.

INSTALLATION & APPLICATION

Mounting Instruction

Mounting Rail: Standard TS35 DIN Rail in accordance with EN 60715.

Mounting

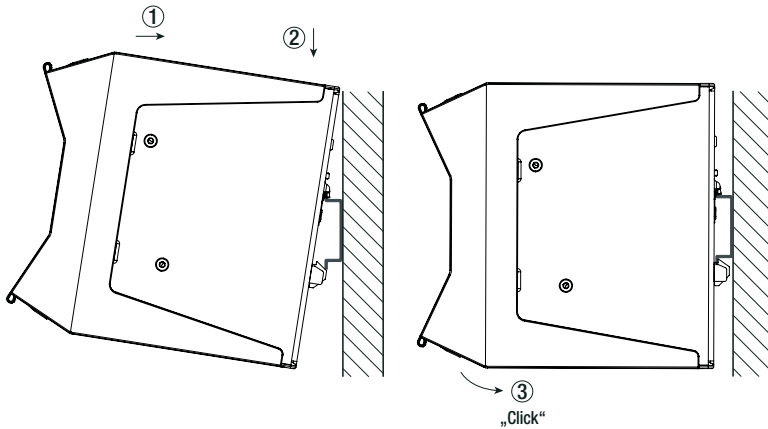

1. Place the device on the DIN rail with a slight upward tilt. Snap the device into the DIN rail.
2. Now tilt the device downwards until it reaches the lower part of the DIN rail.
3. Press the lower part of the device firmly against the rail until the device locks into position on the DIN rail.
4. To make sure it is securely locked in place, give the device a gentle shake.

Release Option 1 (tool-less)

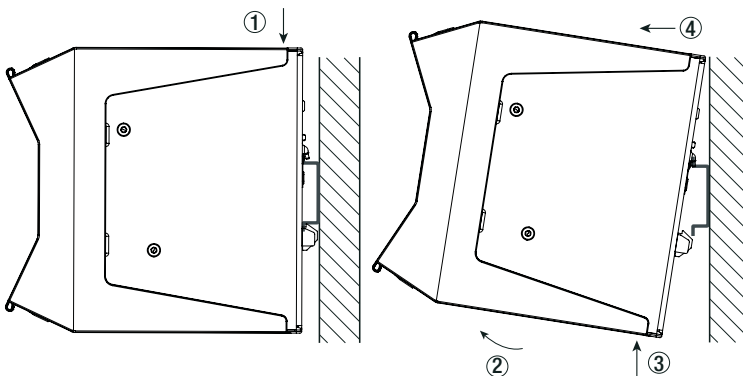

1. Press the unlock button on the top of the device to release the latch from the rail.
2. While pushing the button, slightly tilt the device forward.
3. Pull the device away from the DIN rail by pushing it up.
4. Remove the power supply completely from the rail.

Release Option 2 (by using a screwdriver)

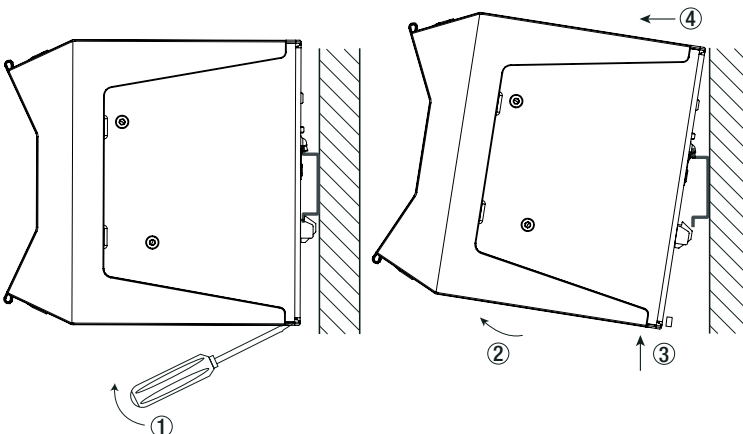

1. Pull the DIN rail latch by using a screwdriver OUT of the device and HOLD it.
2. Tilt the bottom of the device OUT.
3. Pull the device away from the DIN rail by pushing it up.
4. Remove the power supply completely from the rail.

RACPR01-RD40 Series ◊ Redundancy Module

40A ◊ Input: DC 9-56V & 2x 20A

INSTALLATION & APPLICATION

Installation Instructions

To guarantee sufficient convection cooling, keep a distance of 20mm above and below the device.

For vertical mounting the device should be installed with the input terminal on bottom side (standard mounting orientation). Mounting with the output terminals at the bottom (upside-down) has no impact on the thermal behavior.

For all other mounting orientations, the maximum output power must be reduced by 15% of the nominal power.

No space between supplies is required when the PSUs are from RECOM RACPR01 series.

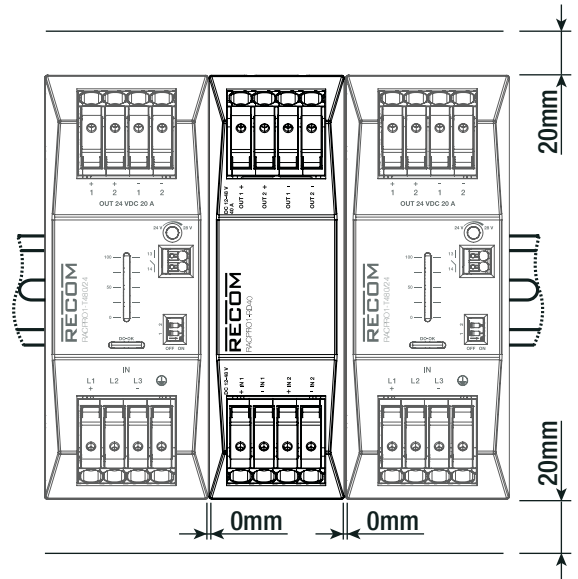

PACKAGING INFORMATION

Parameter	Type	Value
Packaging Dimension (LxWxH)	cardboard box	175.0 x 166.0 x 59.0mm
Packaging Quantity		1 pc
Storage Temperature Range		-40°C to +85°C
Storage Humidity	non-condensing	85% RH max.

The product information and specifications may be subject to changes even without prior written notice. The product has been designed for various applications; its suitability lies in the responsibility of each customer. The products are not authorized for use in safety-critical applications without RECOM's explicit written consent. A safety-critical application is an application where a failure may reasonably be expected to endanger or cause loss of life, inflict bodily harm or damage property. The applicant shall indemnify and hold harmless RECOM, its affiliated companies and its representatives against any damage claims in connection with the unauthorized use of RECOM products in such safety-critical applications.

 www.simpex.ch

Besuchen Sie unseren Simpex E-Shop mit über 12'000 Produkten.

Er bietet Ihnen eine breite Funktionsvielfalt, sowie intelligente Suchfunktionen. Ob Sie den Shop als Einkaufsplattform oder als Produktfinder nutzen – im Simpex E-Shop haben Sie alle Informationen schnell und tagesaktuell zur Hand.

24h und das 365 Tage im Jahr.



Hauptsitz

Simpex Electronic AG
Binzackerstrasse 33
CH-8620 Wetzikon
Telefon +41 44 931 10 10
E-Mail contact@simpex.ch
Internet www.simpex.ch

Manufaktur

Simpex Electronic SA
En Bas-le-Port 1
CH-2088 Cressier
E-Mail contact@simpex.ch
Internet www.simpex.ch