

Current Transducer LA 305-S/SP1

$$I_{PN} = 500 \text{ A}$$

For the electronic measurement of currents : DC, AC, pulsed..., with a galvanic isolation between the primary circuit (high power) and the secondary circuit (electronic circuit).



16173

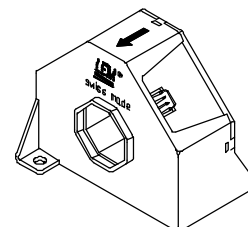

Electrical data

I_{PN}	Primary nominal r.m.s. current	500	A					
I_P	Primary current, measuring range	0 .. ± 800	A					
R_M	Measuring resistance @	$T_A = 70^\circ\text{C}$		$T_A = 85^\circ\text{C}$				
		$R_{M \min}$	$R_{M \max}$	$R_{M \min}$	$R_{M \max}$			
		with $\pm 12 \text{ V}$	@ $\pm 500 \text{ A}_{\max}$	0	15	0	14	Ω
			@ $\pm 750 \text{ A}_{\max}$	0	1	0 ¹⁾	2 ¹⁾	Ω
	with $\pm 15 \text{ V}$	@ $\pm 500 \text{ A}_{\max}$	1.2	25	9	24	Ω	
		@ $\pm 800 \text{ A}_{\max}$	1.2	6	9 ¹⁾	9 ¹⁾	Ω	
I_{SN}	Secondary nominal r.m.s. current	250	mA					
K_N	Conversion ratio	1 : 2000						
V_C	Supply voltage ($\pm 5 \%$)	$\pm 12 \dots 15$	V					
I_C	Current consumption	20 (@ $\pm 15 \text{ V}$) + I_S	mA					
V_b	R.m.s. rated voltage ²⁾ , safe separation		1750	V				
		basic isolation	3500	V				

Features

- Closed loop (compensated) current transducer using the Hall effect
- Insulated plastic case recognized according to UL 94-V0.

Special features

- $I_{PN} = 500 \text{ A}$
- $I_P = 0 \dots \pm 800 \text{ A}$
- $K_N = 1 : 2000$
- Partly potted.

Advantages

- Excellent accuracy
- Very good linearity
- Low temperature drift
- Optimized response time
- Wide frequency bandwidth
- No insertion losses
- High immunity to external interference
- Current overload capability.

Applications

- AC variable speed drives and servo motor drives
- Static converters for DC motor drives
- Battery supplied applications
- Uninterruptible Power Supplies (UPS)
- Switched Mode Power Supplies (SMPS)
- Power supplies for welding applications.

Accuracy - Dynamic performance data

X_G	Overall accuracy @ I_{PN} , $T_A = 25^\circ\text{C}$	± 0.8	%
e_L	Linearity error	< 0.1	%
I_O	Offset current @ $I_P = 0$, $T_A = 25^\circ\text{C}$	Typ	Max
			± 0.25 mA
I_{OM}	Residual current ³⁾ @ $I_P = 0$, after an overload of $3 \times I_{PN}$		± 0.50 mA
I_{OT}	Thermal drift of I_O - $10^\circ\text{C} \dots + 85^\circ\text{C}$	± 0.15	± 0.30 mA
t_{ra}	Reaction time @ 10 % of I_{PN}	< 500	ns
t_r	Response time ⁴⁾ @ 90 % of I_{PN}	< 1	μs
di/dt	di/dt accurately followed	> 100	A/ μs
f	Frequency bandwidth (- 3 dB)	DC .. 100	kHz

General data

T_A	Ambient operating temperature	- 10 .. + 85	$^\circ\text{C}$
T_S	Ambient storage temperature	- 40 .. + 90	$^\circ\text{C}$
R_S	Secondary coil resistance @	$T_A = 70^\circ\text{C}$	27 Ω
		$T_A = 85^\circ\text{C}$	28 Ω
m	Mass Standards ⁵⁾		230 g
			EN 50178 : 1997

- Notes :**
- ¹⁾ Measuring range limited to $\pm 710 \text{ A}_{\max}$
 - ²⁾ Pollution class 2. With a non insulated primary bar which fills the through-hole
 - ³⁾ The result of the coercive field of the magnetic circuit
 - ⁴⁾ With a di/dt of 100 A/ μs
 - ⁵⁾ A list of corresponding tests is available.

060628/5

Dimensions LA 305-S/SP1 (in mm. 1 mm = 0.0394 inch)

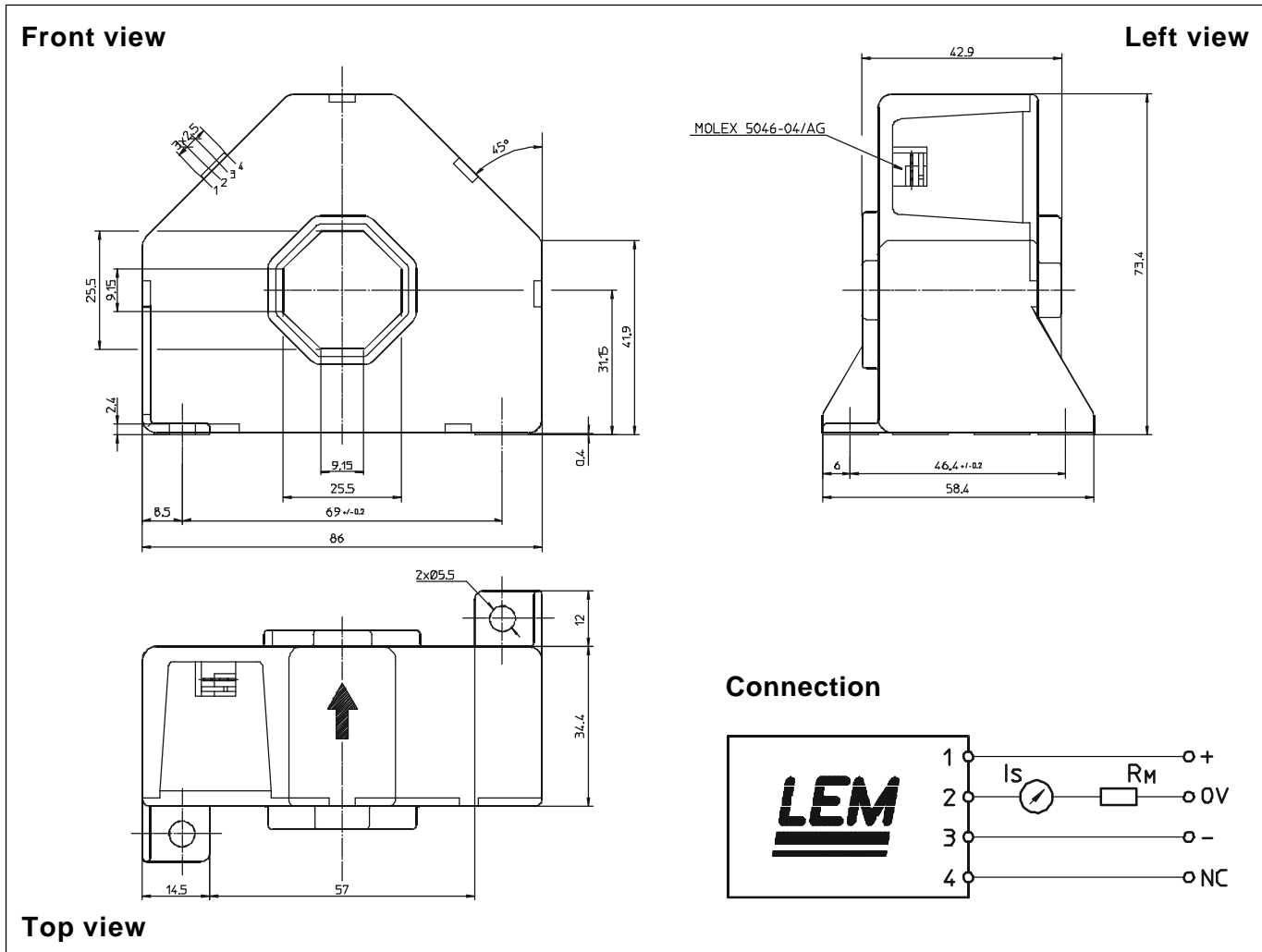

Mechanical characteristics

- General tolerance ± 0.5 mm
- Transducer fastening 2 holes $\varnothing 5.5$ mm
2M5 steel screws
Fastening torque, max. 4 Nm or 2.95 Lb. - Ft.
- Primary through-hole 25.5 x 25.5 mm
- Connection of secondary Molex 5046-04/AG

Remarks

- I_s is positive when I_p flows in the direction of the arrow.
- Temperature of the primary conductor should not exceed 100°C.
- Dynamic performances (di/dt and response time) are best with a single bar completely filling the primary hole.

 www.simpex.ch

Besuchen Sie unseren Simpex E-Shop mit über 12'000 Produkten.

Er bietet Ihnen eine breite Funktionsvielfalt, sowie intelligente Suchfunktionen. Ob Sie den Shop als Einkaufsplattform oder als Produktfinder nutzen – im Simpex E-Shop haben Sie alle Informationen schnell und tagesaktuell zur Hand.

24h und das 365 Tage im Jahr.



Hauptsitz

Simpex Electronic AG
Binzackerstrasse 33
CH-8620 Wetzikon
Telefon +41 44 931 10 10
E-Mail contact@simpex.ch
Internet www.simpex.ch

Manufaktur

Simpex Electronic SA
En Bas-le-Port 1
CH-2088 Cressier
E-Mail contact@simpex.ch
Internet www.simpex.ch