



DC input side



AC output side



IEC62368-1 EN62368-1 (for 112/124/148 TB type only)
Please refer to page3 for more details.



Features

- Built-in UPS function (AC by-pass)
- True sine wave output (THD<3%)
- High surge power up to 4400W
- Temperature controlled cooling fan
- AC output voltage and frequency selectable by DIP S.W
- -25°C ~+70°C wide operating temperature
- Power ON-OFF remote control
- Front panel indicator for operation status
- Protections :

Input : Reverse polarity / DC. low alarm / DC low shutdown / Over voltage

Output : Short circuit / Overload / Over temp.

- Battery over discharge protection (low voltage disconnect)
- Suitable for lead-acid or li-ion batteries
- Remote controller

(IRC1, IRC2, IRC3 accessory sold separately, please refer to: <https://www.meanwell.com/webapp/product/search.aspx?prod=IRC1>)

- Support RS-232 communication(Communication cable order No.: RJ11-RS232, sold sperately)
- Carry handle accessory available(Order NO.: Carry handle, sold separately)
- Conformal coating
- 3 years warranty

Applications

- Home and office appliance
- Power tools
- Portable equipment
- Vehicle
- Yacht
- Off-grid solar power system

GTIN CODE

MW Search: <https://www.meanwell.com/serviceGTIN.aspx>

Description

NTU-2200 is a 2200W highly reliable off-grid true sine wave DC-AC power inverter with built-in UPS function. Its key features include: digital design with MCU control, streamlined control circuitry that quickly responds to environmental changes and improves reliability, high quality fan with low acoustic noise, 4400W peak power, adjustable AC output voltage and frequency, -25~+70°C wide operating temperature range, complete protection features, and etc. Combined with batteries, the NTU-2200 is suitable for use in residential, commercial, marine, automobile, mine, construction site, and remote areas with no access to utility power, and the output can be used to power fans, TV, radio, phone charger, PC/laptop, lighting, induction stove, air conditioner, electromechanical tool, communication equipment, power distribution cabinet, outdoor camping equipment, marine AC power, factory equipment, and etc.

Model Encoding

NTU - 2200 - 1 12 US

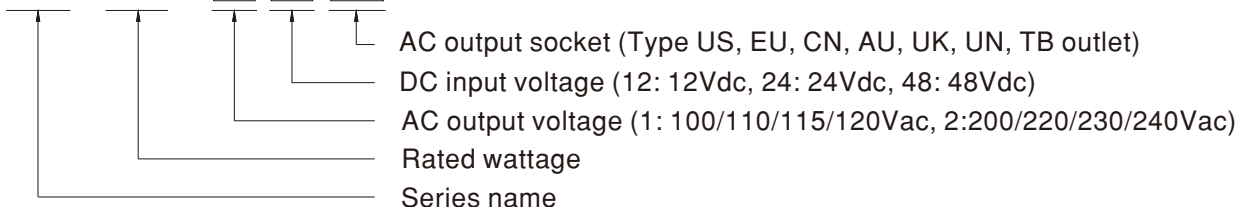

SPECIFICATION

MODEL NO.		NTU-2200-112 <input type="checkbox"/>	NTU-2200-124 <input type="checkbox"/>	NTU-2200-148 <input type="checkbox"/>	NTU-2200-212 <input type="checkbox"/>	NTU-2200-224 <input type="checkbox"/>	NTU-2200-248 <input type="checkbox"/>		
		<input type="checkbox"/> = US, UN, TB			<input type="checkbox"/> = EU, CN, AU, UK, UN, TB				
AC OUTPUT	RATED POWER(Continuous)	2200W			2200W				
	OVER RATED POWER(3 Min.)	2530W			2530W				
	PEAK POWER(10 Sec.)	3300W			3300W				
	SURGE POWER(30 Cycles)	4400W			4400W				
	AC VOLTAGE	Factory setting set at 110VAC 100 / 110 / 115 / 120Vac selectable by DIP S.W			Factory setting set at 230VAC 200 / 220 / 230 / 240Vac selectable by DIP S.W				
	FREQUENCY	Factory setting set at 60 ± 0.1Hz 50/60Hz selectable by DIP S.W			Factory setting set at 50 ± 0.1Hz 50/60Hz selectable by DIP S.W				
	WAVEFORM Note.1	True sine wave (THD<3%)							
	AC REGULATION	± 3.0% at rated output voltage							
FRONT PANEL LED	Please see page 5								
DC INPUT	DC VOLTAGE	12Vdc	24Vdc	48Vdc	12Vdc	24Vdc	48Vdc		
	VOLTAGE RANGE (Typ.)	10 ~ 16.5Vdc	20 ~ 33Vdc	40 ~ 66Vdc	10 ~ 16.5Vdc	20 ~ 33Vdc	40 ~ 66Vdc		
	DC CURRENT (Typ.)	250A	120A	60A	250A	120A	60A		
	NO LOAD DISSIPATION (SAVING MODE)(Typ.) Note.2	Default disable, auto detect AC output load ≤ 10W will be changed to saving mode <15W							
	OFF MODE CURRENT DRAW	≤ 2mA							
	EFFICIENCY (Typ.) Note.1	89%	90%	91%	90%	92%	93%		
	BATTERY TYPES	Lead Acid or li-ion							
PROTECTION	DC INPUT	FUSE (INTERNAL)	40A*8	40A*4	25A*4	40A*8	40A*4	25A*4	
		LOW	ALARM	11 ± 0.3Vdc	22 ± 0.5Vdc	44 ± 1Vdc	11 ± 0.3Vdc	22 ± 0.5Vdc	44 ± 1Vdc
			SHUTDOWN	10 ± 0.3Vdc	20 ± 0.5Vdc	40 ± 1Vdc	10 ± 0.3Vdc	20 ± 0.5Vdc	40 ± 1Vdc
			RESTART	12.5 ± 0.3Vdc	25 ± 0.5Vdc	50 ± 1Vdc	12.5 ± 0.3Vdc	25 ± 0.5Vdc	50 ± 1Vdc
		HIGH	ALARM	15.5 ± 0.3Vdc	31 ± 0.5Vdc	62 ± 1Vdc	15.5 ± 0.3Vdc	31 ± 0.5Vdc	62 ± 1Vdc
	SHUTDOWN		16.5 ± 0.3Vdc	33 ± 0.5Vdc	66 ± 1Vdc	16.5 ± 0.3Vdc	33 ± 0.5Vdc	66 ± 1Vdc	
	RESTART		15 ± 0.3Vdc	30 ± 0.5Vdc	60 ± 1Vdc	15 ± 0.3Vdc	30 ± 0.5Vdc	60 ± 1Vdc	
	BAT. POLARITY		By internal fuse open						
	AC OUTPUT	OVER TEMPERATURE	Protection type : Shut down o/p voltage, re-power on to recover						
		OUTPUT SHORT	Protection type : Shut down o/p voltage, re-power on to recover						
OVER LOAD (Typ.)		105 ~ 115% load for 180 sec., 115% ~ 150% load for 10 sec. Protection type : Shut down o/p voltage, re-power on to recover							
CIRCUIT BREAKER		25A			15A				
TB TYPE		UL458 (Only for "TB" type AC socket)			None				
FUNCTION	REMOTE CONTROL	CONNECTOR ACCESSORY	Power ON-OFF remote control by front panel dry contact connector(by RELAY), Open : Normal work ; Short : Remote off Remote controller sold separately, Order No.: IRC1,IRC2,IRC3						
	RS-232 COMMUNICATION		RS-232 ~ RJ11 Type connector (Please refer to page 4 for more details)						
AC UPS MODE	AC INPUT RANGE	100/110/115/120Vac ± 16%, recover ± 13%			200/220/230/240Vac ± 16%, recover ± 13%				
	FREQUENCY RANGE	45 ~ 65Hz							
	TRANSFER TIME(Typ.)	10ms inverter → AC by pass							
ENVIRONMENT	WORKING TEMP.	-25 ~ +70°C (Refer to "Derating curve")							
	WORKING HUMIDITY	20% ~ 90% RH non-condensing							
	STORAGE TEMP., HUMIDITY	-30 ~ +70°C / -22 ~ +158°F, 10 ~ 95% RH non-condensing							
	VIBRATION	10 ~ 500Hz, 3G 10min./1cycle, 60min. each along X, Y, Z axes							
SAFETY & EMC (Note.5)	SAFETY STANDARDS		CB IEC62368-1, Dekra Seal BS EN/EN62368-1, UL458, E13, EAC TP TC 004, AS/NZS 62368.1 approved (Please refer to next page "AC output socket" table for more details)						
	WITHSTAND VOLTAGE		DC I/P - AC I/P: 3.0KVAC DC I/P - AC O/P: 3.0KVAC AC O/P - FG: 1.5KVAC						
	EMC EMISSION	Radiated	Parameter	Standard			Test Level / Note		
				FCC for 112, 124, 148 only(expect for Type-UN)			Class A		
			BS EN/EN55032(CISPR32) for 212, 224, 248 only(expect for Type-UN)			Class A			
		Conducted		FCC for 112, 124, 148 only(expect for Type-UN)			Class A		
				BS EN/EN55032(CISPR32) for 212, 224, 248 only(expect for Type-UN)			Class A		
	Harmonic Current		BS EN/EN61000-3-2			Class A			
	Voltage Flicker	BS EN/EN61000-3-3			----				
	EMC IMMUNITY			BS EN/EN55024, BS EN/EN55035					
		Parameter	Standard		Test Level / Note				
		ESD	BS EN/EN61000-4-2		Level 3, 8KV air ; Level 2, 4KV contact				
		Radiated	BS EN/EN61000-4-3		Level 2				
		EFT / Burst	BS EN/EN61000-4-4		Level 2, 1KV				
		Surge	BS EN/EN61000-4-5		Level 3, 1KV/Line-Line 2KV/Line-Earth				
		Conducted	BS EN/EN61000-4-6		Level 2				
		Magnetic Field	BS EN/EN61000-4-8		Level 1				
	Voltage Dips and Interruptions	BS EN/EN61000-4-11		>95% dip 0.5 periods, 30% dip 25 periods, >95% interruptions 250 periods					
OTHERS	MTBF	344.9K hrs min. Telcordia TR/SR-332 (Bellcore) ; 34.8K hrs min. MIL-HDBK-217F (25°C)							
	DIMENSION	420*270*98mm (L*W*H)							
	PACKING	8.6Kg; 1pcs/ 10.4Kg/ 1.39CUFT							
NOTE	1.Efficiency, AC regulation and THD are tested by 1650W load, linear load at 12.5Vdc/25Vdc/50Vdc input voltage.								
	2.No load dissipation at non-saving mode(Typ.): 112/124/148 for 25W, 212/224/248 for 55W.								
	3.All parameters not specified above are measured at rated load, 25°C of ambient temperature and set to factory setting.								
	4.Internal pre-start circuit, the setup time is 8s.								
	5.The power supply is considered as an independent unit, but the final equipment still need to re-confirm that the whole system complies with the EMC directives. For guidance on how to perform these EMC tests, please refer to "EMI testing of component power supplies." (as available on https://www.meanwell.com/Upload/PDF/EMI_statement_en.pdf) ※ Product Liability Disclaimer : For detailed information, please refer to https://www.meanwell.com/serviceDisclaimer.aspx								

AC Output Socket

MODEL NO.	NTU-2200-112 <input type="checkbox"/>	NTU-2200-124 <input type="checkbox"/>	NTU-2200-148 <input type="checkbox"/>
Socket type			
	TYPE-US	TYPE-UN	TYPE-TB
	In Stock	In Stock	In Stock
Country	USA	UNIVERSAL	UNIVERSAL
Certificate	CB FC	None	CB FC

MODEL NO.	NTU-2200-212 <input type="checkbox"/>		NTU-2200-224 <input type="checkbox"/>		NTU-2200-248 <input type="checkbox"/>	
Socket type						
	TYPE-EU	TYPE-CN	TYPE-UK	TYPE-TB	TYPE-AU	TYPE-UN
	In Stock	In Stock	By request	In Stock	By request	In Stock
Country	EUROPE	CHINA	U.K	UNIVERSAL	AUSTRALIA	UNIVERSAL
Certificate	CB EAC CE				CB EAC CE	

DERATING CURVE

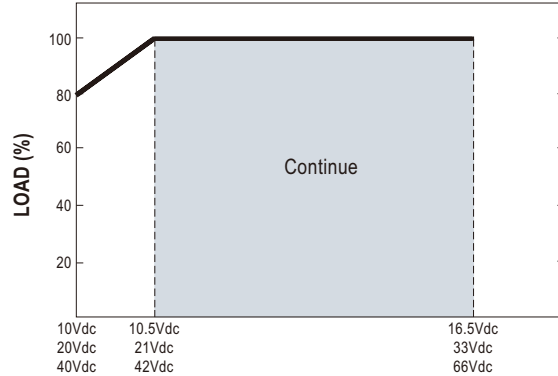
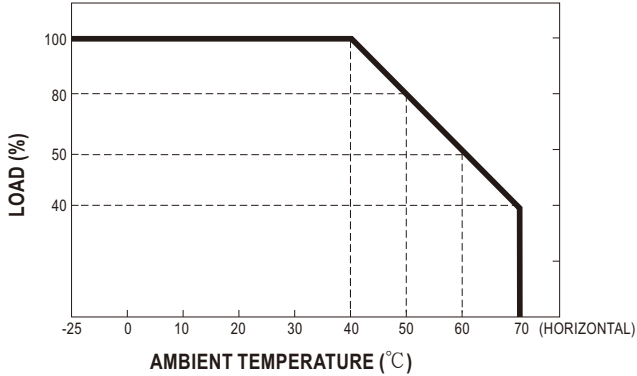

Block Diagram

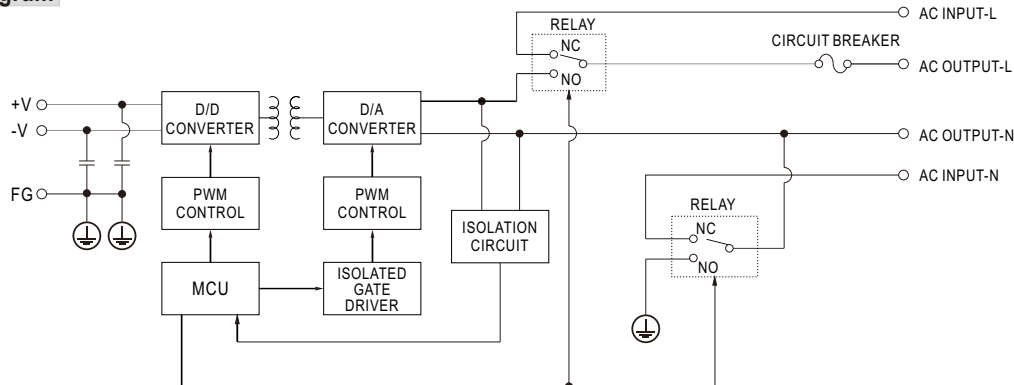

Note:

- The inverter operates in AC bypass mode when the AC input is connected and remains within $\pm 16\%$ of the AC output setting. During this mode, energy from the AC input is directly supplied to the loads. Conversely, the inverter switches to inverter mode when there is no AC input available or the AC input exceeds $\pm 16\%$ of the AC output setting.
- The relationship between the AC receptacle Earth and AC output-N is shown in the table below.
- The AC receptacle earth and FG are electrically identical in the hardware and are shorted together.
- The bypass relays remain in NC position when the inverter is turned off. As a result, energy from the AC input can still pass through the inverter to the loads, operating as in the AC bypass mode.

Operating Mode	Connection Status Between AC Output and AC Receptacle Earth
Inverter Mode (Battery input)	The AC Output-N pin, AC Receptacle Earth and FG are shorted internally
Bypass Mode (AC mains input)	The AC Receptacle Earth and FG are shorted internally. AC Output-L/N depends on AC mains input

■ IRC1/2/3 Remote Controller (Accessory sold separately)

- IRC1/IRC2/IRC3 is the monitoring and control unit.
- IRC1/IRC2/IRC3 can decode the RS-232 signals sent by the inverter series and display through digital meters.

Note: Part of the control signals will not function properly due to different compliance of each model.

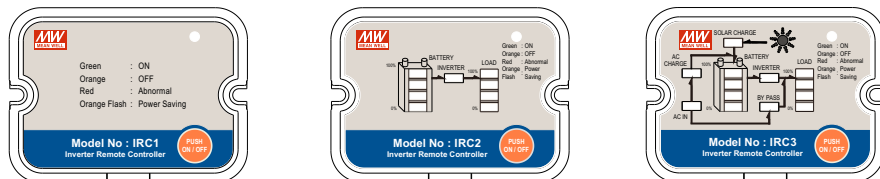

※ Please refer to for more detail: <https://www.meanwell.com/webapp/product/search.aspx?prod=IRC1>

■ Support RS-232 Communication

- The internal data of single NTU-2200 can read through RS-232.

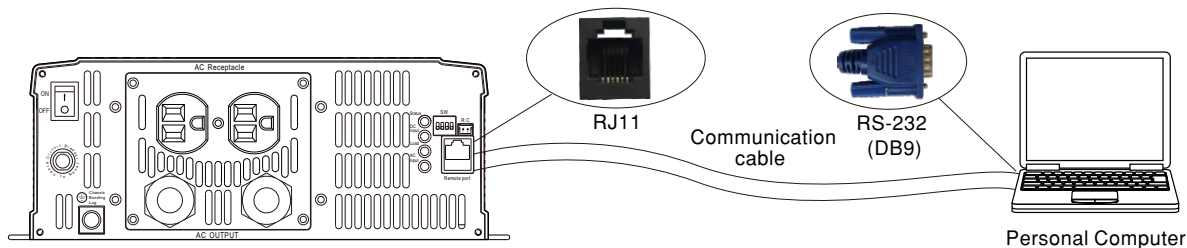

※ Please refer to for more detail: <http://www.meanwell.com/manual.html>

※ RJ11-RS232 Communication cable should be ordered separately, Order No.: RJ11-RS232

■ Remote ON-OFF Control (Built-in)

Remote ON-OFF	AC Output Status
Open	power inverter ON
Short	power inverter OFF

■ AC Output Voltage, Frequency, Power saving mode selectable by DIP SW

Output voltage and frequency setting factory settings are either 110Vac/60Hz or 230Vac/50Hz, users are able to adjust the voltage and frequency, through the DIP switch of position 1,2,3,4 on the panel.

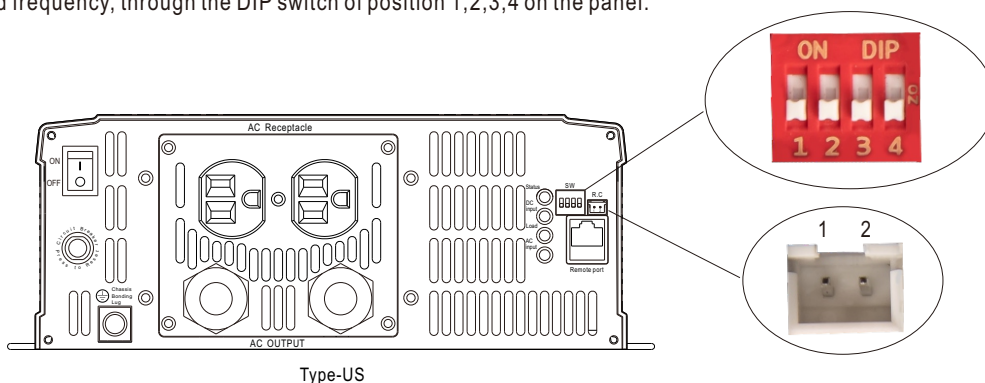

Type-US

AC Output Voltage, Frequency, Power saving mode selectable by DIP SW			
SW1	SW2	SW3	SW4
OFF	OFF : 100Vac or 200Vac	ON : 50Hz	ON : Saving mode
OFF	ON : 110Vac or 220Vac		
ON	OFF : 115Vac or 230Vac	OFF: 60Hz	OFF: Non-Saving mode
ON	ON : 120Vac or 240Vac		

■ LED STATUS

Normal work:

Status	Green	Orange	Red
	System check Inverter OK	Remote off Saving mode	Abnormal Status (See below table)

DC Input	Green	Orange	Red
	12.5~15.5Vdc 25~31Vdc 50~62Vdc	11~12.5Vdc 22~25Vdc 44~50Vdc	<11Vdc or >15.5Vdc <22Vdc or >31Vdc <44Vdc or >62Vdc

Mains Priority status:

Load	Green	Orange	Red
	<40% load	40~80% load	>80% load

Battery Priority status:

Load	Green	Orange	Red
	<40% load	40~80% load	>80% load

AC Input	Green	Orange	Red
	Mains OK Mains error Mains disconnected	-----	-----

Abnormal status :







LED Indicator	Abnormal Indication
Status DC Input Load	Output overload or AC output short circuit
Status DC Input Load	Abnormal DC voltage
Status DC Input Load	Over temperature or Fan lock
Status DC Input Load	Inverter fail

- Light
- Light off
- Flash



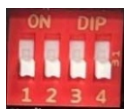





■ **FUNCTION MANUAL**

Battery /Mains Priority Setting (factory setting mains priority)

1. DIP S.W setting battery priority mode

Step	Action	Note
A1	When the power is not being sent, turn the 2 and 3 DIP switches of the selected DIP_SW to the "OFF" state	
A2	BAT power supply in remote off mode	
A3	Within 15 seconds of power transmission, switch 2 and 3 of the DIP_SW to full "ON", and then switch back to full "OFF"	 → 
A4	All LEDs (except AC input) flash green 3 times, indicating that the setting is successful	
A5	Turn off NTU and turn on the external Remote switch	 → 
A6	Turn on NTU to load battery priority mode	

2. DIP S.W setting mains priority mode

Step	Action	Note
A1	When the power is not being sent, turn the 2 and 3 DIP switches of the selected DIP_SW to the "ON" state	
A2	BAT power supply in remote off mode	
A3	Within 15 seconds of power transmission, switch 2 and 3 of the DIP_SW to full "OFF", and then switch back to full "ON"	 → 
A4	All LEDs (except AC input) flash green 3 times, indicating that the setting is successful <i>(Only clear battery priority mode, don't restore factory setting)</i>	
A5	Turn off NTU and turn on the external Remote switch	 → 
A6	Turn on NTU to load mains priority mode	

MECHANICAL SPECIFICATION

(Unit: mm, tolerance ± 1mm)

Case No. 289A

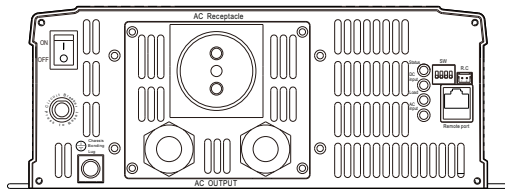
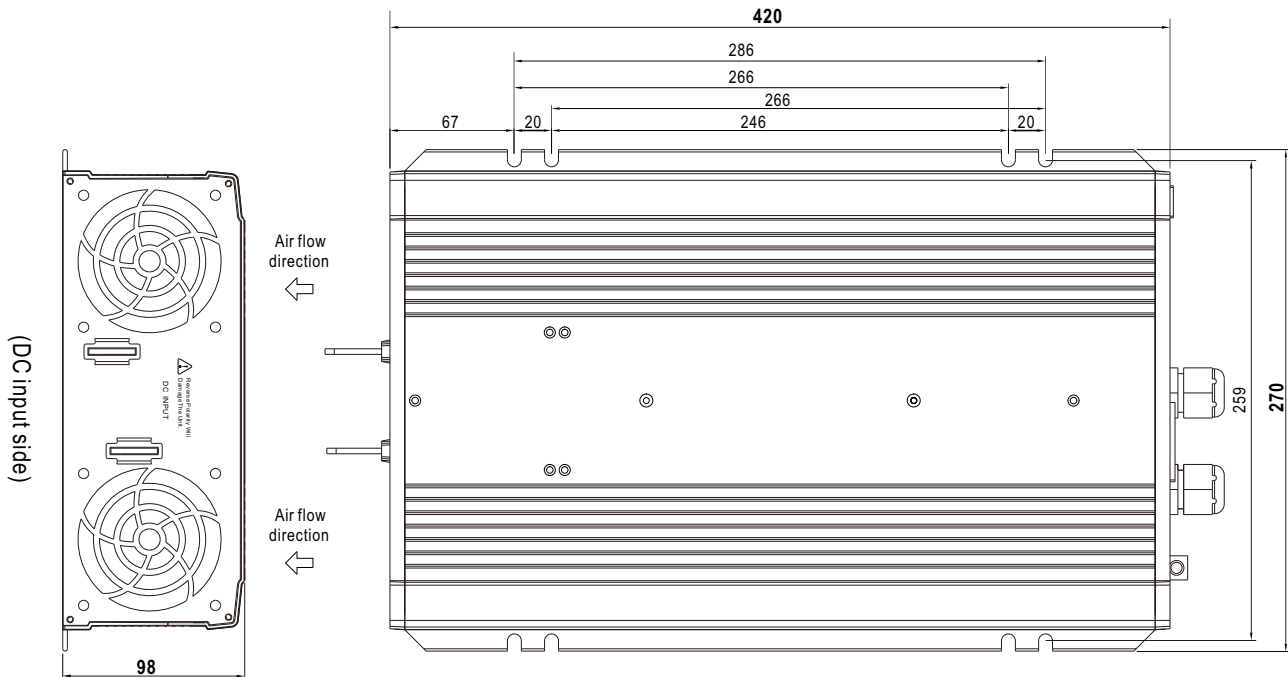

Type-EU

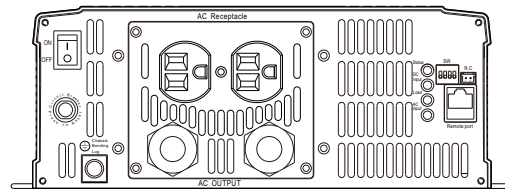

Type-US

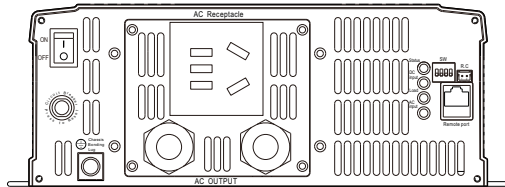

Type-CN

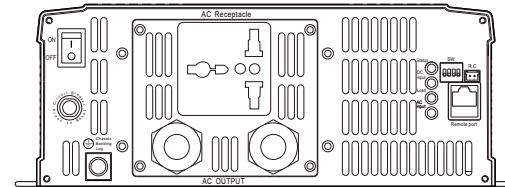

Type-UN

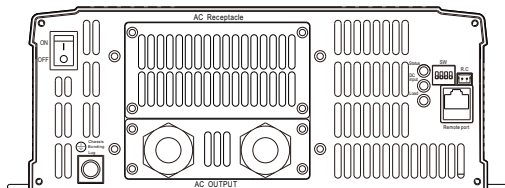

Type-TB

(AC output side)

R.C Connector : JST B-XH or equivalent

Remote Control	Mating Housing	Terminal
Pin 1,2 Open: Normal work	JST XHP or equivalent	JST SXH-001T or equivalent
Pin 1,2 Short: Remote off		

Remote port connector (RJ11)



Remote port

Assignment	Rx	GND	Tx
Remote port	2	3	4
DB9	3	5	2

Directions for use TB socket

Socket type	Withstand Current	Note
US	15A	When the load current is over withstand current, must use output terminal connection which can be found inside the AC output panel of the inverter.
EU	16A	
CN	10A	
UN	16A	
UK	13A	
AU	10A	

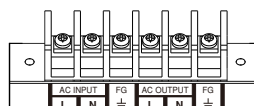



■ Accessory List

※ Communication cable (Optional accessory, Power inverter and Communication cable should ordered separately)

MW's Order No.	Item	Quantity
RJ11-RS232		1

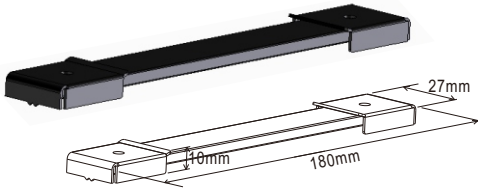
※ Carry handle (Optional accessory, Power inverter and Pull handle should ordered separately)

MW's Order No.	Item		Quantity
Carry Handle	①	Handle 	1
	②	Foot pad 	4
	③	Screw 	2



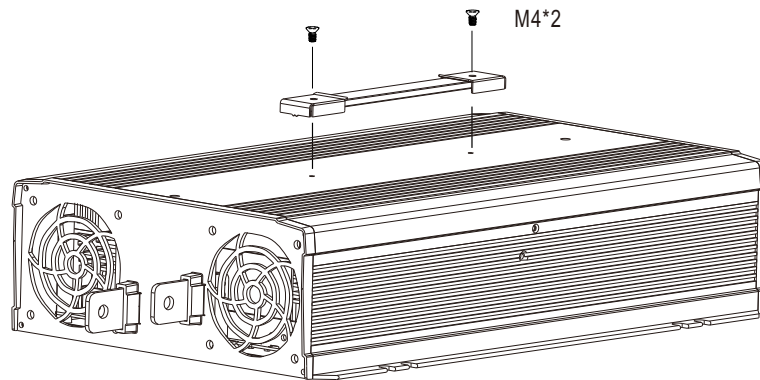

① Handle

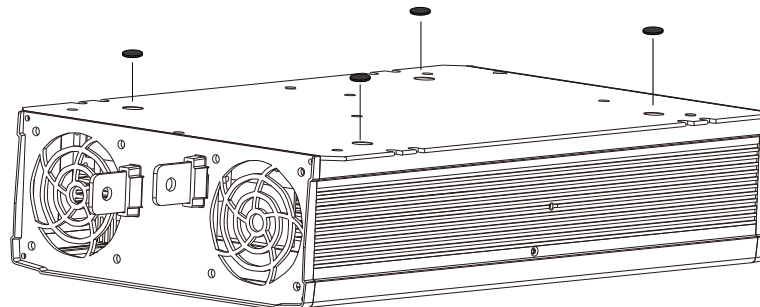

② Foot pad

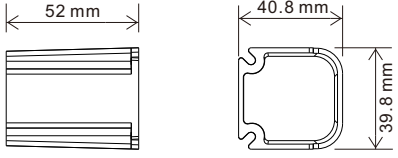

※ Terminal protector mating along with NTU-2200 (Standard accessory)

Item		Quantity
①	 	1
②	 	1
③		4

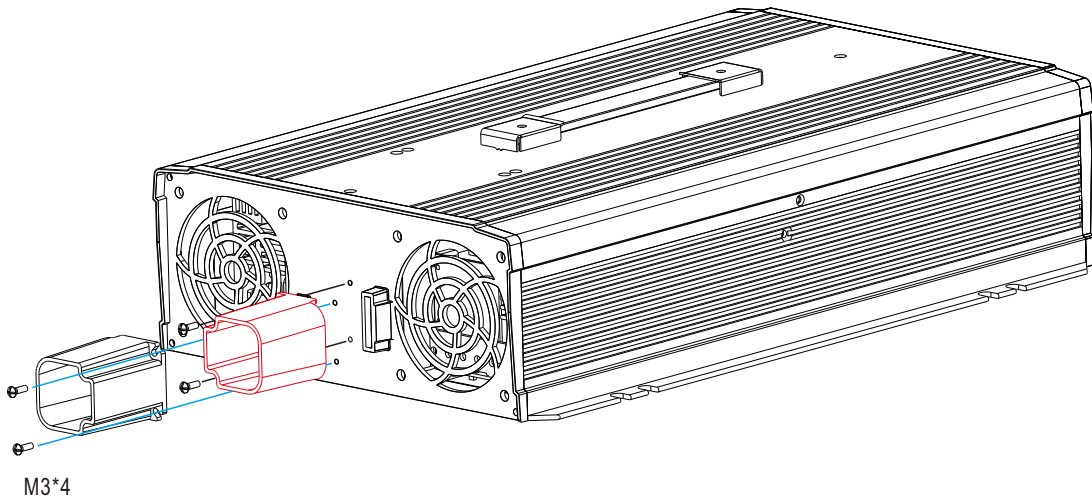

TYPICAL APPLICATION



- 1 Battery Bank
- 2 Off-Grid DC/AC Solar Inverter (NTS series)
- 3 AC Outlet



- 1 Utility Input (Shore)
- 2 AC/DC Battery Charger (PB/NPB/NPP series)
- 3 Battery Bank
- 4 Off-Grid AC/DC Power Inverter (NTS series)
- 5 AC Outlet

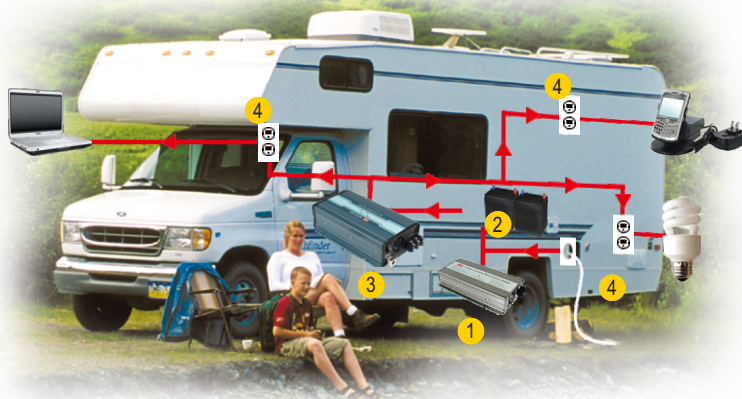

- 1 AC/DC Battery Charger (PB/NPB/NPP series)
- 2 Battery Bank
- 3 Off-Grid DC/AC Inverter (NTS series)
- 4 AC Outlet

INSTALLATION MANUAL

Please refer to : <http://www.meanwell.com/manual.html>

 www.simpex.ch

Besuchen Sie unseren Simpex E-Shop
mit über 12'000 Produkten.

Er bietet Ihnen eine breite Funktionsvielfalt, sowie intelligente
Suchfunktionen. Ob Sie den Shop als Einkaufsplattform oder als
Produktfinder nutzen – im Simpex E-Shop haben Sie alle Infor-
mationen schnell und tagesaktuell zur Hand.

24h und das 365 Tage im Jahr.



Hauptsitz

Simpex Electronic AG
Binzackerstrasse 33
CH-8620 Wetzikon
Telefon +41 44 931 10 10
E-Mail contact@simpex.ch
Internet www.simpex.ch