



16A AC Inrush Current Limiter

ICL-16R/16L



(ICL-16R)



(ICL-16L)



■ Features

- 23A inrush limiting current, 16A continuous
- 180~264VAC AC input
- Integrated bypass relay, no simple NTC
- Internal thermal protection
- Installed on DIN Rail TS-35/7.5 or 15 (ICL-16R)
- -30~+70°C wide working temperature
- 3 years warranty

■ Applications

- Allow connecting multiple power supply at same line
- Allows smaller and faster Circuit Breaker
- Capacitive load
- Protects against unintended trigger of Circuit Breaker

■ GTIN CODE

MW Search: <https://www.meanwell.com/serviceGTIN.aspx>

■ Description

The ICL-16 is a 16A inrush current limiter that can be used to reduce the high starting current due to capacitive load causing the circuit breaker to be false triggered. Several power supplies can be installed on the same AC line after the implementation of an ICL-16.

■ Model Encoding

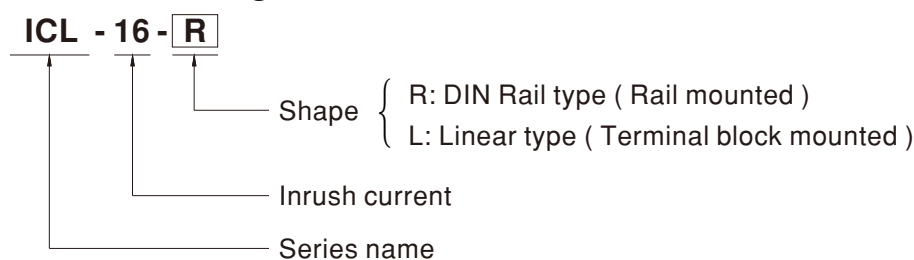



16A AC Inrush Current Limiter

ICL-16R/16L

SPECIFICATION

MODEL		ICL-16R	ICL-16L		
AC INPUT VOLTAGE		180 ~ 264VAC			
AC LINE FREQUENCY		47 ~ 63Hz			
INRUSH CURRENT LIMITING		23A			
AC CONTINUOUS RATED CURRENT		16A continuous			
AC INPUT POWER		3680VA (16A x 230VAC)			
AC INPUT CONSUMPTION		<1.5W at 264VAC,50Hz input			
INTERNAL RELAY LIMITING TIME (TON POWER ON)		300±50ms			
INTERNAL RELAY	LIMITING CYCLES	PSU Set up time<250ms 1 cycle / 5 min	PSU Set up time 250 ~ 350ms 1 cycle / 1 min	PSU Set up time >350ms 5 cycle / 1 min (>1500ms per cycle)	
	RELEASE TIME	500±50ms			
INTERNAL PROTECTION		Thermal fuse protects overload and fire			
ALLOWED CAPACITIVE LOAD		2500 μ F max.			
WORKING TEMP.		-30 ~ +70°C			
WORKING HUMIDITY		20 ~ 90% RH non-condensing			
STORAGE TEMP.		-40 ~ +85°C			
TEMP. COEFFICIENT		±0.03%/°C (0 ~ 50°C) RH non-condensing			
VIBRATION		10 ~ 500Hz, 2G 10min./1cycle, period for 60min. each along X, Y, Z axes; Mounting: Compliance to IEC60068-2-6			
OPERATING ALTITUDE (NOTE 2)		5000 meters			
OVER VOLTAGE CATEGORY		III; According to IEC62368-1; altitude up to 5000 meters			
POLLUTION DEGREE		2			
SAFETY STANDARDS		LVD BS EN/EN62368-1 approved			
SAFETY & EMC (Note.3)	EMC EMISSION	Parameter	Standard	Test Level / Note	
		Conducted	BS EN/EN55032	Class B	
		Radiated	BS EN/EN55032	Class B	
		Harmonic Current	BS EN/EN61000-3-2	Class A	
		Voltage Flicker	BS EN/EN61000-3-3	-----	
	EMC IMMUNITY	BS EN/EN55035,BS EN/EN61000-6-2			
		Parameter	Standard	Test Level /Note	
		ESD	BS EN/EN61000-4-2	Level 3, 8KV air; Level 2, 4KV contact, criteria A	
		Radiated Susceptibility	BS EN/EN61000-4-3	Level 3, criteria A	
		EFT/Burest	BS EN/EN61000-4-4	Level 3, criteria A	
		Surge	BS EN/EN61000-4-5	Level 4,2KV/L-N, criteria A	
		Conducted	BS EN/EN61000-4-6	Level 3, criteria A	
Magnetic Field		BS EN/EN61000-4-8	Level 4, criteria A		
Voltage Dips and interruptions	BS EN/EN61000-4-11	> 95% dip 0. 5 periods, 30% dip 25 periods, >95% interruptions 250 periods			
MTBF	7229.0K hrs min. Telcordia SR-332 (Bellcore) ; 2157.3K hrs min. MIL-HDBK-217F (25°C)		7217 .9K hrs min. Telcordia SR-332 (Bellcore) ; 2113 .8K hrs min. MIL-HDBK-217F (25°C)		
DIMENSION	35*90*54.5mm (L*W*H)		175*42*24mm (L*W*H)		
PACKING	0.116Kg; 96pcs/12.2Kg/1.04CUFT		0.132Kg; 98pcs/14Kg/1.04CUFT		
NOTE	<p>1. All parameters NOT specially mentioned are measured at 230VAC input, rated load and 25°C of ambient temperature.</p> <p>2. The ambient temperature derating of 3.5°C/1000m with fanless models and of 5°C/1000m with fan models for operating altitude higher than 2000m(6500ft).</p> <p>3. The power supply is considered as an independent unit, but the final equipment still need to re-confirm that the whole system complies with the EMC directives. For guidance on how to perform these EMC tests, please refer to "EMI testing of component power supplies." (as available on https://www.meanwell.com/Upload/PDF/EMI_statement_en.pdf)</p> <p>※ Product Liability Disclaimer : For detailed information, please refer to https://www.meanwell.com/serviceDisclaimer.aspx</p>				

■ BLOCK DIAGRAM

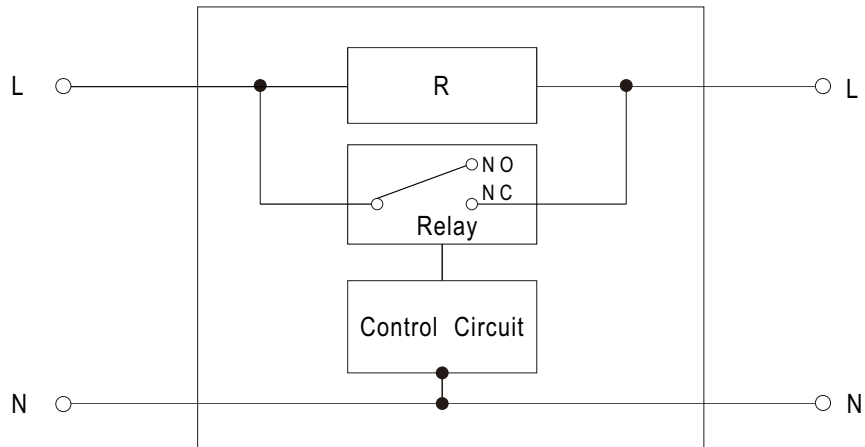

■ APPLICATION DIAGRAM

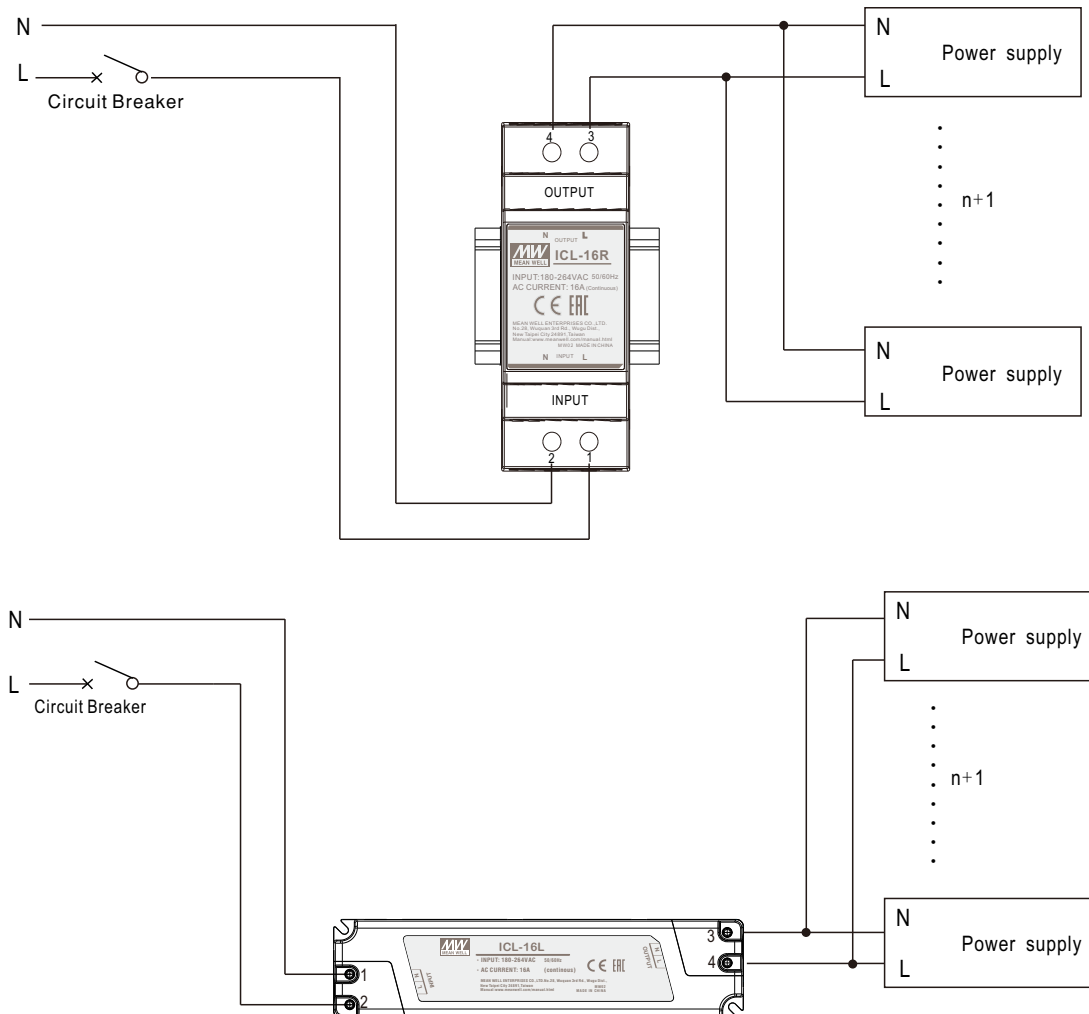

※ How many power supplies can be connected behind ICL-16R/ICL-16L?
Please refer to : <http://www.meanwell.com>.

MECHANICAL SPECIFICATION

- ICL-16R(DIN Rail type)
(Unit: mm , tolerance ± 1 mm)

Case No.ICL-16R

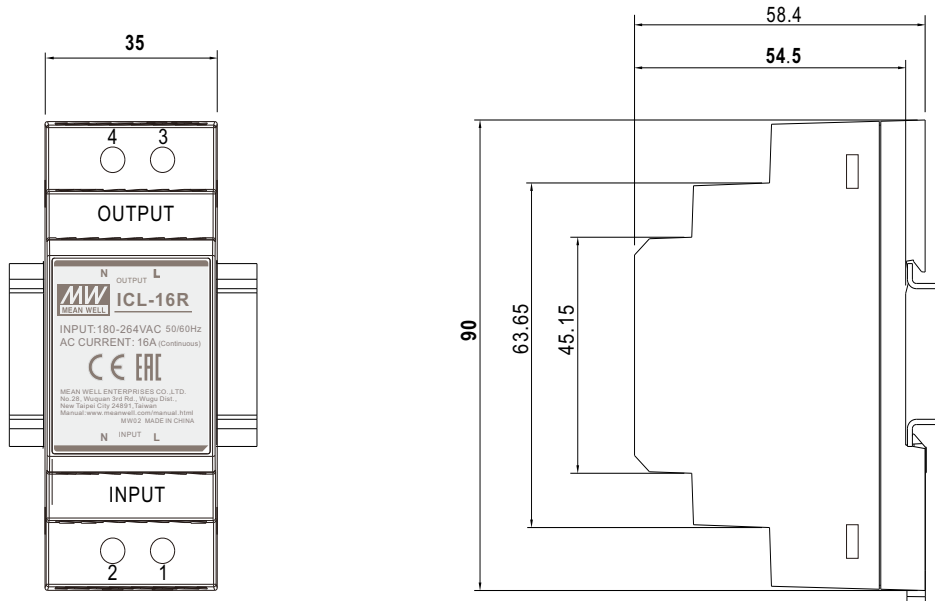

Terminal Pin No. Assignment

Pin No.	Assignment	Pin No.	Assignment
1	AC/L Input	3	AC/L Output
2	AC/N Input	4	AC/N Output

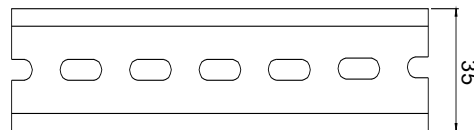

ADMISSIBLE DIN-RAIL:TS35/7.5 OR TS35/15

- ICL-16L(Linear type)
(Unit: mm , tolerance ± 1 mm)

Case No.PLM-40

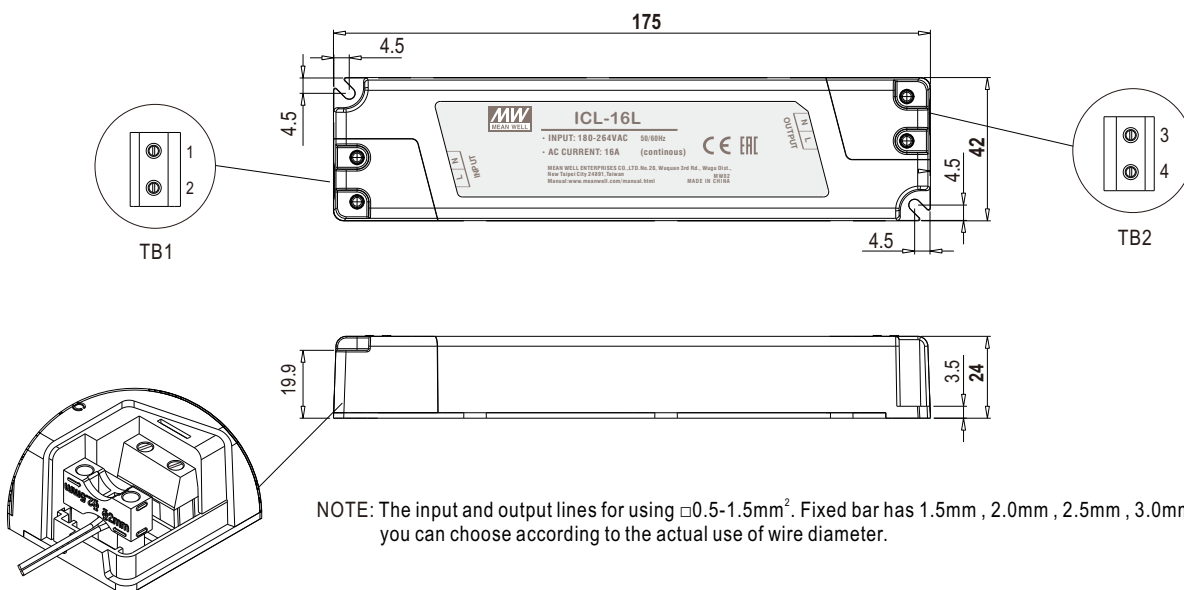

NOTE: The input and output lines for using $\square 0.5-1.5\text{mm}^2$. Fixed bar has 1.5mm , 2.0mm , 2.5mm , 3.0mm four grooves, you can choose according to the actual use of wire diameter.

Terminal Pin No. Assignment (TB1,TB2)
SWITHLAB MB312-750 equivalent

Pin No.	Assignment	Pin No.	Assignment
1	AC/N Input	3	AC/N Input
2	AC/L Input	4	AC/L Input

 www.simpex.ch

Besuchen Sie unseren Simpex E-Shop
mit über 12'000 Produkten.

Er bietet Ihnen eine breite Funktionsvielfalt, sowie intelligente
Suchfunktionen. Ob Sie den Shop als Einkaufsplattform oder als
Produktfinder nutzen – im Simpex E-Shop haben Sie alle Infor-
mationen schnell und tagesaktuell zur Hand.

24h und das 365 Tage im Jahr.



Hauptsitz

Simpex Electronic AG
Binzackerstrasse 33
CH-8620 Wetzikon
Telefon +41 44 931 10 10
E-Mail contact@simpex.ch
Internet www.simpex.ch