



CFM300S Series

Application Note V12 August 2020

300W AC-DC Power Supply with PFC CFM300S Series APPLICATION NOTE



Approved By:

Department	Approved By	Checked By	Written By
Research and Development Department	Enoch	Yang	Wei-Cheng
		Ovid	
Quality Assurance Department	Ryan	Benny	



CFM300S Series

Application Note V12 August 2020

Content

1. INTRODUCTION	3
2. CFM300S SERIES CONVERTER FEATURES	3
3. ELECTRICAL BLOCK DIAGRAM	3
4. TECHNICAL SPECIFICATIONS	4
5. MAIN FEATURES AND FUNCTIONS	7
5.1 <i>Operating Temperature Range</i>	7
5.2 <i>Output Protection (Over Current Protection)</i>	7
6. EMC & SAFETY	7
7. APPLICATIONS	7
7.1 <i>Power De-Rating Curve</i>	7
7.2 <i>Test Set-Up</i>	8
7.3 <i>Output Ripple and Noise Measurement</i>	8
7.4 <i>Installation Instruction</i>	8
7.5 <i>PS On/Off Remote Control</i>	10
7.6 <i>Output Remote Sensing</i>	11
8. PART NUMBER	11
9. MECHANICAL OUTLINE DIAGRAMS AND PACKING INFORMATION	12
9.1 <i>Mechanical Outline Diagrams</i>	12
9.2 <i>Packing Information</i>	13



CFM300S Series

Application Note V12 August 2020

1. Introduction

This application note describes the features and functions of Cincon's CFM300S series of open frame, switching AC-DC power module. These are highly efficient, reliable, compact, high power density, single output AC/DC power modules. The module is fully protected against short circuit and over-voltage conditions. Cincon's world class automated manufacturing methods, together with an extensive testing and qualification program, ensure that the CFM300S series power module is extremely reliable.

2. CFM300S Series Features

- Universal Input Range 90~264Vac
- Active PFC Meets EN61000-3-2 Class C&D
- High Efficiency up to 94%
- High Power Density up to 14.1W/Inch³
- Over Temperature Protection
- Continuous Short Circuit Protection
- Remote Voltage Sense
- PS On/Off Remote Control
- Power Good & Power Fail Signal
- +5V Stand-by Output Power
- 12V Fan Output
- No Load Power Consumption<0.3W
- 3"x 5" Size
- Meets EN55032 and EN55022 Class B
- IEC/EN/UL 62368-1 Approval
- Meets IEC/EN 60335-1
- Meets Class I

3. Electrical Block Diagram

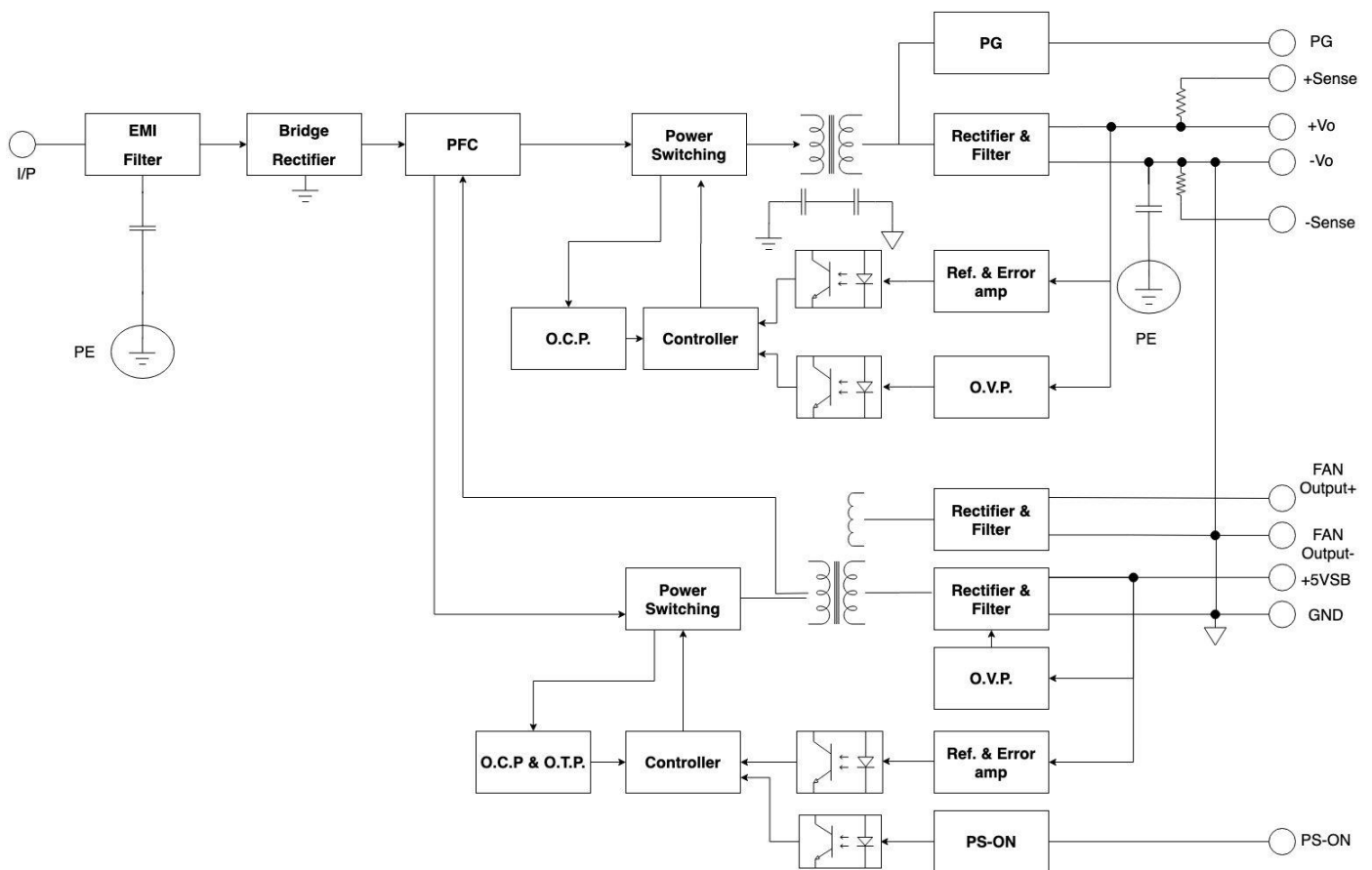



CFM300S Series

Application Note V12 August 2020

4. Technical Specifications

(All specifications are typical at nominal input, full load at 25°C unless otherwise noted.)

ABSOLUTE MAXIMUM RATINGS						
PARAMETER	NOTES and CONDITIONS	Device	Min.	Typical	Max.	Units
Input Voltage (Continuous)		All	90		264	Vac
			120		370	Vdc
Operating Temperature	See derating curve	All	-40		+80	°C
Storage Temperature		All	-40		+85	°C
INPUT CHARACTERISTICS						
PARAMETER	NOTES and CONDITIONS	Device	Min.	Typical	Max.	Units
Operating Voltage Range		All	100		240	Vac
Input Frequency Range		All	47		63	Hz
Maximum Input Current	100% Load, Vin=100Vac	All			4	A
Leakage Current		All			3.5	mA
Inrush Current	Vin=240Vac, cold start at 25°C.	All			30	A
OUTPUT CHARACTERISTICS						
PARAMETER	NOTES and CONDITIONS	Device	Min.	Typical	Max.	Units
Output Voltage Set Point	Vin=Nominal Vin, Io=Io .max, Tc=25°C.	CFM300S120/120C	11.4	12	12.6	Vdc
		CFM300S240/240C	22.8	24	25.2	
		CFM300S360/360C	34.2	36	37.8	
		CFM300S480/480C	45.6	48	50.4	
Operating Output Current Range		CFM300S120/120C			25	A
		CFM300S240/240C			12.5	
		CFM300S360/360C			8.34	
		CFM300S480/480C			6.25	
Holdup Time	Vin=115Vac(typ.)	All		20		ms
Output Voltage Regulation						
Load Regulation	10% load to full load	All			±1.0	%
Line Regulation	Vin=high line to low line	All			±0.5	%
Over Current Protection	Hiccup mode(Auto Recovery)	All	130	150	180	%
Over Voltage Protection	Latch mode	CFM300S120/120C		15		Vdc
		CFM300S240/240C		30		
		CFM300S360/360C		43		
		CFM300S480/480C		56		
Over Temperature Protection	The temperature of C37(Auto Recovery)	All			110	°C
Output Ripple and Noise	1. Add a 0.1uF ceramic capacitor and a 10uF aluminum electrolytic capacitor to output. 2. Oscilloscope is 20MHz band width. 3. Ambient temperature=25°C	CFM300S120/120C			120	mVp-p
		CFM300S240/240C			150	
		CFM300S360/360C			150	
		CFM300S480/480C			150	
Load Capacitance	1. Input voltage is 115VAC and 230VAC 2. Output is max. load	CFM300S120/120C			25000	uF
		CFM300S240/240C			12500	
		CFM300S360/360C			5000	
		CFM300S480/480C			3750	



CFM300S Series

Application Note V12 August 2020

PARAMETER	NOTES and CONDITIONS	Device	Min.	Typical	Max.	Units
Efficiency	1. Input voltage is 230VAC 2. Output is max. load	CFM300S120/120C CFM300S240/240C CFM300S360/360C CFM300S480/480C		92.5 93.5 93.5 94.0		%
PS-On Signal (see chapter 7.5)	Power on	All	0		2	Vdc
	Power off(PS-ON and GND open)		11		16	
	Power on (PS-ON and GND short)			Source Current 4.5		mA
	Power-off(PS-ON and GND open)			0		
Power Good(PG)	1. Input voltage is 90VAC~264VAC 2. Output is max. load 3. The TTL goes high after power set up	All	50		250	ms
Power Fail(PG)	1. Input voltage is 90VAC~264VAC 2. Output is max. load 3. The TTL goes low before Vo below 90% rated value	All	5		20	ms

ISOLATION CHARACTERISTICS

PARAMETER	NOTES and CONDITIONS	Device	Min.	Typical	Max.	Units
Input to Output	1 minute	All			3000	Vac
Input to Earth	1 minute	All			1500	Vac
Output to Earth	1 minute	All			500	Vac
Isolation Resistance		All	100			MΩ

FEATURE CHARACTERISTICS

PARAMETER	NOTES and CONDITIONS	Device	Min.	Typical	Max.	Units
Switching Frequency	Pout=max. rated power	All		70		KHz
Output Voltage adjustment	Pout=max. rated power	All	-5		+5	%



CFM300S Series

Application Note V12 August 2020

GENERAL SPECIFICATIONS						
PARAMETER	NOTES and CONDITIONS	Device	Min.	Typical	Max.	Units
Humidity	Non-condensing	All			93	% RH
Shock	Meets MIL-STD-810F Table 516.5, TABLE 516.5-1 10ms, each axis 3 times(+X · Y · Z axis)	All		75		g
Vibration	Meets MIL-STD-810F Table 514.5C-VIII, 15 ~ 2000Hz, X · Y · Z axis ,1 hr(each axis),. total 3 hrs.	All		4		g
MTBF	Io=100%; Ta=25°C per MIL-HDBK-217F	All		160		K hours
Weight		CFM300SXXX CFM300SXXXC		420 550		g
Safety	Class I, IEC/EN/UL 62368-1					
EMC Emission	EN55032, EN55022, EN61000-3-2, EN61000-3-3, FCC CFR 47 Part 15 Subpart B					
Conducted disturbance at main terminal	EN55032:2012+AC:2013, EN55022:2010+AC2011, Class B, FCC CFR 47 Part 15 Subpart B					
Radiated disturbance	EN55032:2012+AC:2013, EN55022:2010+AC2011, Class B, FCC CFR 47 Part 15 Subpart B					
Harmonic current emissions	IEC 61000-3-2:2014, Class C & D					
Voltage fluctuations & flicker	IEC 61000-3-3:2013					
EMC Immunity	IEC61000-4-2,3,4,5,6,8,11					
Electrostatic discharge (ESD)	IEC 61000-4-2:2008, ±2kv, ±4kv, Criteria A					
Radio-frequency, Continuous radiated disturbance	IEC 61000-4-3:2010, Criteria A					
Electrical fast transient (EFT)	IEC 61000-4-4:2012, ±0.5kv, ±1kv, ±2kv, Criteria A					
Surge	IEC 61000-4-5:2005, L-N: ±0.5kv, ±1kv, L-PE, N-PE: ±0.5kv, ±1kv, ±2kv, Criteria A					
Conducted disturbances, induced by RF fields	IEC 61000-4-6:2013, Criteria A					
Power frequency magnetic field	IEC 61000-4-8:2009, Criteria A					
Voltage dips	IEC 61000-4-11: 2004, Dip: 30% reduction, Dip: 70% reduction, Criteria A					
Voltage interruptions	IEC 61000-4-11:2004, >95% reduction, Criteria B					



CFM300S Series

Application Note V12 August 2020

5. Main Features and Functions

5.1 Operating Temperature Range

The highly efficient design of Cincon's CFM300S series power modules has resulted in their ability to operate within ambient temperature environments from -40°C to 80°C . Due consideration must be given to the de-rating curves when ascertaining the maximum power that can be drawn from the module. The maximum power which can be drawn is influenced by a number of factors, such as

- Input voltage range
- Permissible Output load (per derating curve)
- Effective heat sinks

5.2 Output Protection (Over Current Protection)

The power modules provide full continuous short-circuit protection. The unit will auto recover once the short circuit is removed. To provide protection in a fault condition, the unit is equipped with internal over-current protection. The unit will operate normally once the fault condition is removed. The power module will go to hiccup mode if the output current is set from 130% to 180% of rated current.

6. EMC & Safety

■ Emission and Immunity

EN55032, EN55022, EN61000-3-2, EN61000-3-3, FCC CFR 47 Part 15 Subpart B, IEC61000-4-2, IEC61000-4-3, IEC61000-4-4, IEC61000-4-5, IEC61000-4-6, IEC61000-4-8, IEC61000-4-11

■ Safety

Class I, IEC/EN/UL 62368-1

7. Applications

7.1 Power De-Rating Curve

CFM300S Series Derating Curve

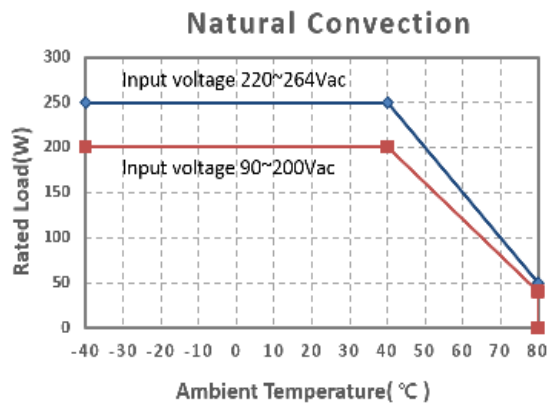
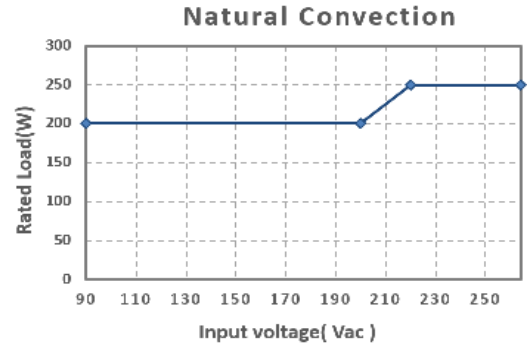
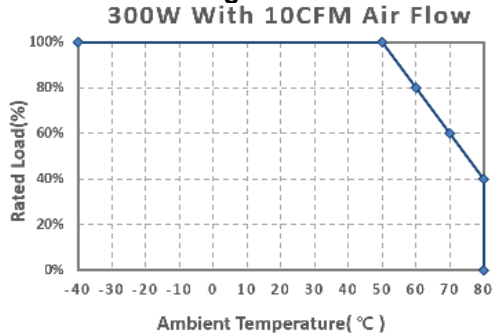

CFM300SXXXC Series Derating Curve

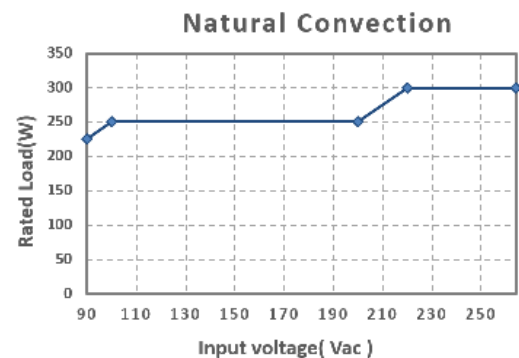
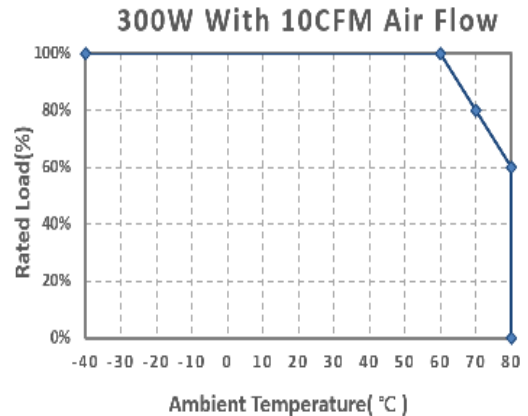



CFM300S Series

Application Note V12 August 2020

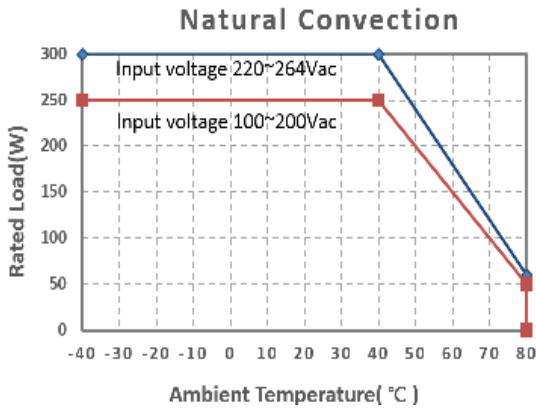

7.2 Test Set-Up

The basic test set-up to measure parameters such as efficiency and load regulation is shown in Figure 1. When testing the Cincon's CFM300S series under any transient conditions, please ensure that the transient response of the source is sufficient to power the equipment under test. We can calculate the

- Efficiency
- Load regulation and line regulation.

The value of efficiency is defined as:

$$\eta = \frac{V_o \times I_o}{P_{in}} \times 100\%$$

Where:

- V_o is output voltage
- I_o is output current
- P_{in} is input power

The value of load regulation is defined as:

$$\text{Load reg.} = \frac{V_{FL} - V_{NL}}{V_{NL}} \times 100\%$$

Where:

- V_{FL} is the output voltage at full load
- V_{NL} is the output voltage at 10% load

The value of line regulation is defined as:

$$\text{Line reg.} = \frac{V_{HL} - V_{LL}}{V_{LL}} \times 100\%$$

Where:

- V_{HL} is the output voltage of maximum input voltage at full load.
- V_{LL} is the output voltage of minimum input voltage at full load.

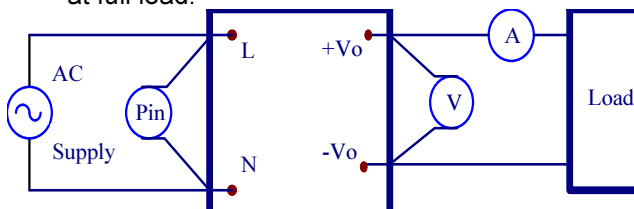

Figure 1. CFM300S Series Test Setup

7.3 Output Ripple and Noise Measurement

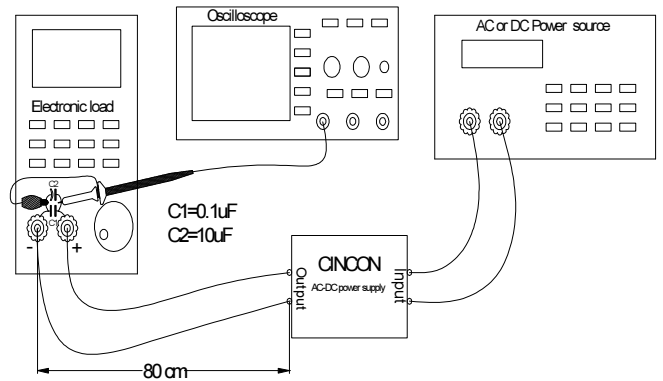
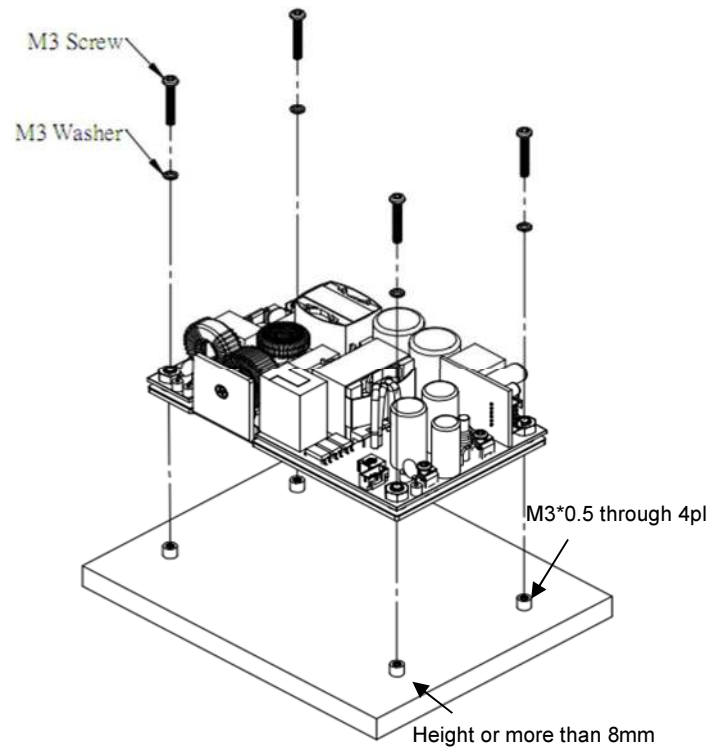

Figure 2. Output Voltage Ripple and Noise Measurement Set-Up

7.4 Installation Instruction

The CFM300S & CFM300SXXXC series has four 4mm diameter mounting holes. There are three type installations for CFM300S & CFM300SXXXC. Please use the mounting holes as follows:

Insert the spacer (4mm diameter max.) of 8mm height or more to mount the unit. The vibration specification applies when the unit is mounted on 8mm spacers





CFM300S Series

Application Note V12 August 2020

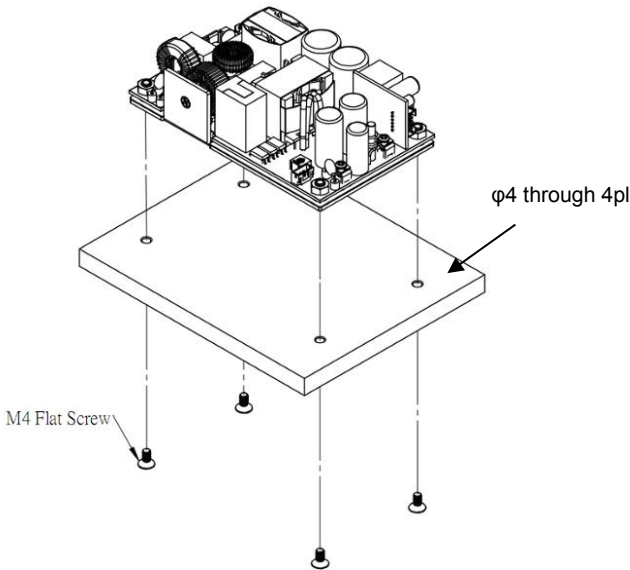
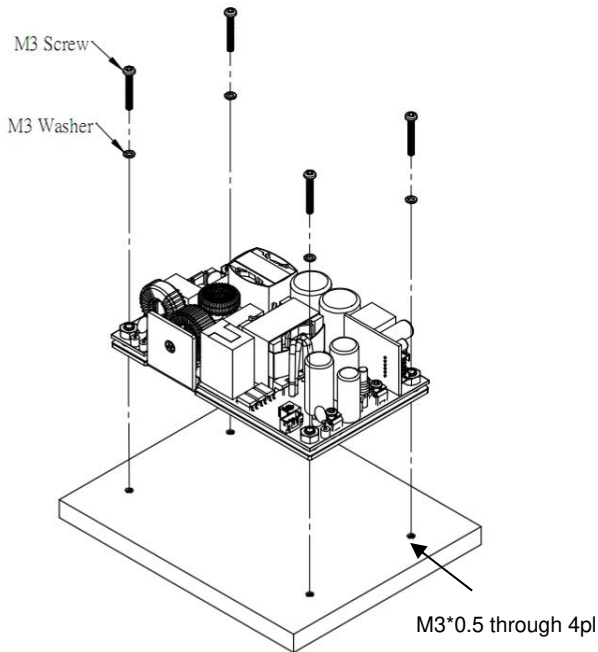

The torque of output connectors are 3kgf-cm and the connectors mate with round or Y terminal. The maximum outer diameter of the terminals are 6.75mm and the maximum inner diameter are 3.9mm. When locking the round terminal or Y terminal to output connectors, the terminals should not touch other parts to avoid short.

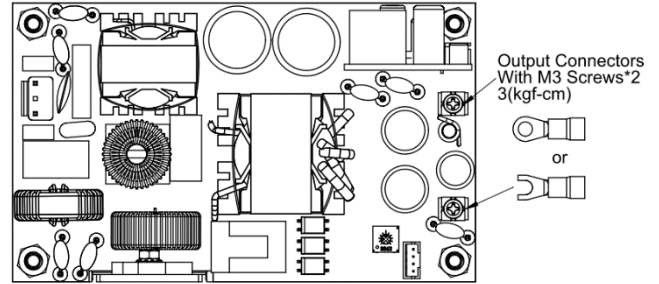

Please allow 4mm side clearance from the components and all side of the PCB. Allow 5mm clearance above the highest parts on the PCB. Be especially careful to allow 8mm between the solder side of the PCB and the mounting surface. If the clearances are not sufficient, the specifications for isolation and withstand will not be valid.

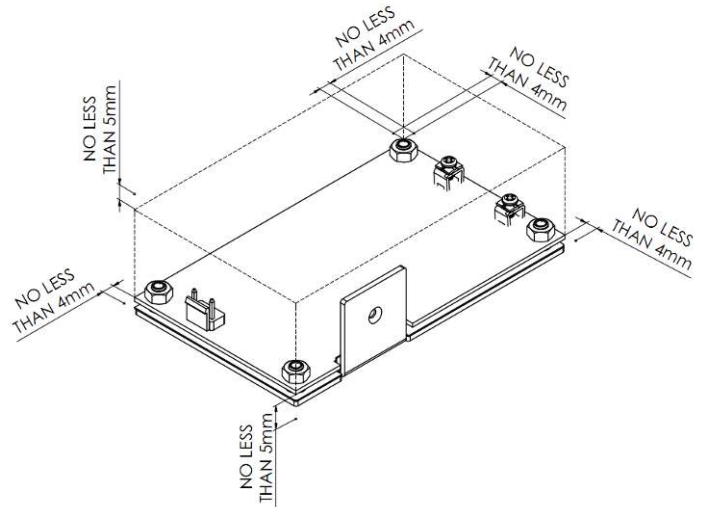

The torque of CFM300S & CFM300SXXXC as follows:

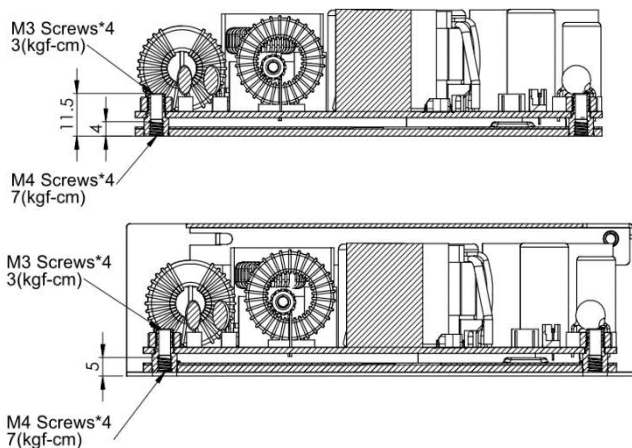

FG should be connected to the earth (ground) terminal of the apparatus. If not, the conducted noise and output noise will increase.

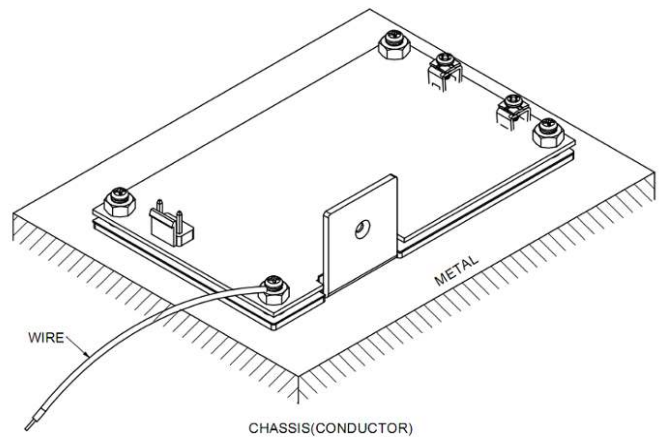



CFM300S Series

Application Note V12 August 2020

7.5. PS On/Off Remote Control

A PS On/Off remote control is provided in CN4. The PS-ON diagram and control function is shown as follow.

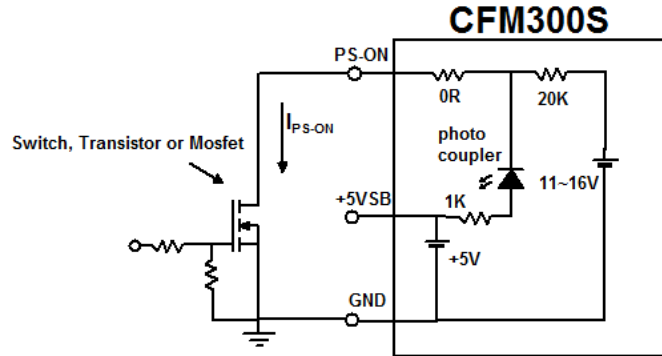

Power On: $V_{PS-ON} \leq 2V$, $I_{PS-ON} \geq 2mA$
 (PS-ON and GND short, $I_{PS-ON} = 4.5 mA$ typical)

Power Off: Open circuit, $V_{PS-ON} = 11 \sim 16V$

When the PS On/Off remote control function is not used, connect a short circuit between the PS-ON control and the signal GND

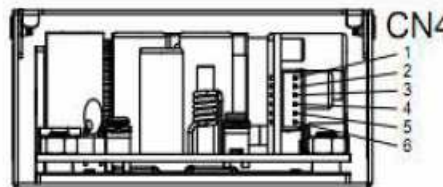
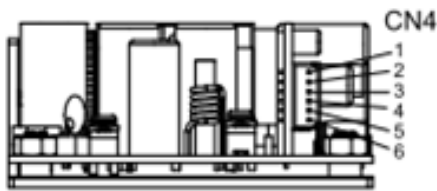
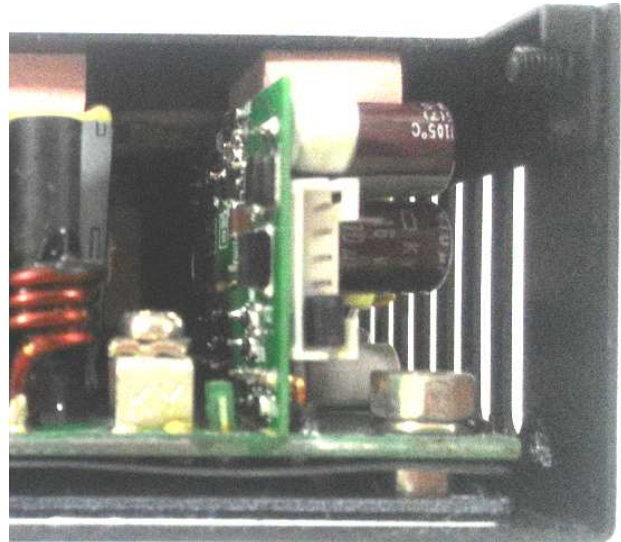
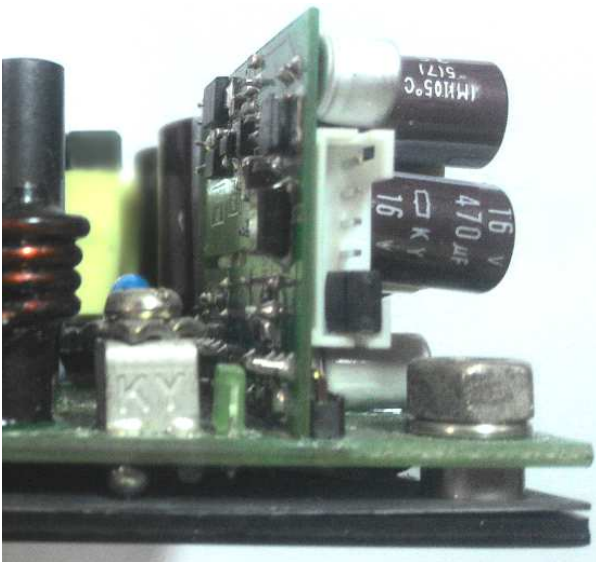

CN4:
PIN CONNECTION

Pin	Function
1	FAN Output-
2	FAN Output+
3	GND
4	+5VSB
5	GND
6	PS-ON



CFM300S Series

Application Note V12 August 2020

7.6. Output Remote Sensing

The CFM300S SERIES converter has the capability to remotely sense both lines of its output. This feature moves the effective output voltage regulation point from the output of the unit to the point of connection of the remote sense pins. This feature automatically adjusts the real output voltage of the CFM300S series in order to compensate for voltage drops in distribution and maintain a regulated voltage at the point of load. The remote-sense voltage range is:

$$[(+V_{out}) - (-V_{out})] - [(+Sense) - (-Sense)] \leq 5\% \text{ of } V_{o_nominal}$$

If the remote sense feature is not to be used, the sense pins should be connected locally. The +Sense pin should be connected to the +Vout pin at the module and the -Sense pin should be connected to the -Vout pin at the module. A Remote Sensing is provided in CN4

This is shown in the schematic below.

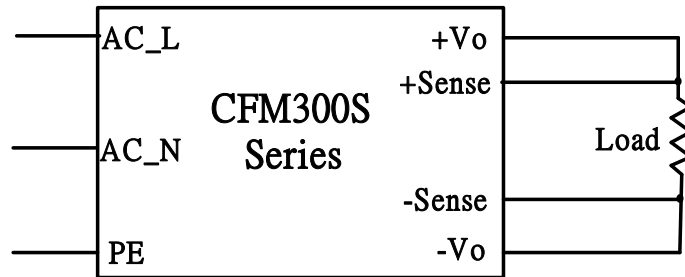

8. Part Number

CFM 300 S XXX C

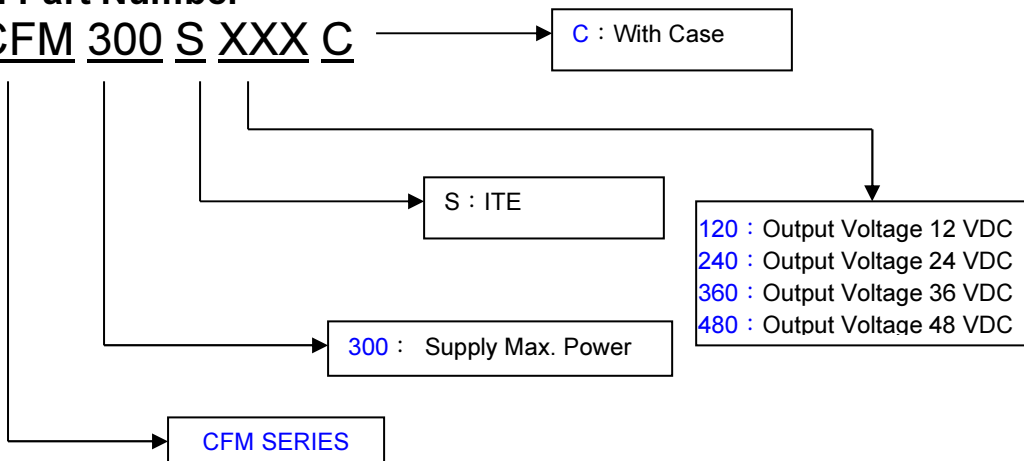



CFM300S Series

Application Note V12 August 2020

9. Mechanical Outline Diagrams and Packing Information

9.1. Mechanical Outline Diagrams

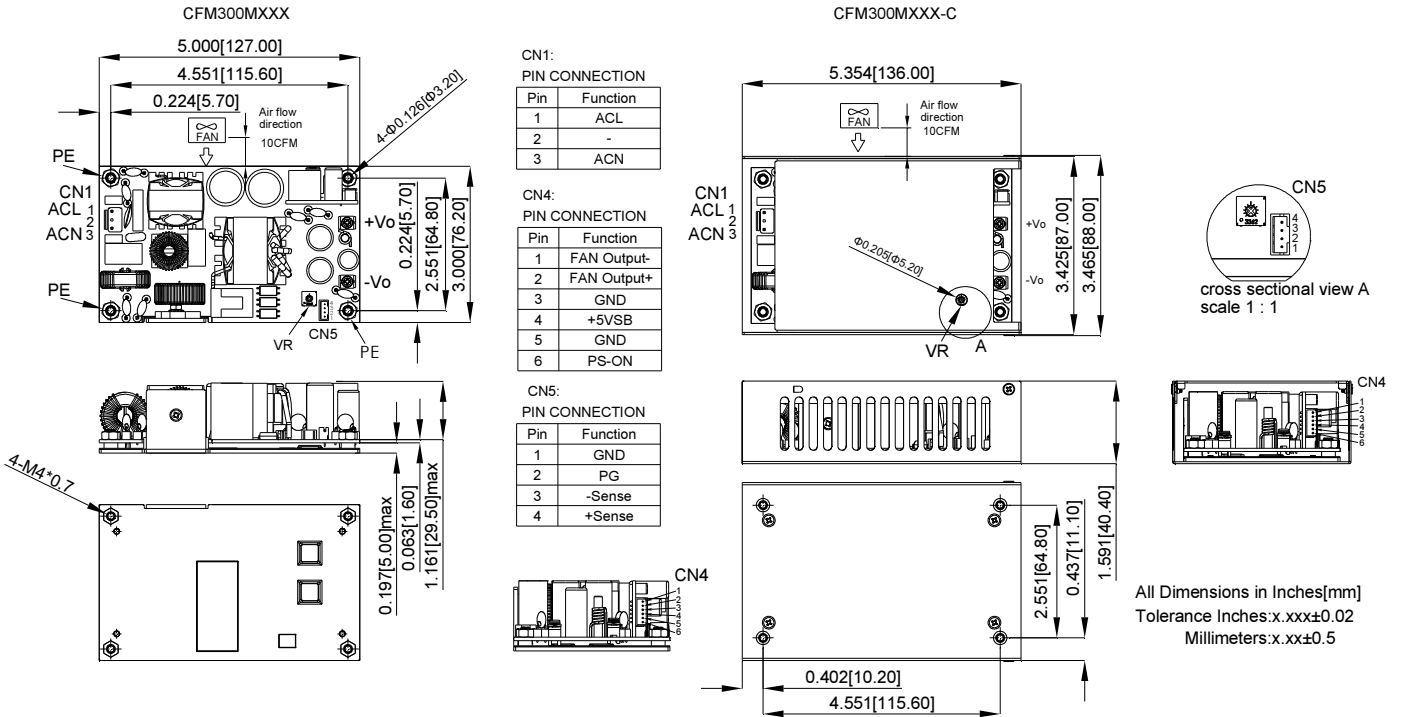

Figure 3. CFM300S series Mechanical Outline Diagram



CFM300S Series

Application Note V12 August 2020

9.2. Packing Information

The packing information for CFM300 SERIES is showing as follows:

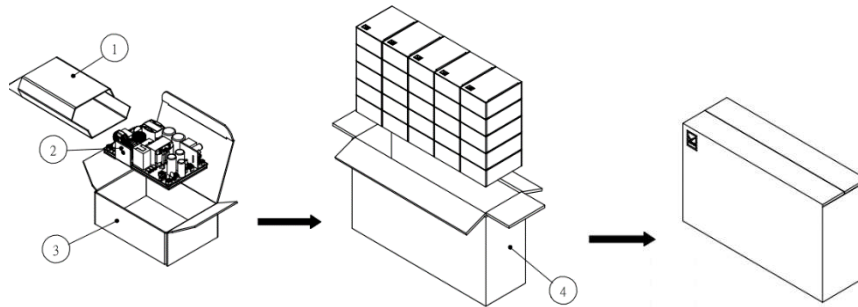

ITEM	PART NO.	NAME	OUTSIDE DIM	PCS
1	G64F00005	Anti-static bubble bags	(110+60)*165mm	25
2		CFM300M/S	127*76.2*35mm	25
3	G64205245	Carton	140*100*55mm	25
4	G64112330	Carton box	525*155*300mm	1

CFM300M/S 25PCS a box, including the total weight of package material about 11Kg

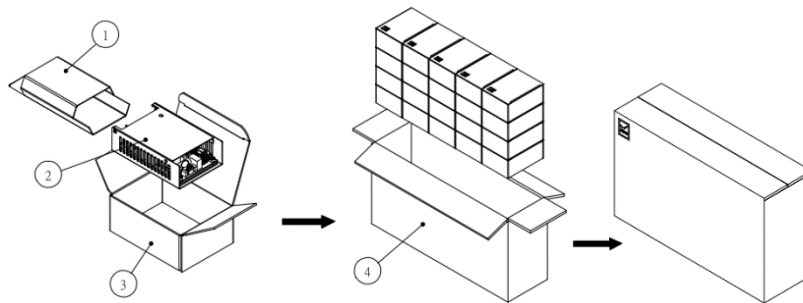

ITEM	PART NO.	NAME	OUTSIDE DIM	PCS
1	G64F00007	Anti-static bubble bags	(230+80)*150mm	20
2		CFM300M-C/S-C	136*87*40.4mm	20
3	G64205247	Carton	145*105*65mm	20
4	G64112331	Carton box	550*160*285mm	1

CFM300M-C/S-C 20PCS a box, including the total weight of package material about 12Kg

Headquarters:

14F, No.306, Sec.4, Hsin Yi Rd.
 Taipei, Taiwan
 Tel: 886-2-27086210
 Fax: 886-2-27029852
 E-mail: sales@cincon.com.tw
 Web Site: <https://www.cincon.com>

CINCON ELECTRONICS CO., LTD.

Factory:

No. 8-1, Fu Kung Rd.
 Fu Hsing Industrial Park
 Fu Hsing Hsiang,
 Chang Hua Hsien, Taiwan
 Tel: 886-4-7690261
 Fax: 886-4-7698031

Cincon North America:

1655 Mesa Verde Ave. Ste 180
 Ventura, CA 93003
 Tel: 805-639-3350
 Fax: 805-639-4101
 E-mail: info@cincon.com