



# ECLB75W 75 Watt Isolated DC-DC Converters

## Application Note V10 July 2019

### ISOLATED DC-DC CONVERTER ECLB75W SERIES APPLICATION NOTE



**Approved By:**

Department	Approved By	Checked By	Written By
Research and Development Department	Enoch	Astray	James
		Jacky	
Quality Assurance Department	Ryan	Benny	



### Content

<b>1. INTRODUCTION</b>	<b>3</b>
<b>2. DC-DC CONVERTER FEATURES</b>	<b>3</b>
<b>3. ELECTRICAL BLOCK DIAGRAM</b>	<b>3</b>
<b>4. TECHNICAL SPECIFICATIONS</b>	<b>5</b>
<b>5. MAIN FEATURES AND FUNCTIONS</b>	<b>9</b>
5.1 Operating Temperature Range	9
5.2 Remote On/Off	9
5.3 UVLO (Under Voltage Lock Out)	9
5.4 Over Current Protection	9
5.5 Over Voltage Protection	9
5.6 Over-Temperature Protection (OTP)	9
5.7 Output Voltage Adjustment	10
<b>6. APPLICATIONS</b>	<b>10</b>
6.1 Recommended Layout PCB Footprints and Soldering Information	10
6.2 Connection for standard use	10
6.3 Input Capacitance at the Power Module	11
6.4 Convection Requirements for Cooling	11
6.5 Thermal Considerations	11
6.6 Power De-Rating Curves for ECLB75W Series	12
6.7 LB Heat Sinks	15
6.8 Efficiency vs. Load Curves	16
6.9 Test Set-Up	18
6.10 Output Voltage Adjustment	18
6.12 Output Ripple and Noise	20
6.13 Output Capacitance	20
6.14 Remote On/Off Circuit	21
<b>7. SAFETY &amp; EMC</b>	<b>22</b>
7.1 Input Fusing and Safety Considerations.	22
7.2 EMC Considerations	22
<b>8. PART NUMBER</b>	<b>28</b>
<b>9. MECHANICAL SPECIFICATIONS</b>	<b>28</b>



# ECLB75W 75 Watt Isolated DC-DC Converters

## Application Note V10 July 2019

### 1. Introduction

The ECLB75W series of DC-DC converters offers 75 watts of output power single and dual output voltages of 5, 12, 15,  $\pm 12$ ,  $\pm 15$ ,  $\pm 24$ VDC with standard 2"X1" pin out. It has a wide (4:1) input voltage range of 9 to 36VDC (24VDC nominal) and 18 to 75VDC (48VDC nominal). Apart from, it has 2250VDC isolation (input to output).

Compliant with EN55022, EN55032. High efficiency up to 92.5%, allowing case operating temperature range of  $-40^{\circ}\text{C}$  to  $105^{\circ}\text{C}$ . An optional heat sink is available to extend the full power range of the unit. Very low no load power consumption, an ideal solution for energy critical systems.

The standard control functions include remote on/off (positive or negative) and +10%, -20% adjustable output voltage.

Fully protected against input UVLO (under voltage lock out), output over-current, output over-voltage and over-temperature and continuous short circuit conditions.

ECLB75W series is designed primarily for common applications of 12V, 24V, 48V nominal voltage and also suitable for distributed power architectures, telecommunications, battery operated equipment and industrial applications.

### 3. Electrical Block Diagram

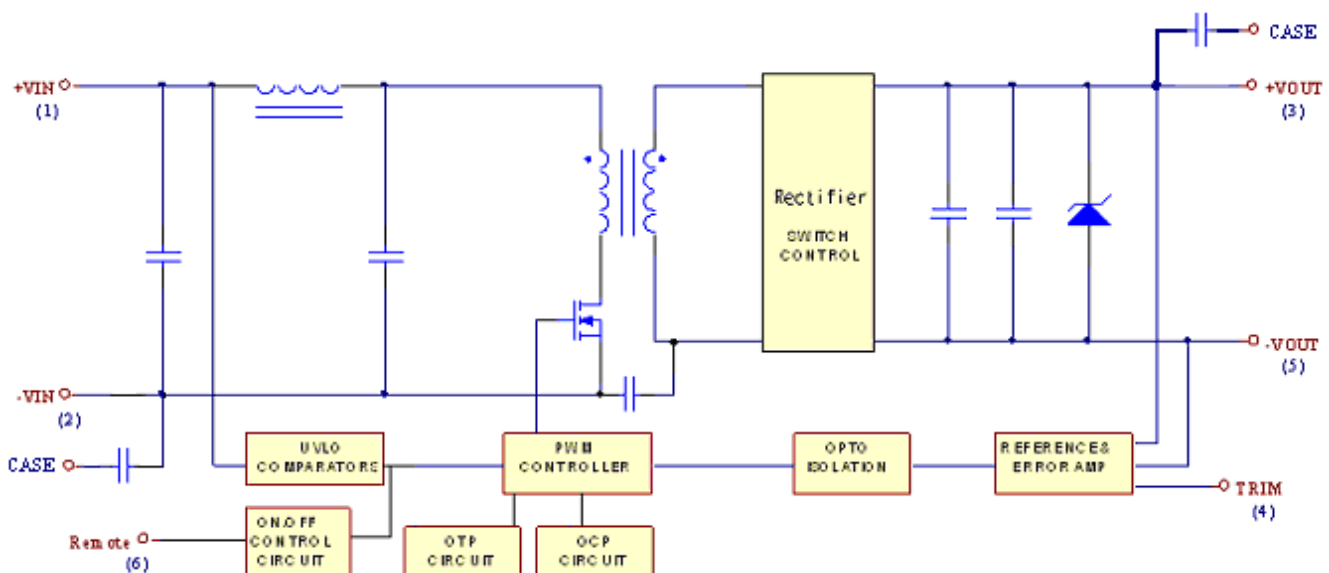

Figure 1 Electrical Block Diagram for Single Output Modules

### 2. DC-DC Converter Features

- \* 75W Isolated Output
- \* Efficiency to 92.5%
- \* Low No Load Power Consumption
- \* 2.05" X1.2" X0.4" Six-Sided Shield Metal Case
- \* Standard 2"X1" Pin Out Compatible
- \* 4:1 Input Range
- \* Regulated Outputs
- \* Fixed Switching Frequency
- \* Input Under Voltage Protection
- \* Over Current Protection
- \* Remote On/Off
- \* Continuous Short Circuit Protection
- \* All Ceramic Capacitor Design Inside
- \* Safety Meets IEC/EN/UL62368-1
- \* Full Load Operation Up to  $54^{\circ}\text{C}$  with Heat-Sink  
LBT127(M-C655)Natural Convection



# ECLB75W 75 Watt Isolated DC-DC Converters

## Application Note V10 July 2019

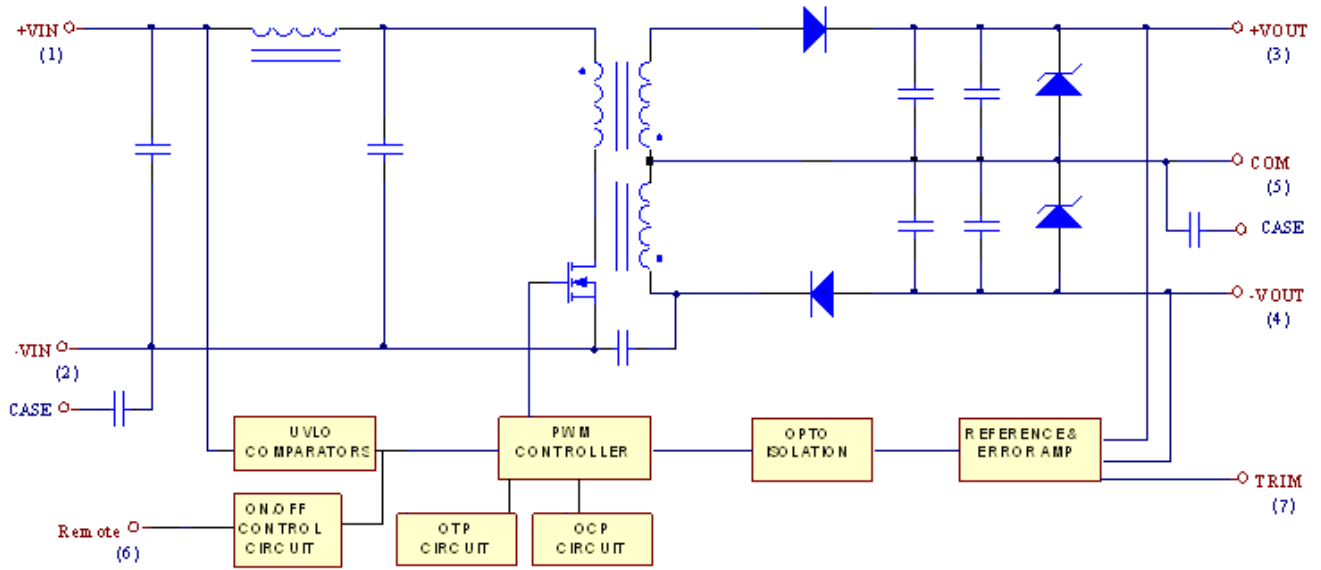

Figure 2 Electrical Block Diagram for Dual Output Modules



# ECLB75W 75 Watt Isolated DC-DC Converters

## Application Note V10 July 2019

### 4. Technical Specifications

(All specifications are typical at nominal input, full load at 25°C unless otherwise noted.)

#### ABSOLUTE MAXIMUM RATINGS

PARAMETER	NOTES and CONDITIONS	Device	Min.	Typical	Max.	Units
Input Voltage						
Continuous		24Vin	-0.3		36	Vdc
		48Vin	-0.3		75	
Transient	100ms	24Vin			50	Vdc
		48Vin			100	
Operating Ambient Temperature	Derating, above 22°C	All	-40		+85	°C
Case Temperature		All			105	°C
Storage Temperature		All	-55		+125	°C
Input/Output Isolation Voltage	1 minute; input/output,	All			2250	V <sub>dc</sub>
	1 minute; input/case,	All			1600	V <sub>dc</sub>
	1 minute; output/case	All			1600	V <sub>dc</sub>

#### INPUT CHARACTERISTICS

PARAMETER	NOTES and CONDITIONS	Device	Min.	Typical	Max.	Units
Operating Input Voltage		24Vin	9	24	36	Vdc
		48Vin	18	48	75	
Input Under Voltage Lockout						
Turn-On Voltage Threshold		24Vin	8	8.5	8.8	V <sub>dc</sub>
		48Vin	15.5	16	16.5	
Turn-Off Voltage Threshold		24Vin	7.5	7.8	8.1	V <sub>dc</sub>
		48Vin	14.5	15	15.5	
Lockout Hysteresis Voltage		24Vin		0.7		V <sub>dc</sub>
		48Vin		1		
Maximum Input Current	100% Load, Vin=9V	24Vin		9260		mA
	100% Load, Vin=18V	48Vin		4630		
No-Load Input Current	Vin=12V	24S05		10		mA
		24S12		10		
		24S15		10		
		24D12		12		
		24D15		12		
		24D24		18		
	Vin=24V	48S05		8		
		48S12		8		
		48S15		8		
		48D12		8		
		48D15		8		
		48D24		8		
Input Filter	Pi filter.	All				
Inrush Current (I <sup>2</sup> t)	As per ETS300 132-2	All			0.1	A <sup>2</sup> s
Input Reflected-Ripple Current	P-P thru 1.2uH inductor, 5Hz to 20MHz, <b>See 6.3</b>	All			30	mA



# ECLB75W 75 Watt Isolated DC-DC Converters

## Application Note V10 July 2019

### OUTPUT CHARACTERISTIC

PARAMETER	NOTES and CONDITIONS	Device	Min.	Typical	Max.	Units
Output Voltage Set Point	Vin=nominal input, Io= Io <sub>max.</sub> , Tc=25°C	Vo=5V	4.95	5	5.05	Vdc
		Vo=12V	11.88	12	12.12	
		Vo=15V	14.85	15	15.15	
		Vo=±12V	±11.88	±12	±12.12	
		Vo=±15V	±14.85	±15	±15.15	
		Vo=±24V	±23.76	±24	±24.24	
Output Voltage Balance	Vin=nominal input, Io=Io <sub>max.</sub>	Dual			±1.0	%
Output Voltage Regulation						
Load Regulation	Io=full load to min. Load	All			±0.5	%
Line Regulation	Vin=high line to low line, full Load	All			±0.2	%
Cross Regulation	Load cross variation 10%/100%	Dual			±5	%
Temperature Coefficient	Tc=-40°C to 105°C	All			±0.02	%/°C
Output Voltage Ripple and Noise (5Hz to 20MHz bandwidth)						
Peak-to-Peak	Full Load, Measured with 1uF MLCC <b>See 6.12</b>	Vo=5V			100	mV
		Vo=12V			150	
		Vo=15V			150	
		Vo=±12V			150	
		Vo=±15V			150	
		Vo=±24V			240	
RMS	Full Load, Measured with 1uF MLCC <b>See 6.12</b>	Vo=5V			40	mV
		Vo=12V			60	
		Vo=15V			60	
		Vo=±12V			60	
		Vo=±15V			60	
		Vo=±24V			100	
Operating Output Current Range		Vo=5V	0		15000	mA
		Vo=12V	0		6250	
		Vo=15V	0		5000	
		Vo=±12V	0		±3120	
		Vo=±15V	0		±2500	
		Vo=±24V	0		±1560	
Output DC Current-Limit Inception	Hiccup Mode. Auto Recovery. <b>See 5.4</b>	All	110	135	160	%
Maximum Output Capacitance	Full load (resistive)	Vo=5V			15000	uF
		Vo=12V			6250	
		Vo=15V			5000	
		Vo=±12V			3120	
		Vo=±15V			2500	
		Vo=±24V			1560	
Output Voltage Trim Range	P <sub>out</sub> =max rated power, <b>See 6.10</b>	All	-20		+10	%



# ECLB75W 75 Watt Isolated DC-DC Converters

## Application Note V10 July 2019

Output Over Voltage Protection	Zener clamp, <b>See 5.5</b>	Vo=5.0V		6.2		Vdc
		Vo=12V		15		
		Vo=15V		18		
		Vo=±12V		±15		
		Vo=±15V		±18		
		Vo=±24V		±30		

### DYNAMIC CHARACTERISTICS

PARAMETER	NOTES and CONDITIONS	Device	Min.	Typical	Max.	Units
Output Voltage Current Transient						
Error Band	75% to 100% of $I_{o\_max}$ step load change	All			±5	%
Recovery Time	$d_i/d_t=0.1A/us$ (within 1% Vout nominal)	All			250	us
Turn-On Delay and Rise Time	Full load (Constant resistive load)					
Turn-On Delay Time, From On/Off Control	$V_{on/off}$ to 10% $V_{o\_set}$	All		15		ms
Turn-On Delay Time, From Input	$V_{in\_min}$ to 10% $V_{o\_set}$	All		15		ms
Output Voltage Rise Time	10% $V_{o\_set}$ to 90% $V_{o\_set}$	All		15		ms

### EFFICIENCY

PARAMETER	NOTES and CONDITIONS	Device	Min.	Typical	Max.	Units
100% Load	$V_{in}=12V$ , <b>See 6.8</b>	24S05		92		%
		24S12		92		
		24S15		92		
		24D12		91		
		24D15		91		
		24D24		91		
	$V_{in}=24V$ , <b>See 6.8</b>	48S05		92		
		48S12		92		
		48S15		92.5		
		48D12		91.5		
		48D15		91.5		
		48D24		92		
100% Load	$V_{in}=24V$ , <b>See 6.8</b>	24S05		91.5		%
		24S12		91		
		24S15		90.5		
		24D12		90.5		
		24D15		91		
		24D24		90.5		
	$V_{in}=48V$ , <b>See 6.8</b>	48S05		91.5		
		48S12		91		
		48S15		91		
		48D12		90.5		
		48D15		91		
		48D24		91.5		



# ECLB75W 75 Watt Isolated DC-DC Converters

## Application Note V10 July 2019

### ISOLATION CHARACTERISTICS

PARAMETER	NOTES and CONDITIONS	Device	Min.	Typical	Max.	Units
Isolation Voltage	1 minute; input/output	All			2250	Vdc
	1 minute; input/case				1600	
	1 minute; output/case				1600	
Isolation Resistance		All	1000			MΩ
Isolation Capacitance	Input/Output	All		1500		pF
	Input/Case			1000		
	Output/Case			1000		
Switching Frequency	Pulse wide modulation (PWM), Fixed	Single		270		KHz
		Dual		330		
On/Off Control, Positive Remote On/Off logic						
Logic Low (Module Off)	Von/off at Ion/off=1.0mA	All	0		1.2	V
Logic High (Module On)	Von/off at Ion/off=0.1uA	All	3.5 or Open Circuit		75	V
On/Off Control, Negative Remote On/Off logic						
Logic Low (Module Off)	Von/off at Ion/off=1.0mA	All	3.5 or Open Circuit		75	V
Logic High (Module On)	Von/off at Ion/off=0.1uA	All	0		1.2	V

### FEATURE CHARACTERISTICS

PARAMETER	NOTES and CONDITIONS	Device	Min.	Typical	Max.	Units
On/Off Current (for both remote on/off logic)	Ion/off at Von/off=0.0V	All		0.3	1	mA
Leakage Current (for both remote on/off logic)	Logic high, Von/off=15V	All			30	uA
Off Converter Input Current	Shutdown input idle current	All		4	10	mA
Over-Temperature Shutdown	Aluminum case temperature	All		110		°C
Over Temperature Recovery		All		100		°C

### GENERAL SPECIFICATIONS

PARAMETER	NOTES and CONDITIONS	Device	Min.	Typical	Max.	Units
MTBF	Io=100%of Io.max.; Ta=25°C per MIL-HDBK-217F	Vo=5.0V		904		K hours
		Vo=12V		840		
		Vo=15V		995		
		Vo=±12V		792		
		Vo=±15V		998		
		Vo=±24V		691		
Weight		All		39		grams
Case Material	Aluminum					
Base Plate Material	FR4					
Potting Material	UL 94V-0					
Pin Material	Base: Copper, Plating: Nickel with Matte Tin					
Shock/Vibration	MIL-STD-810F / EN61373					
Humidity	95% RH max. Non Condensing					
Altitude	5000m Operating Altitude, 12000m Transport Altitude					
Thermal Shock	MIL-STD-810F					
Fire & Smoke	Meets EN45545-2					
EMI	Meets EN55022, EN55032 with external input filter, see 7.2				Class A	



### 5. Main Features and Functions

#### 5.1 Operating Temperature Range

The ECLB75W series converters can be operated within a wide case temperature range of  $-40^{\circ}\text{C}$  to  $105^{\circ}\text{C}$ . Consideration must be given to the derating curves when ascertaining maximum power that can be drawn from the converter. The maximum power drawn from open LB case models is influenced by usual factors, such as:

- Input voltage range
- Output load current
- Forced air or natural convection
- Heat sink optional

#### 5.2 Remote On/Off

The remote on/off input feature of the converter allows external circuitry to turn the converter on or off. Active-high remote on/off is available as standard. The converter is turned on if the remote on/off pin is high ( $>3.5\text{Vdc}$  to 75 or open circuit). Setting the pin low (0 to  $<1.2\text{Vdc}$ ) will turn the converter 'off'. The signal level of the remote on/off input is defined with respect to  $-V_{in}$ . If not using the remote on/off pin, leave the pin open (module will be on). **See 6.14**

Logic State (Pin 2)	Negative Logic	Positive Logic
Logic Low – Switch Closed	Module on	Module off
Logic High – Switch Open	Module off	Module on

#### 5.3 UVLO (Under Voltage Lock Out)

Input under voltage lockout is standard on the ECLB75W unit. The unit will shut down when the input voltage drops below a threshold, and the unit will operate when the input voltage goes above the upper threshold.

lin Vs Vin

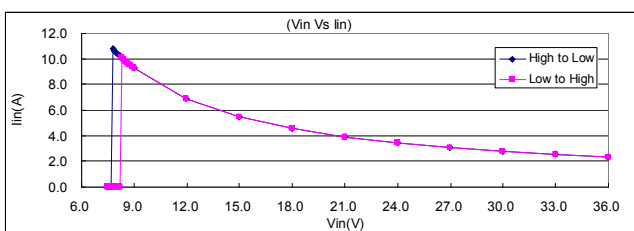

ECLB75W-24Vin

lin Vs Vin

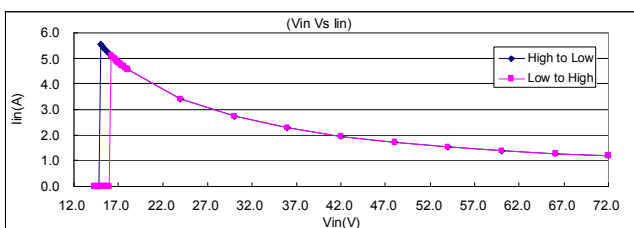

ECLB75W-48Vin

#### 5.4 Over Current Protection

All models have internal over current and continuous short circuit protection. The unit operates normally once the fault condition is removed. At the point of current limit inception, the converter will go into hiccup mode protection.

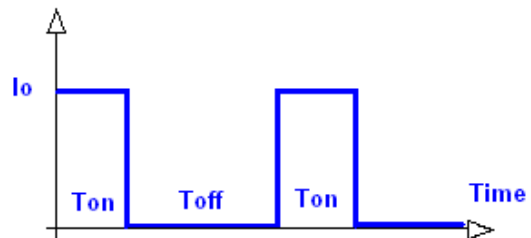
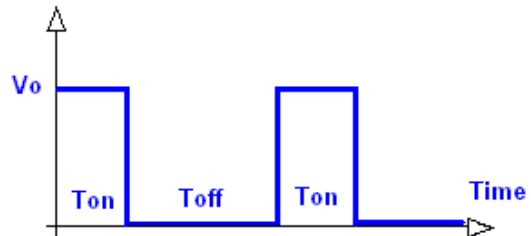

#### 5.5 Over Voltage Protection

The over-voltage protection consists of a zener diode to limiting the out voltage.

#### 5.6 Over-Temperature Protection (OTP)

The ECLB75W series converters are equipped with non-latching over-temperature protection. If the temperature exceeds a threshold of  $110^{\circ}\text{C}$  (typical) the converter will shut down, disabling the output. When the temperature has decreased the converter will automatically restart. The over-temperature condition can be induced by a variety of reasons such as external overload condition or a system fan failure.

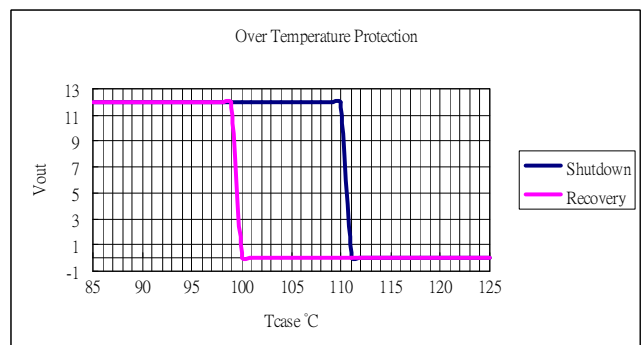



# ECLB75W 75 Watt Isolated DC-DC Converters

## Application Note V10 July 2019

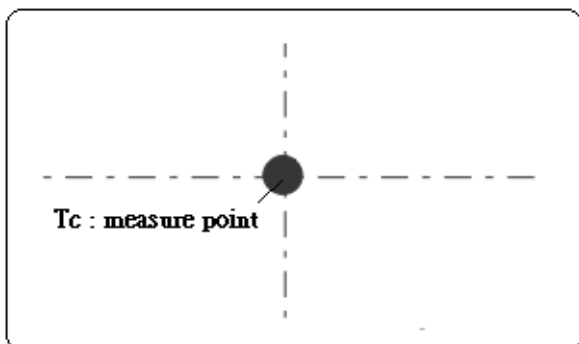

Lead Free Wave Soldering Profile

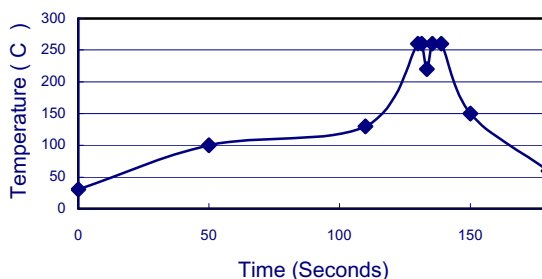

### 5.7 Output Voltage Adjustment

**Section 6.7** describes in detail how to trim the output voltage with respect to its set point. The output voltage on all models is adjustable within the range of +10% to -20%.

## 6. Applications

### 6.1 Recommended Layout PCB Footprints and Soldering Information

The system designer or the end user must ensure that other components and metal in the vicinity of the converter meet the spacing requirements to which the system is approved. Low resistance and low inductance PCB layout traces are the norm and should be used where possible. Due consideration must also be given to proper low impedance tracks between power module, input and output grounds. The recommended footprints and soldering profiles are shown below.

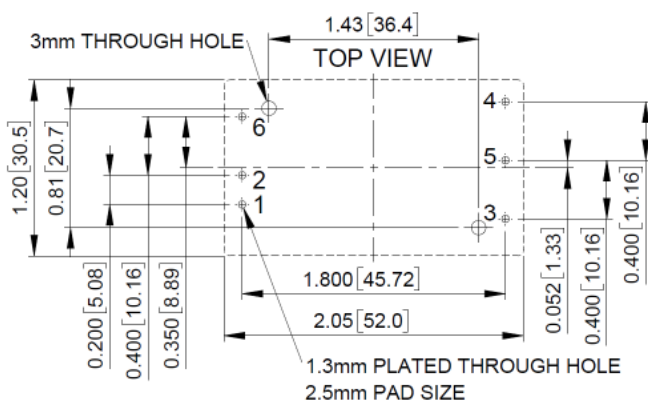

Note: Dimensions are in inches (millimeters)

Note :

1. Soldering Materials: Sn/Cu/Ni
2. Ramp up rate during preheat: 1.4 °C/Sec (From 50°C to 100°C)
3. Soaking temperature: 0.5 °C/Sec (From 100°C to 130°C), 60±20 seconds
4. Peak temperature: 260°C, above 250°C 3~6 Seconds
5. Ramp up rate during cooling: -10.0 °C/Sec (From 260°C to 150°C)

### 6.2 Connection for standard use

The connection for standard use is shown below. An external input capacitor (C1) 220uF for all models is recommended to reduce input ripple voltage. External output capacitors (C2 or C2') are recommended to reduce output ripple and noise, 1uF ceramic capacitor for other models.

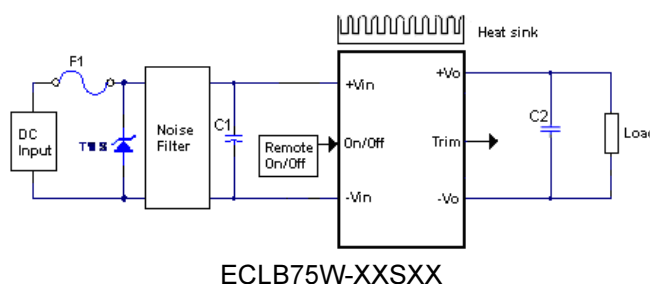

ECLB75W-XXSXX

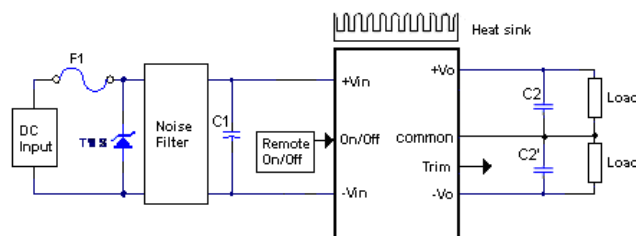

ECLB75W-XXDXX

Symbol	Component	Reference
F1,TVS	Input fuse,TVS	<b>Section 7.1</b>
C1	External capacitor on input side	<b>Note</b>
C2,C2'	External capacitor on the output side	<b>Section 6.12/6.13</b>
Noise Filter	External input noise	<b>Section 7.2</b>



	filter	
Remote On/Off	External Remote On/Off control	<b>Section 6.14</b>
Trim	External output voltage adjustment	<b>Section 6.10</b>
Heat sink	External heat sink	<b>Section 6.4/6.5/6.6/6.7</b>

module should not be allowed to exceed rated power ( $V_{o\_set} \times I_{o\_max}$ ).

**Note:**

If the impedance of input line is high, C1 capacitance must be more than above. Use more than two recommended capacitor above in parallel when ambient temperature becomes lower than -20 °C.

### 6.3 Input Capacitance at the Power Module

The converters must be connected to low AC source impedance. To avoid problems with loop stability source inductance should be low. Also, the input capacitors (Cin) should be placed close to the converter input pins to de-couple distribution inductance. However, the external input capacitors are chosen for suitable ripple handling capability. Low ESR capacitors are good choice. Circuit as shown in Figure 5 represents typical measurement methods for reflected ripple current. C1 and L1 simulate a typical DC source impedance. The input reflected-ripple current is measured by current probe to oscilloscope with a simulated.

source Inductance (L1).

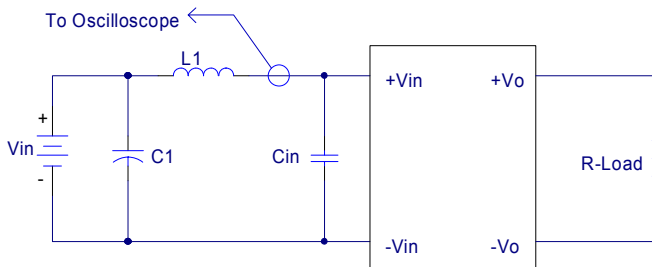

L1: 1.2uH

C1: None

Cin: 220uF ESR<0.7ohm @100KHz

Figure 5 Input Reflected-Ripple Test Setup

### 6.4 Convection Requirements for Cooling

To predict the approximate cooling needed for the half brick module, refer to the power derating curves in **section 6.6**. These derating curves are approximations of the ambient temperatures and airflows required to keep the power module temperature below its maximum rating. Once the module is assembled in the actual system, the module's temperature should be monitored to ensure it does not exceed 105°C as measured at the center of the top of the case (thus verifying proper cooling).

### 6.5 Thermal Considerations

The power module operates in a variety of thermal environments; however, sufficient cooling should be provided to help ensure reliable operation of the unit. Heat is removed by conduction, convection, and radiation to the surrounding environment. The example is presented in **section 6.6**. The power output of the



# ECLB75W 75 Watt Isolated DC-DC Converters

## Application Note V10 July 2019

### 6.6 Power De-Rating Curves for ECLB75W Series

Operating ambient temperature and de-rating curve.

Maximum case temperature under any operating condition should not exceed 105°C.

ECLB75W-24S05 Typical Derating Curve, Vin(nom)

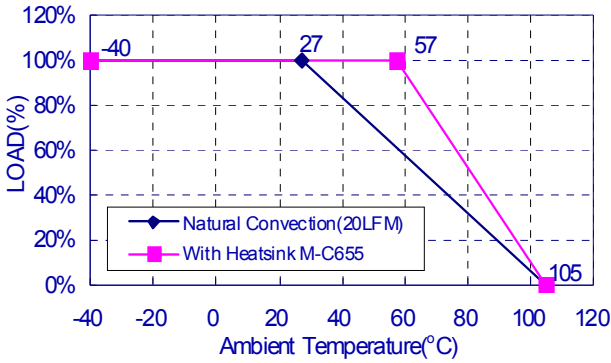

ECLB75W-24S12 Typical Derating Curve, Vin(nom)

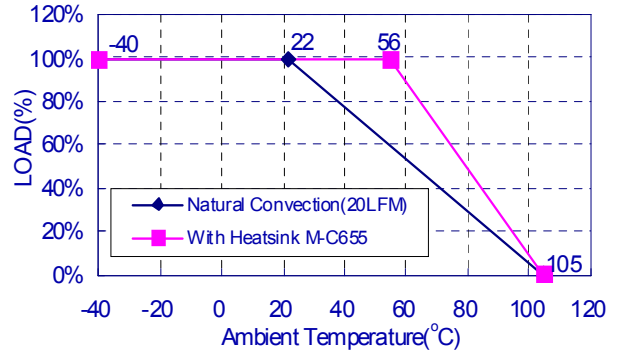

ECLB75W-24S15 Typical Derating Curve, Vin(nom)

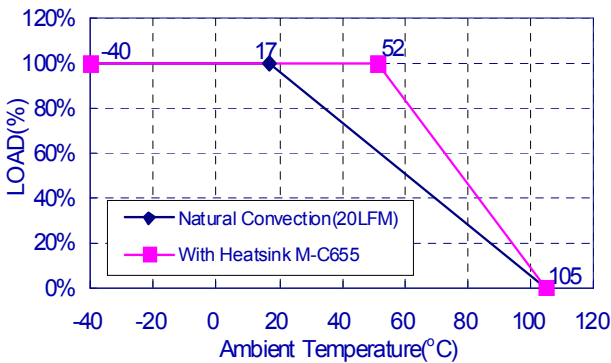

ECLB75W-24D12 Typical Derating Curve, Vin(nom)

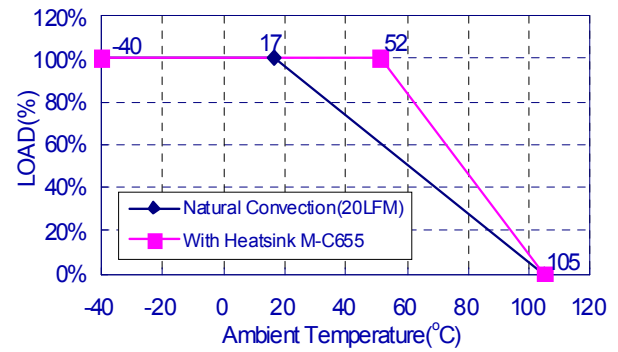

ECLB75W-24D15 Typical Derating Curve, Vin(nom)

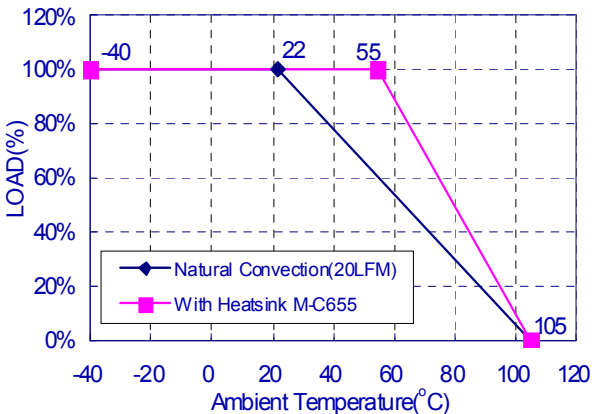

ECLB75W-24D24 Typical Derating Curve, Vin(nom)

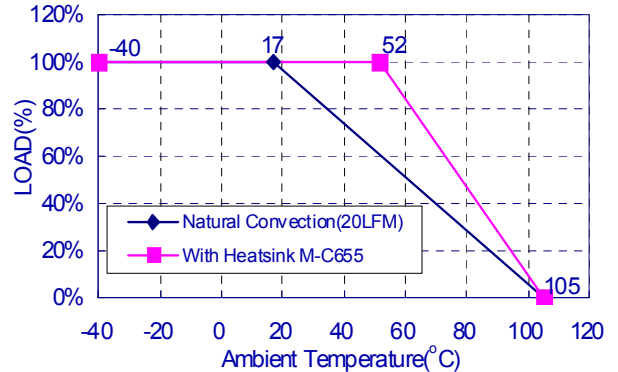



# ECLB75W 75 Watt Isolated DC-DC Converters

## Application Note V10 July 2019

ECLB75W-48S05 Typical Derating Curve, Vin(nom)

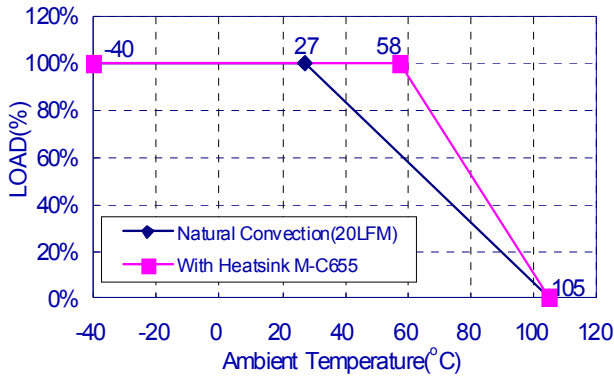

ECLB75W-48S12 Typical Derating Curve, Vin(nom)

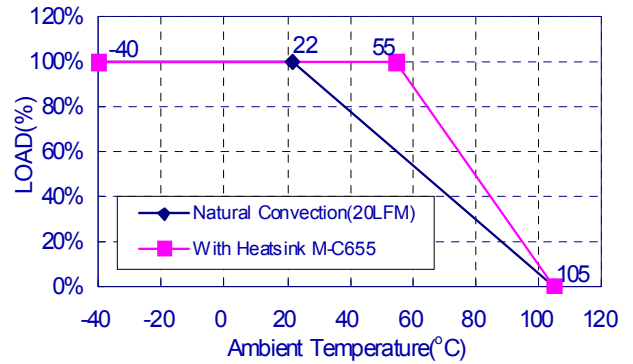

ECLB75W-48S15 Typical Derating Curve, Vin(nom)

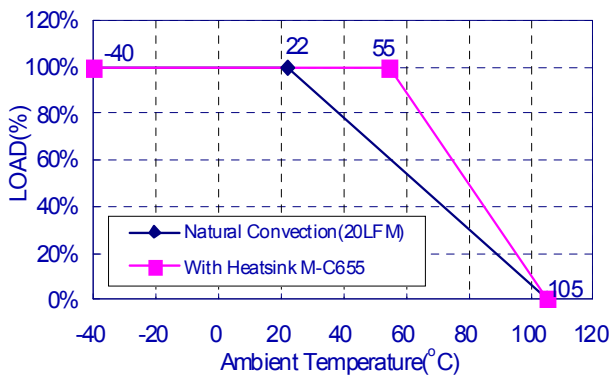

ECLB75W-48D12 Typical Derating Curve, Vin(nom)

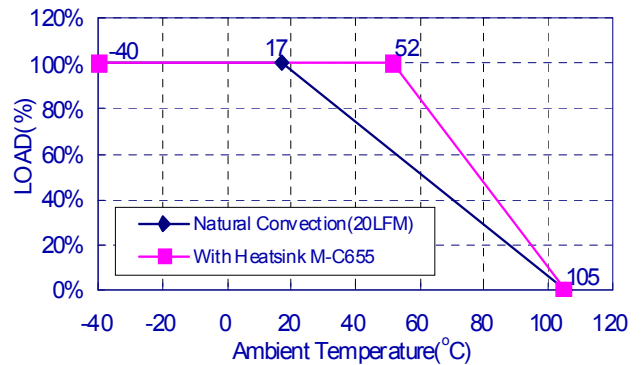

ECLB75W-48D15 Typical Derating Curve, Vin(nom)

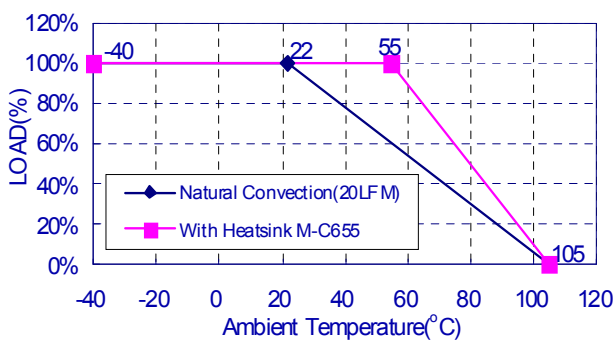

ECLB75W-48D24 Typical Derating Curve, Vin(nom)

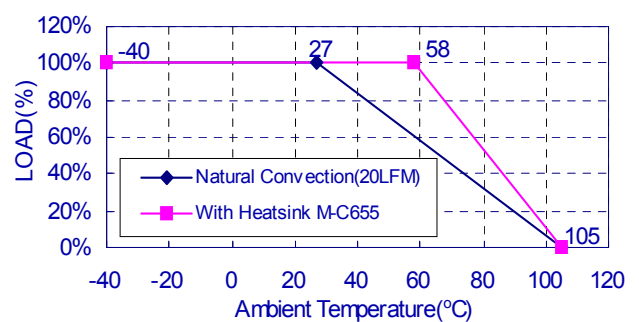



## ECLB75W 75 Watt Isolated DC-DC Converters

### Application Note V10 July 2019

---

#### Example (without heatsink):

The ECLB75W-24S05 operating at nominal line voltage, an output current of 15A, and a maximum ambient temperature of 22°C.

#### Solution:

Given:  $V_{in}=24V_{dc}$ ,  $V_o=5V_{dc}$ ,  $I_o=15A$

#### Determine Power dissipation ( $P_d$ ):

$$P_d = P_i - P_o = P_o(1-\eta)/\eta$$

$$P_d = 5 \times 15 \times (1-0.915)/0.915 = 6.97 \text{ Watts}$$

#### Determine airflow:

Airflow: Natural Convection

#### Check above Power de-rating curve:

Given:  $P_d=6.97W$  and  $T_a=22^\circ C$

**Verifying:** The maximum temperature rise  $\Delta T = P_d \times R_{ca} = 6.97 \times 11.2 = 78.064^\circ C$

The maximum case temperature  $T_c = T_a + \Delta T = 100^\circ C < 105^\circ C$

**Where:** The  $R_{ca}$  is thermal resistance from case to ambience.

The  $T_a$  is ambient temperature and the  $T_c$  is case temperature

#### Example (with heatsink M-C655):

The ECLB75W-48S05 with thermal pad SZ 29.5x49.8x0.25mm and heat sink LBT127(M-C655) operating at nominal line voltage, an output current of 15A, and a maximum ambient temperature of 54°C.

#### Solution:

Given:  $V_{in}=48V_{dc}$ ,  $V_o=5V_{dc}$ ,  $I_o=15A$

#### Determine Power dissipation ( $P_d$ ):

$$P_d = P_i - P_o = P_o(1-\eta)/\eta$$

$$P_d = 5.0 \times 15 \times (1-0.915)/0.915 = 6.97 \text{ Watts}$$

#### Determine airflow:

Airflow: Natural Convection

#### Check above Power de-rating curve:

Given:  $P_d=6.97W$  and  $T_a=54^\circ C$

**Verifying:** The maximum temperature rise  $\Delta T = P_d \times R_{ca} = 6.52 \times 6.8 = 47.396^\circ C$

The maximum case temperature  $T_c = T_a + \Delta T = 101.39^\circ C < 105^\circ C$

**Where:** The  $R_{ca}$  is thermal resistance from case to ambience.

The  $T_a$  is ambient temperature and the  $T_c$  is case temperature



# ECLB75W 75 Watt Isolated DC-DC Converters

## Application Note V10 July 2019

### 6.7 LB Heat Sinks

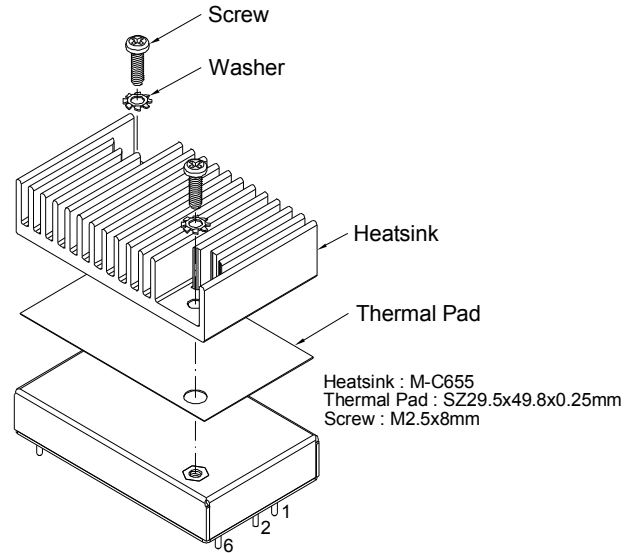
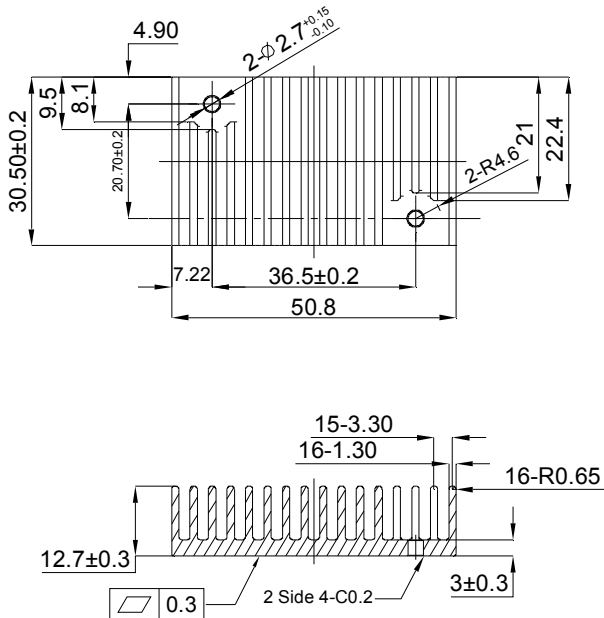

#### LBT127(M-C655) (G6620790202)

Transverse Heat Sink

All Dimensions in mm

Thermal Pad: SZ29.5x49.8x0.25mm (G6135041753)

Screw: M2.5x8mm (G75A3300922)

Washer: (G75A5750052)

Rca: 11.2°C/W (typ.), At natural convection

Rca: 6.8°C/W (typ.), At natural convection, mounted 85x50x1.6mm 20z test board.

Recommended PCB Layout with de-rating. (86x50x1.6mm, 20z.)

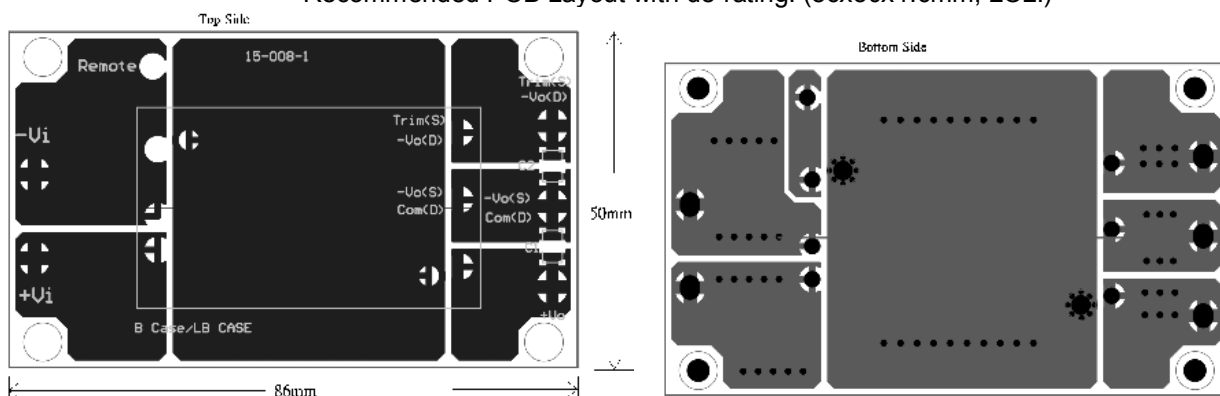



# ECLB75W 75 Watt Isolated DC-DC Converters

## Application Note V10 July 2019

### 6.8 Efficiency vs. Load Curves

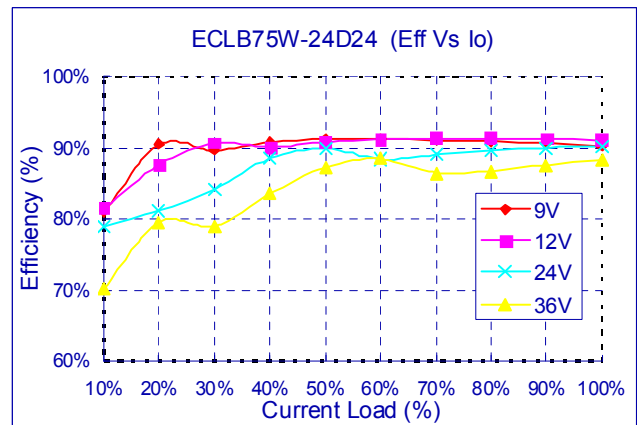
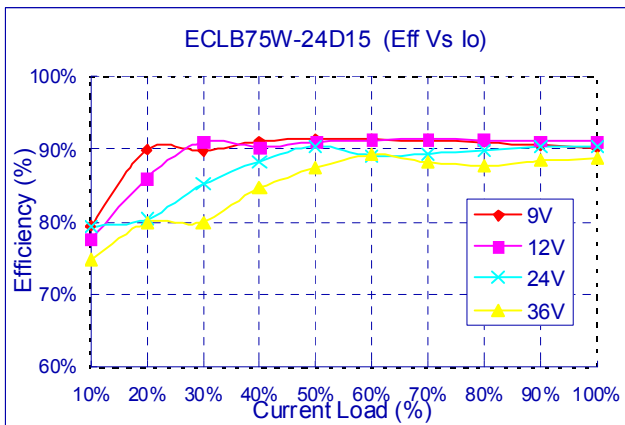
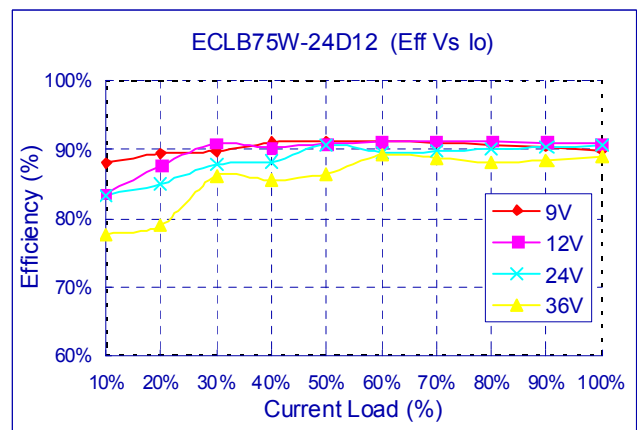
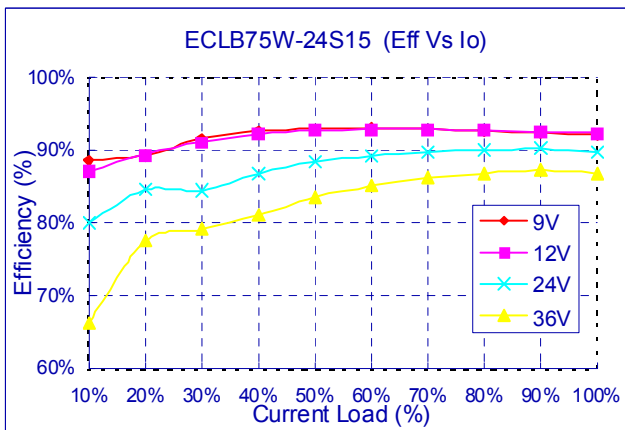
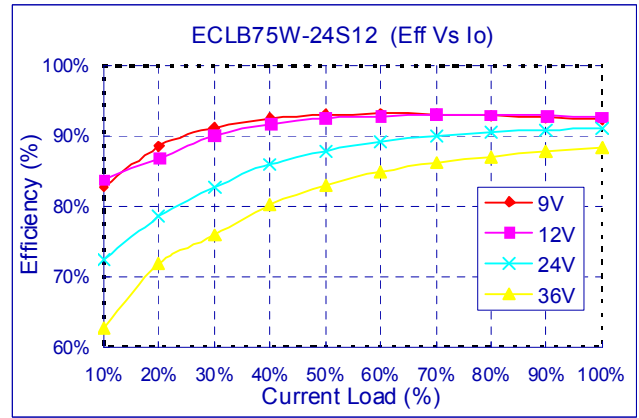
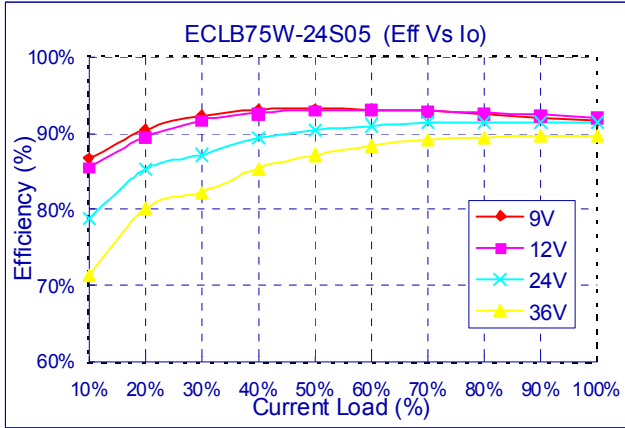



# ECLB75W 75 Watt Isolated DC-DC Converters

## Application Note V10 July 2019

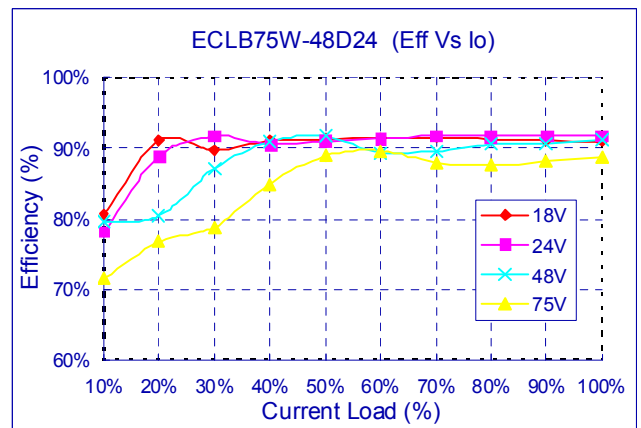
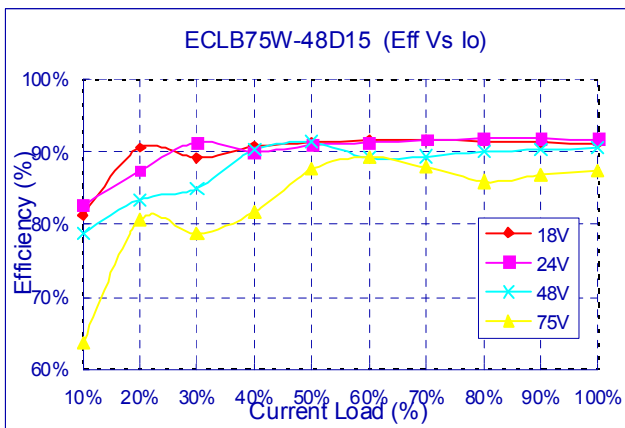
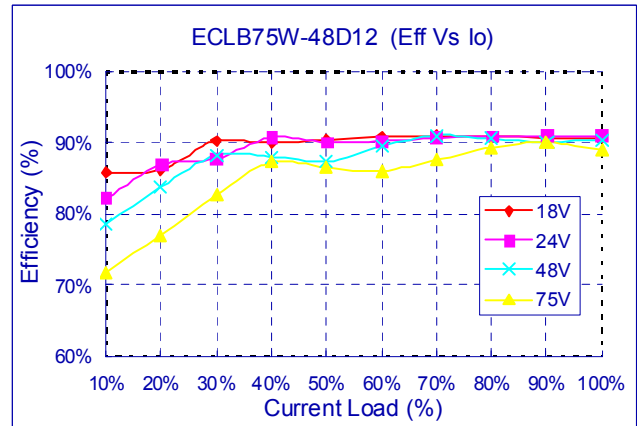
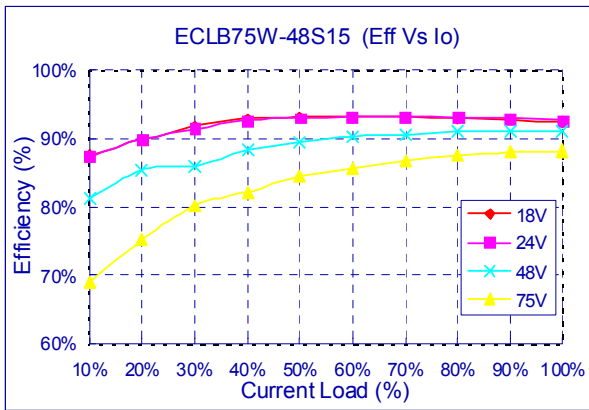
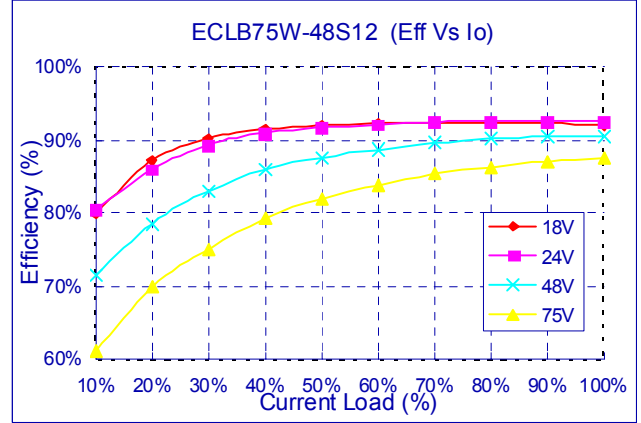
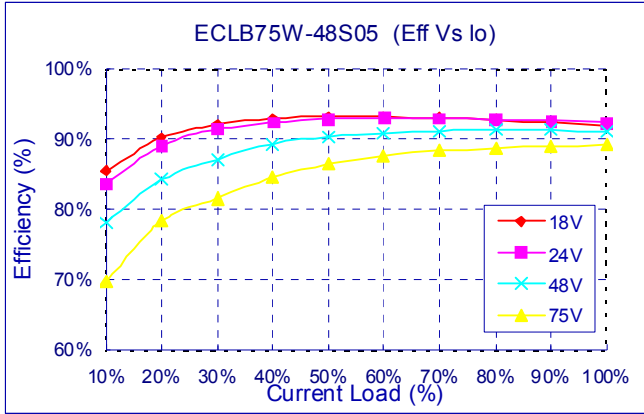



# ECLB75W 75 Watt Isolated DC-DC Converters

## Application Note V10 July 2019

### 6.9 Test Set-Up

The basic test set-up to measure parameters such as efficiency and load regulation is shown in Figure 6. When testing the modules under any transient conditions please ensure that the transient response of the source is sufficient to power the equipment under test. We can calculate the

- Efficiency
- Load regulation and line regulation.

The value of efficiency is defined as:

$$\eta = \frac{V_O \times I_O}{V_{IN} \times I_{IN}} \times 100\%$$

Where

- $V_O$  is output voltage,
- $I_O$  is output current,
- $V_{IN}$  is input voltage,
- $I_{IN}$  is input current.

The value of load regulation is defined as:

$$Load.reg = \frac{V_{FL} - V_{NL}}{V_{NL}} \times 100\%$$

Where

- $V_{FL}$  is the output voltage at full load
- $V_{NL}$  is the output voltage at zero load

The value of line regulation is defined as:

$$Line.reg = \frac{V_{HL} - V_{LL}}{V_{LL}} \times 100\%$$

Where

- $V_{HL}$  is the output voltage of maximum input voltage at full load.
- $V_{LL}$  is the output voltage of minimum input voltage at full load.

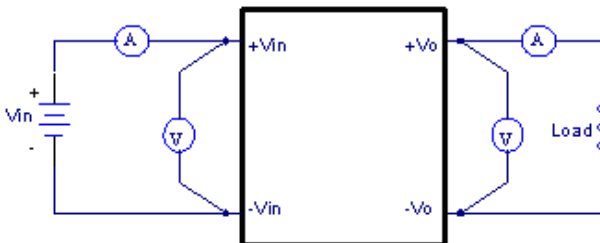

Figure 6 ECLB75W Series Test Setup

### 6.10 Output Voltage Adjustment

In order to trim the voltage up or down one needs to connect the trim resistor either between the trim pin and -Vo for trim-up and between trim pin and +Vo for trim-down. The output voltage trim range is +10%/-20%. (Single output models only) This is shown in Figure 7 and 8:

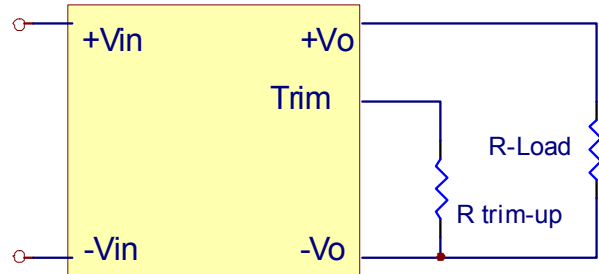

Figure 7 Trim-up Voltage Setup



# ECLB75W 75 Watt Isolated DC-DC Converters

## Application Note V10 July 2019

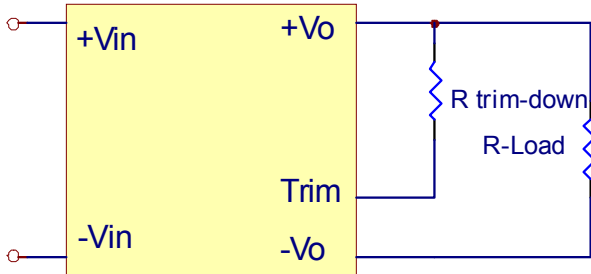

Figure 8 Trim-down Voltage Setup

### 6.10.1 The ECLB75W-XXS05 value of $R_{trim-up}$ define as:

$$R_{trim-up} = \left[ \frac{R1 \times R3^2 \times Vr - R2 \times R3 \times (R2 + R3) \times (Vo - Vo_{nom})}{(R2 + R3)^2 \times (Vo - Vo_{nom})} \right] - Rt \text{ (K}\Omega\text{)}$$

### 6.10.2 The ECLB75W-XXS12,XXS15 and XXDXX value of $R_{trim-up}$ defined as:

$$R_{trim-up} = \left[ \frac{Vr \times R1 \times (R2 + R3)}{R2 \times (Vo - Vo_{nom})} \right] - Rt \text{ (K}\Omega\text{)}$$

Where

$R_{trim-up}$  is the external resistor in Kohm.

$V_{O, nom}$  is the nominal output voltage.

$V_O$  is the desired output voltage.

$R1, Rt, R2, R3$  and  $Vr$  are internal to the unit and are defined in Table 1.

Table 1 – Trim up and Trim down Resistor Values

Model Number	Output Voltage(V)	R1 (KΩ)	R2 (KΩ)	R3 (KΩ)	Rt (KΩ)	Vr (V)
ECLB75W-XXS05	5.0	2.4	1.2	1.2	1.5	2.5
ECLB75W-XXS12	12.0	9.1	3	2.32	18	2.5
ECLB75W-XXS15	15.0	9.1	2.27	2.32	18	2.5
ECLB75W-XXD12	±12.0	15.4	2.43	5.6	33	2.5
ECLB75W-XXD15	±15.0	24	2.565	4.3	47	2.5
ECLB75W-XXD24	±24.0	36	2.475	9.1	68	2.5

For example, to trim-up the output voltage of 5.0V module (ECLB75W-24S05) by 10% to 5.5V,  $R_{trim-up}$  is calculated as follows:

$$V_O - V_{O, nom} = 5.5 - 5.0 = 0.5V,$$

$$R1 = 2.4 \text{ K}\Omega,$$

$$R2 = 1.2 \text{ K}\Omega,$$

$$R3 = 1.2 \text{ K}\Omega,$$

$$Rt = 1.5 \text{ K}\Omega, Vr = 2.5 \text{ V}$$

$$R_{trim-up} =$$

$$\left[ \frac{2.4 \times 1.2^2 \times 2.5 - 1.2 \times 1.2 \times (1.2 + 1.2) \times 0.5}{(1.2 + 1.2)^2 \times 0.5} \right] - 1.5 = 0.9 \text{ (K}\Omega\text{)}$$

For example, to trim-up the output voltage of ±24V(48V) module (ECLB75W-24D24) by 10% to ±26.4V(52.8V),  $R_{trim-up}$  is calculated as follows:

$$V_O - V_{O, nom} = 52.8 - 48 = 4.8V,$$

$$R1 = 36 \text{ K}\Omega,$$

$$R2 = 2.475 \text{ K}\Omega,$$

$$R3 = 9.1 \text{ K}\Omega,$$

$$Rt = 68 \text{ K}\Omega,$$

$$Vr = 2.5 \text{ V}$$

$$R_{trim-up} = \left( \frac{2.5 \times 36 \times (9.1 + 2.475)}{2.475 \times 4.8} \right) - 68 = 19.69 \text{ (K}\Omega\text{)}$$

### The typical value of $R_{trim-up}$

Trim up %	5V	12V	15V	±12V	±15V	±24V
	$R_{trim-up}$ (KΩ)					
1%	27.90	318.1	288.6	497.1	488.2	808.8
2%	12.90	150.1	135.3	232.0	220.6	370.4
3%	7.90	94.06	84.22	143.7	131.4	224.3
4%	5.40	66.05	58.67	99.53	86.82	151.2
5%	3.90	49.24	43.33	73.02	60.06	107.3
6%	2.90	38.03	33.11	55.35	42.21	78.15
7%	2.19	30.03	25.81	42.73	29.47	57.27
8%	1.65	24.02	20.33	33.26	19.91	41.61
9%	1.23	19.35	16.07	25.90	12.48	29.43
10%	0.90	15.62	12.67	20.01	6.53	19.69

### 6.10.3 The ECLB75W-XXS05 value of $R_{trim-down}$ defined as:

$$R_{trim-down} =$$

$$\frac{R1 \times R3 \times (R1 + R2) \times Vr - [R3 \times (R1 + R2) \times (R2 + R3)] \times (Vo - Vo_{nom})}{(R2 + R3)^2 \times (Vo - Vo_{nom})}$$

$$- Rt \text{ (K}\Omega\text{)}$$

### 6.10.4 The ECLB75W-XXS12,XXS15 and XXDXX value of of $R_{trim-down}$ defined as:

$$R_{trim-down} = R1 \times \left[ \frac{Vr \times R1}{(Vo_{nom} - Vo) \times R2} - 1 \right] - Rt \text{ (K}\Omega\text{)}$$

Where

$R_{trim-down}$  is the external resistor in Kohm.

$V_{O, nom}$  is the nominal output voltage.

$V_O$  is the desired output voltage.

$R1, Rt, R2, R3$  and  $Vr$  are internal to the unit and are defined in Table 1



# ECLB75W 75 Watt Isolated DC-DC Converters

## Application Note V10 July 2019

For example, to trim-down the output voltage of 5.0V module (ECLB75W-24S05) by 20% to 4V, R trim-down is calculated as follows:

$$V_{O,nom} - V_o = 5.0 - 4.0 = 1.0V$$

$$R1 = 2.4 \text{ K}\Omega$$

$$R2 = 1.2 \text{ K}\Omega$$

$$R3 = 1.2 \text{ K}\Omega$$

$$Rt = 1.5 \text{ K}\Omega$$

$$Vr = 2.5 \text{ V}$$

$R_{trim-down} =$

$$\frac{2.4 \times 1.2 \times (2.4 + 1.2) \times 2.5 - [1.2 \times (2.4 + 1.2) \times (1.2 + 1.2)] \times 1}{(1.2 + 1.2)^2 \times 1}$$

$$- 1.5 = 1.2 \text{ (K}\Omega)$$

For example, to trim-down the output voltage of  $\pm 24V(48V)$  module (ECLB75W-24D24) by 20% to  $\pm 19.2V(38.4V)$ , R trim-down is calculated as follows:

$$V_{O,nom} - V_o = 48 - 38.4 = 9.6V$$

$$R1 = 36 \text{ K}\Omega$$

$$R2 = 2.475 \text{ K}\Omega$$

$$R3 = 9.1 \text{ K}\Omega$$

$$Rt = 68 \text{ K}\Omega,$$

$$Vr = 2.5 \text{ V}$$

$$R_{trim-down} = 36 \times \left[ \frac{2.5 \times 36}{9.6 \times 2.475} - 1 \right] - 68 = 32.36 \text{ (K}\Omega)$$

The typical value of  $R_{trim-down}$

Trim down %	5V	12V	15V	$\pm 12V$	$\pm 15V$	$\pm 24V$
	$R_{trim-down}$ (K $\Omega$ )					
1%	86.70	547.9	580.9	968.2	1800.	2623
2%	41.70	260.4	276.9	459.9	864.6	1259
3%	26.70	164.5	175.5	290.4	552.7	805.0
4%	19.20	116.6	124.9	205.7	396.8	577.8
5%	14.70	87.91	94.50	154.9	303.2	441.4
6%	11.70	68.74	74.23	121.0	240.8	350.5
7%	9.56	55.05	59.76	96.83	196.3	285.6
8%	7.95	44.78	48.90	78.68	162.9	236.9
9%	6.70	36.80	40.46	64.56	136.9	199.0
10%	5.70	30.41	33.70	53.26	116.1	168.7
11%	4.88	25.18	28.17	44.02	99.12	143.9
12%	4.20	20.82	23.57	36.32	84.95	123.2
13%	3.62	17.14	19.67	29.80	72.95	105.7
14%	3.13	13.98	16.33	24.22	62.67	90.81
15%	2.70	11.24	13.43	19.38	53.76	77.82
16%	2.33	8.84	10.90	15.14	45.96	66.45
17%	1.99	6.73	8.66	11.40	39.08	56.43
18%	1.70	4.85	6.68	8.08	32.96	47.52
19%	1.44	3.17	4.90	5.11	27.49	39.54
20%	1.20	1.65	3.30	2.43	22.57	32.36

### 6.12 Output Ripple and Noise

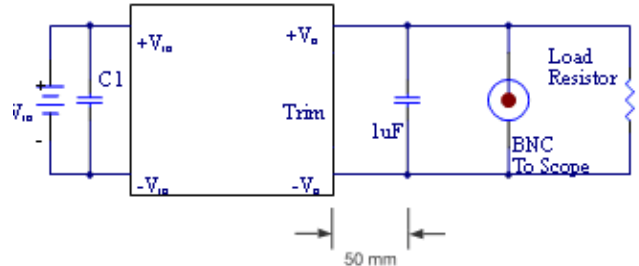

Output ripple and noise measured with 1uF ceramic capacitor for other models. A 20 MHz bandwidth oscilloscope is normally used for the measurement.

The conventional ground clip on an oscilloscope probe should never be used in this kind of measurement. This clip, when placed in a field of radiated high frequency energy, acts as an antenna or inductive pickup loop, creating an extraneous voltage that is not part of the output noise of the converter.



Another method is shown in below, in case of coaxial-cable/BNC is not available. The noise pickup is eliminated by pressing scope probe ground ring directly against the  $-V_{out}$  terminal while the tip contacts the  $+V_{out}$  terminal. This makes the shortest possible connection across the output terminals.

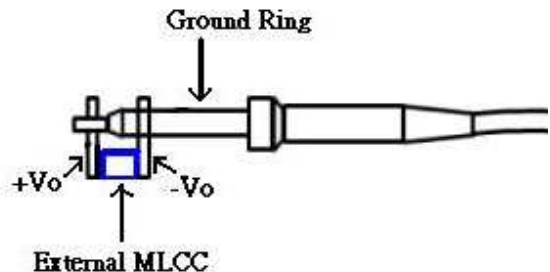

### 6.13 Output Capacitance

The ECLB75W series converters provide unconditional stability with or without external capacitors. For good transient response low ESR output capacitors should be located close to the point of load. These series converters are designed to work with load capacitance to see technical specifications.



# ECLB75W 75 Watt Isolated DC-DC Converters

## Application Note V10 July 2019

### 6.14 Remote On/Off Circuit

The converter remote On/Off circuit built-in on input side. The ground pin of input side Remote On/Off circuit is  $-V_{in}$  pin. Refer to 5.2 for more details. Inside connection examples see below.

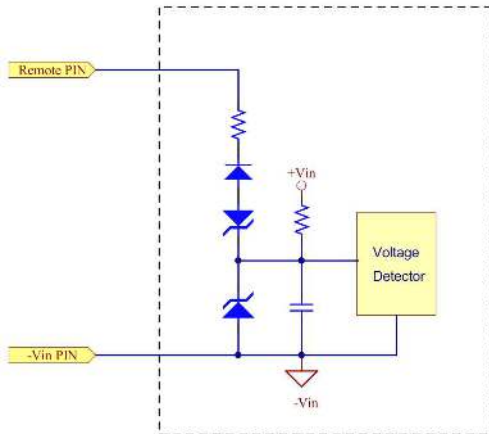

Inside Remote On/Off Circuit Schematic

External connection examples see below.

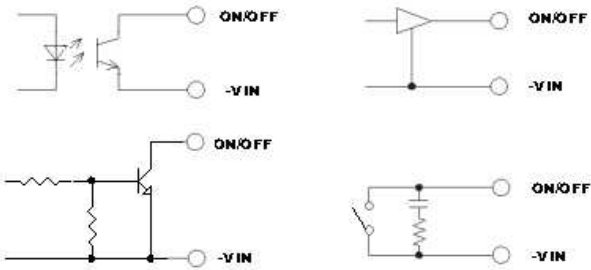

External Remote On/Off Connection Example



# ECLB75W 75 Watt Isolated DC-DC Converters

## Application Note V10 July 2019

### 7. Safety & EMC

#### 7.1 Input Fusing and Safety Considerations.

The ECLB75W series converters have not an internal fuse. However, to achieve maximum safety and system protection, always use an input line fuse. We recommended a time delay fuse 15A for 24Vin models and 8A for 48Vin modules. Figure 10 circuit is recommended by a Transient Voltage Suppressor diode across the input terminal to protect the unit against surge or spike voltage and input reverse voltage.

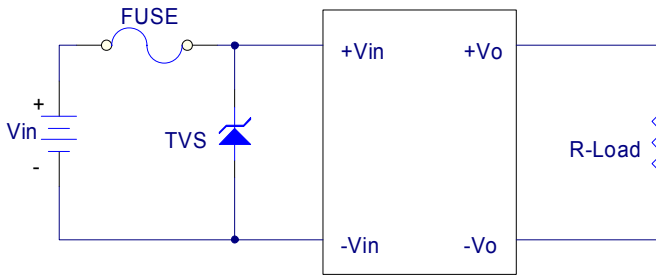

Figure 10 Input Protection

#### 7.2 EMC Considerations

EMI Test Standard: EN55022 Class A Conducted Emission

Test Condition: Input Voltage: Nominal, Output Load: Full Load

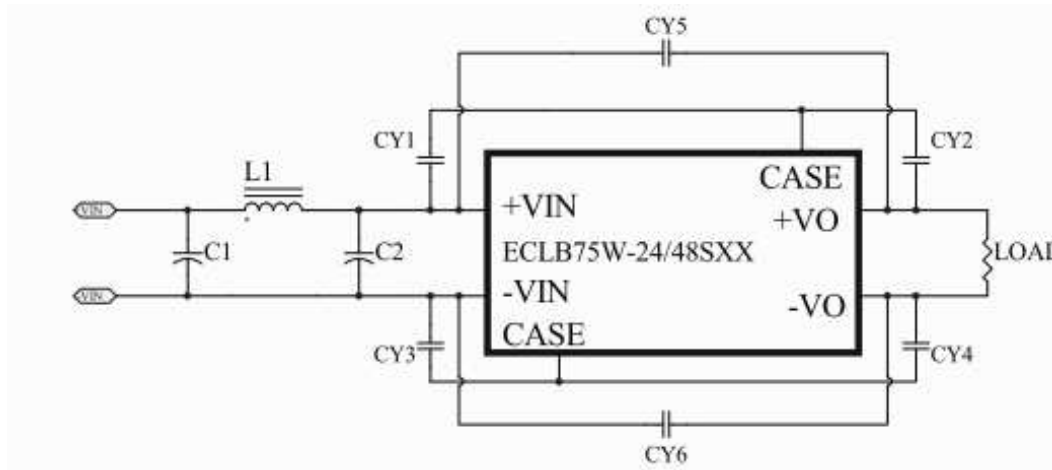

Figure 11 Connection circuit for conducted EMI testing



# ECLB75W 75 Watt Isolated DC-DC Converters

## Application Note V10 July 2019

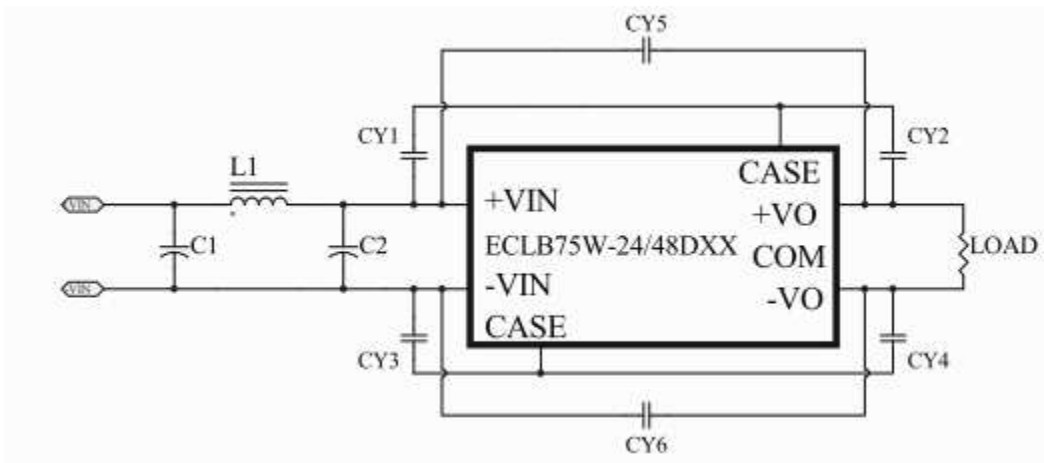

Figure 12 Connection circuit for conducted EMI testing

MODEL NO.	C1,C2	L1	CY1~CY6
ECLB75W series	120uF/100V/KY series Aluminum capacitor	2.8uH 17.5A SMD 1365 WURTH 7443551280	2200pF/3KV 1808 X7R MLCC

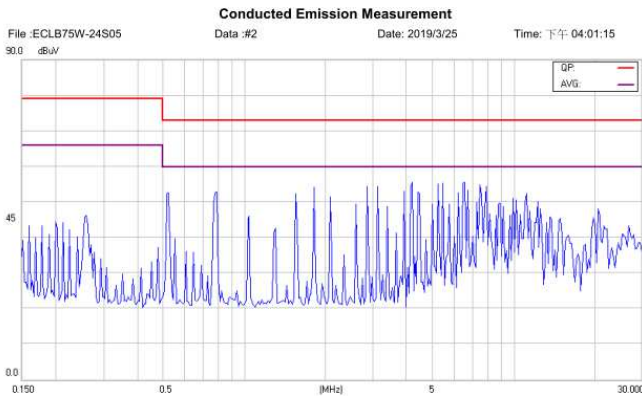

Figure 13 Conducted Class A of ECLB75W-24S05 LINE

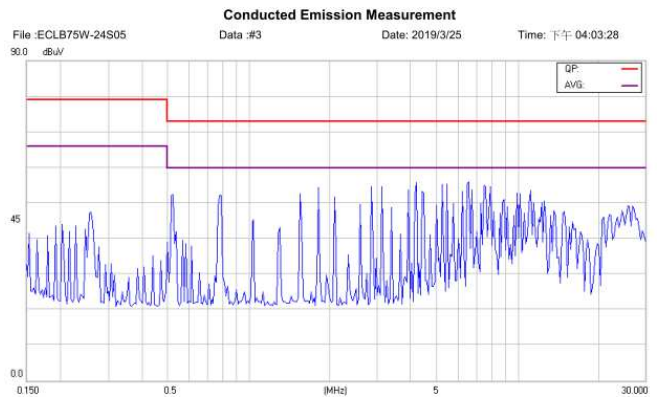

Figure 14 Conducted Class A ECLB75W-24S05 NATURE

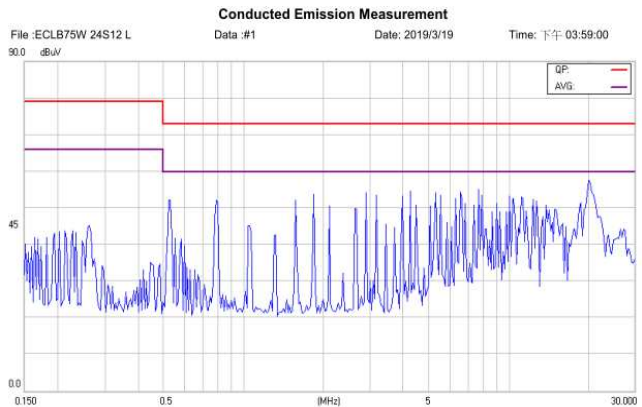

Figure 15 Conducted Class A of ECLB75W-24S12 LINE

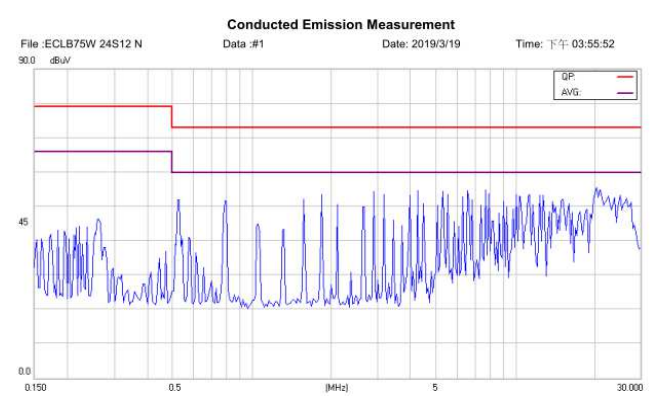

Figure 16 Conducted Class A ECLB75W-24S12 NATURE



# ECLB75W 75 Watt Isolated DC-DC Converters

## Application Note V10 July 2019

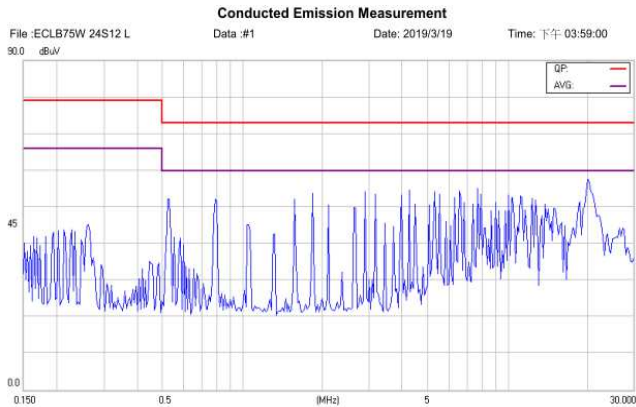

Figure 17 Conducted Class A of ECLB75W-24S15 LINE

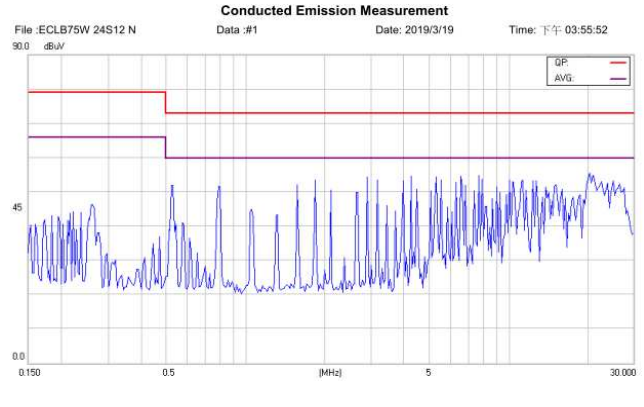

Figure 18 Conducted Class A ECLB75W-24S15 NATURE

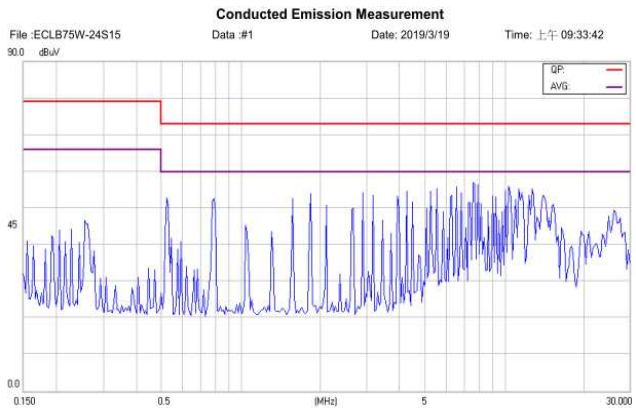

Figure 19 Conducted Class A of ECLB75W-48S05 LINE

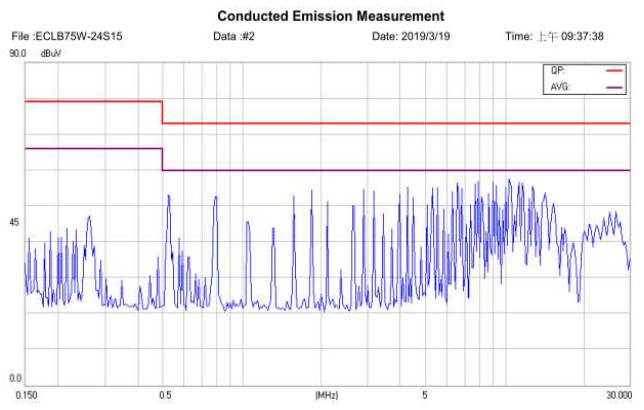

Figure 20 Conducted Class A ECLB75W-48S05 NATURE

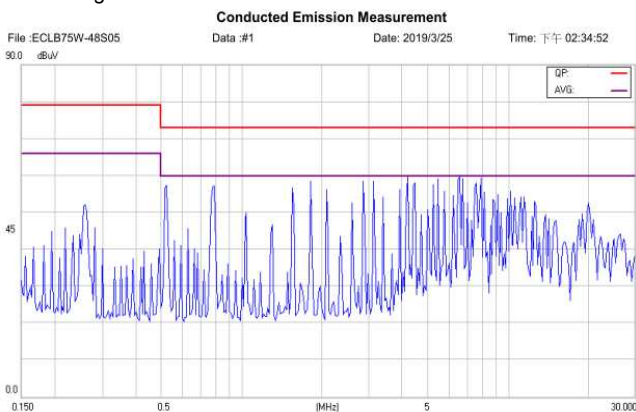

Figure 21 Conducted Class A of ECLB75W-48S12 LINE

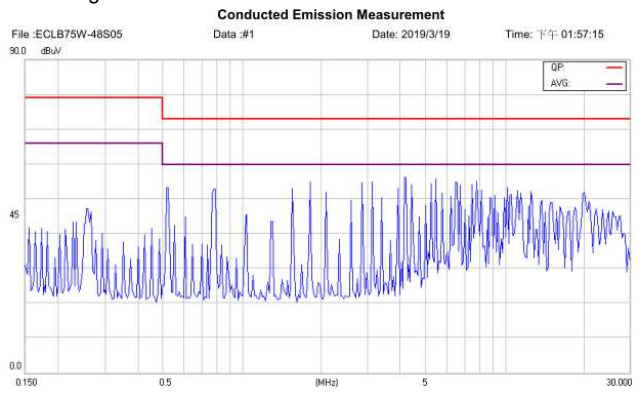

Figure 22 Conducted Class A ECLB75W-48S12 NATURE



# ECLB75W 75 Watt Isolated DC-DC Converters

## Application Note V10 July 2019

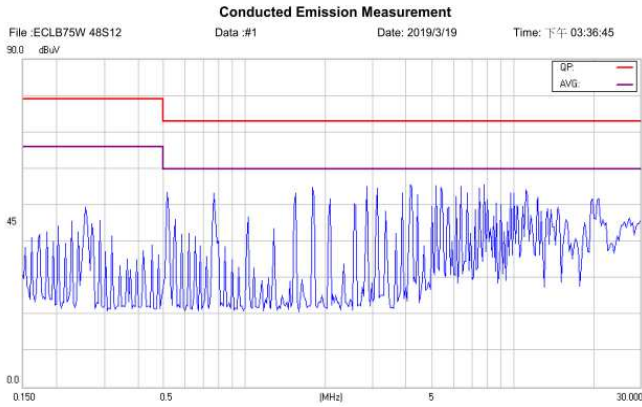

Figure 23 Conducted Class A of ECLB75W-48S15 LINE

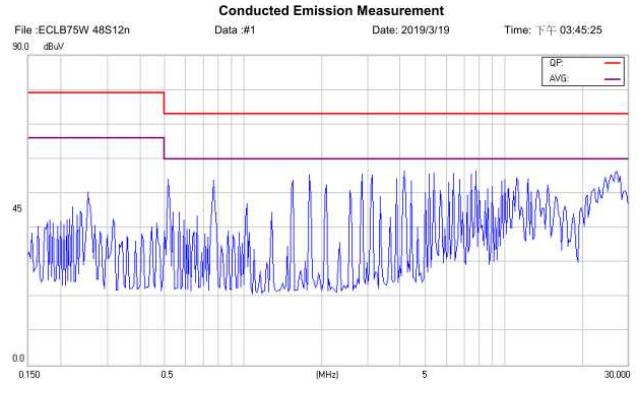

Figure 24 Conducted Class A ECLB75W-48S15 NATURE

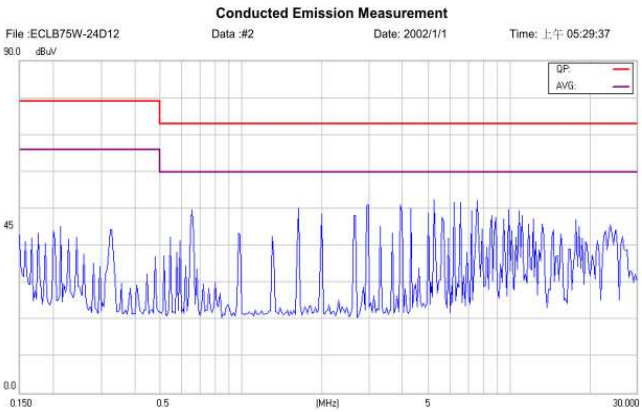

Figure 25 Conducted Class A of ECLB75W-24D12 LINE

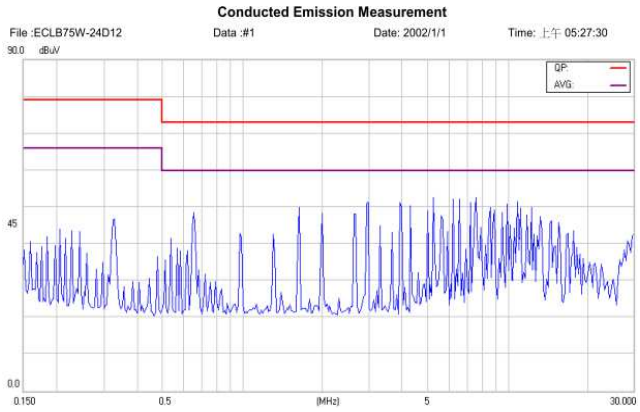

Figure 26 Conducted Class A ECLB75W-24D12 NATURE

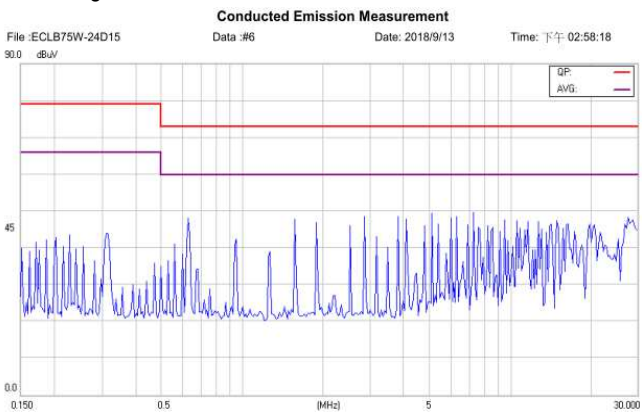

Figure 27 Conducted Class A of ECLB75W-24D15 LINE

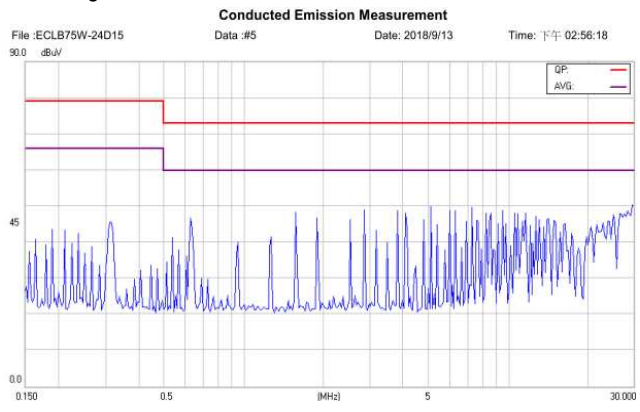

Figure 28 Conducted Class A ECLB75W-24D15 NATURE



# ECLB75W 75 Watt Isolated DC-DC Converters

## Application Note V10 July 2019

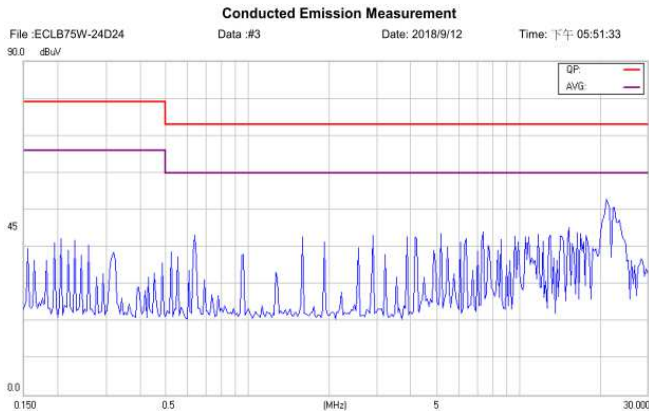

Figure 29 Conducted Class A of ECLB75W-24D24 LINE

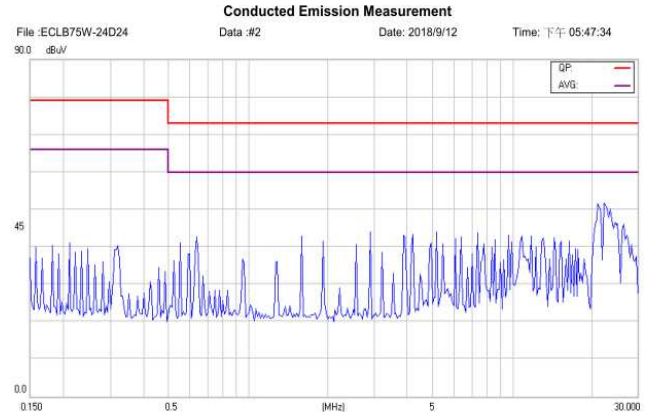

Figure 30 Conducted Class A ECLB75W-24D24 NATURE

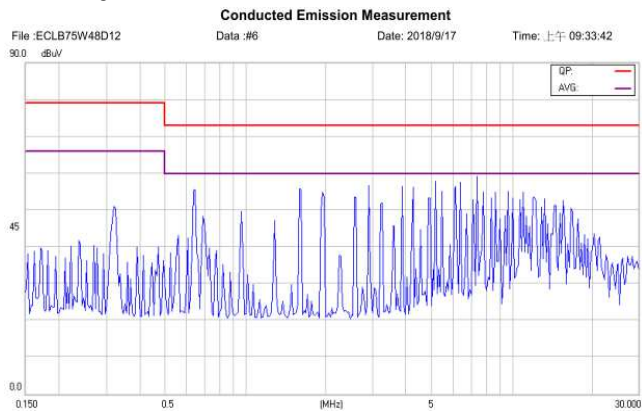

Figure 31 Conducted Class A of ECLB75W-48D12 LINE

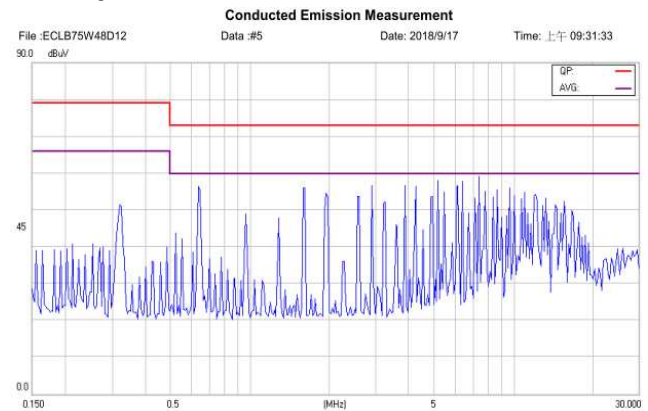

Figure 32 Conducted Class A ECLB75W-48D12 NATURE

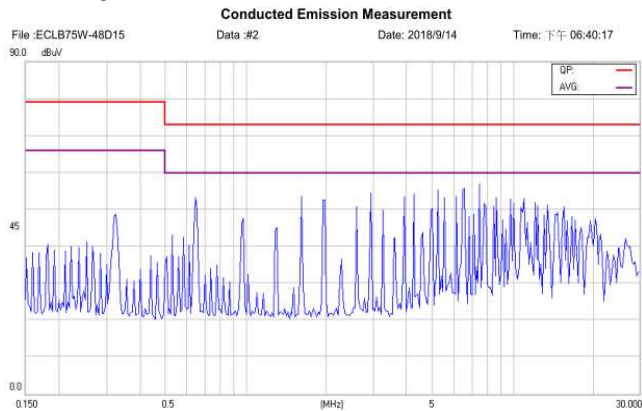

Figure 33 Conducted Class A of ECLB75W-48D15 LINE

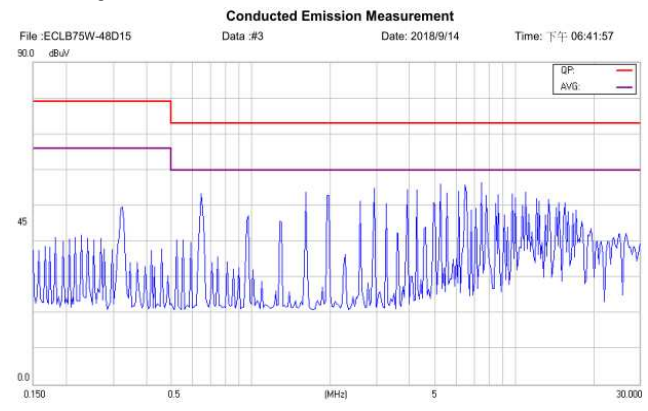

Figure 34 Conducted Class A ECLB75W-48D15 NATURE



# ECLB75W 75 Watt Isolated DC-DC Converters

## Application Note V10 July 2019

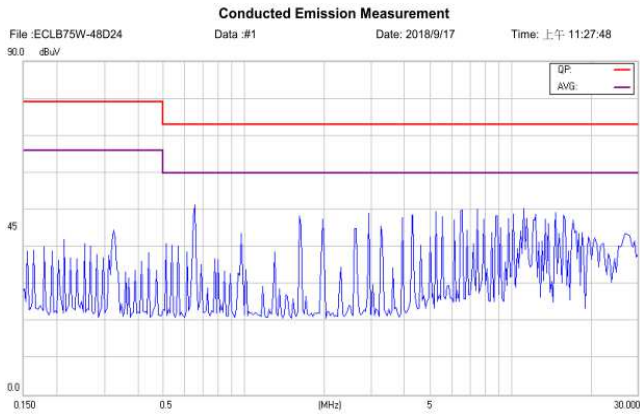

Figure 35 Conducted Class A of ECLB75W-48D24 LINE

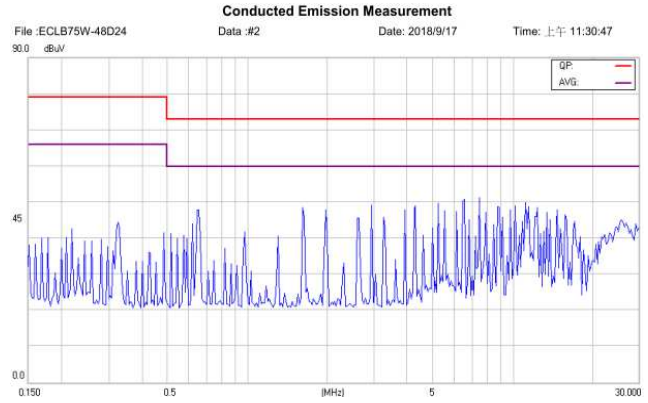

Figure 36 Conducted Class A ECLB75W-48D24 NATURE



# ECLB75W 75 Watt Isolated DC-DC Converters

## Application Note V10 July 2019

### 8. Part Number

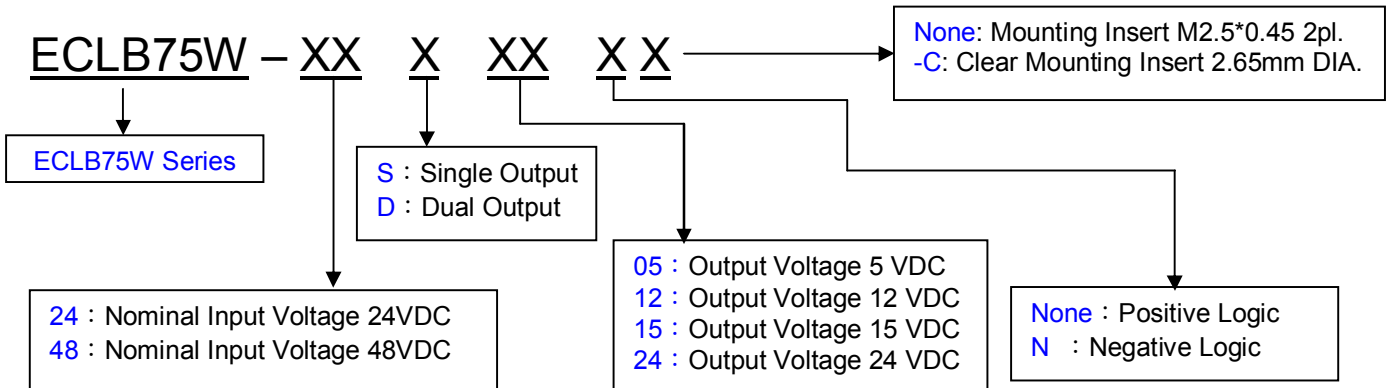

### 9. Mechanical Specifications

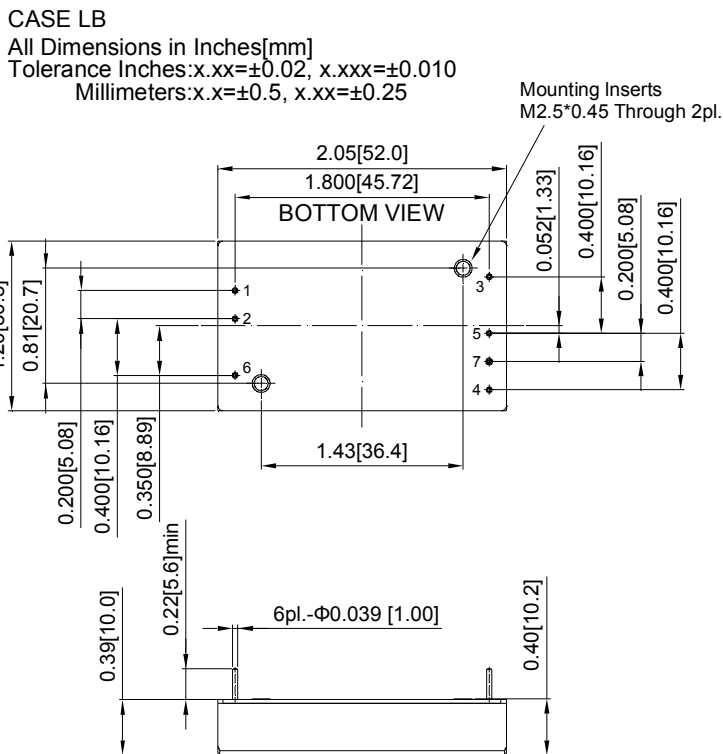

PIN CONNECTION		
PIN	Single Output	Dual Output
1	+V Input	+V Input
2	-V Input	-V Input
3	+V Output	+V Output
4	Trim	-V Output
5	-V Output	Common
6	Remote On / Off	
7	NP	Trim

CINCON ELECTRONICS CO., LTD.		
<b>Headquarter Office:</b> 14F, No.306, Sec.4, Hsin Yi Rd., Taipei, Taiwan Tel: 886-2-27086210 Fax: 886-2-27029852 E-mail: <a href="mailto:sales@cincon.com.tw">sales@cincon.com.tw</a> Web Site: <a href="http://www.cincon.com">http://www.cincon.com</a>	<b>Factory:</b> No. 8-1, Fu Kong Rd., Fu Hsing Industrial Park Fu Hsing Hsiang, ChangHua Hsien, Taiwan Tel: 886-4-7690261 Fax: 886-4-7698031	<b>Cincon American Office:</b> 1655 Mesa Verde Ave, Ste 180, Ventura, CA 93003 Tel: 805-639-3350 Fax: 805-639-4101 E-mail: <a href="mailto:info@cincon.com">info@cincon.com</a>