



## EC3SBW SERIES 15 WATT 4:1 INPUT DC-DC CONVERTERS



### FEATURES

- \* 15W Isolated Output
- \* 1"x1"x0.4" Shielded Metal Case
- \* Efficiency to 88%
- \* 4:1 Input Range
- \* Regulated Outputs
- \* Fixed Switching Frequency
- \* Input Under Voltage Protection
- \* Over Current Protection
- \* Remote On/Off
- \* Continuous Short Circuit Protection
- \* Without Tantalum Capacitors inside
- \* Safety Meets IEC/EN/UL 62368-1

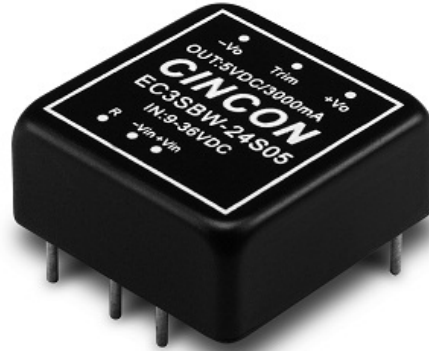

MODEL NUMBER	INPUT VOLTAGE	OUTPUT VOLTAGE	OUTPUT CURRENT		INPUT CURRENT		% EFF.	CAPACITOR Load Max.
			MIN.	MAX.	NO LOAD	FULL LOAD		
EC3SBW-24S33	9-36 VDC	3.3 VDC	0 mA	4000 mA	60 mA	632 mA	87	4000uF
EC3SBW-24S05	9-36 VDC	5 VDC	0 mA	3000 mA	70 mA	718 mA	87	3000uF
EC3SBW-24S12	9-36 VDC	12 VDC	0 mA	1250 mA	30 mA	718 mA	87	1250uF
EC3SBW-24S15	9-36 VDC	15 VDC	0 mA	1000 mA	30 mA	710 mA	88	1000uF
EC3SBW-24D05	9-36 VDC	±5 VDC	0 mA	±1500 mA	30 mA	735 mA	85	1500uF
EC3SBW-24D12	9-36 VDC	±12 VDC	0 mA	±625 mA	30 mA	718 mA	87	625uF
EC3SBW-24D15	9-36 VDC	±15 VDC	0 mA	±500 mA	30 mA	710 mA	88	470uF
EC3SBW-48S33	18-75 VDC	3.3 VDC	0 mA	4000 mA	40 mA	313 mA	88	4000uF
EC3SBW-48S05	18-75 VDC	5 VDC	0 mA	3000 mA	40 mA	355 mA	88	3000uF
EC3SBW-48S12	18-75 VDC	12 VDC	0 mA	1250 mA	20 mA	359 mA	87	1250uF
EC3SBW-48S15	18-75 VDC	15 VDC	0 mA	1000 mA	20 mA	359 mA	87	1000uF
EC3SBW-48D05	18-75 VDC	±5 VDC	0 mA	±1500 mA	20 mA	368 mA	85	1500uF
EC3SBW-48D12	18-75 VDC	±12 VDC	0 mA	±625 mA	20 mA	359 mA	87	625uF
EC3SBW-48D15	18-75 VDC	±15 VDC	0 mA	±500 mA	20 mA	359 mA	87	470uF

NOTE: 1. Nominal Input Voltage 24 or 48 VDC

# SPECIFICATIONS

All Specifications Typical At Nominal Line, Full Load, and 25°C Unless Otherwise Noted

## INPUT SPECIFICATIONS:

Input Voltage Range	24V	9 – 36V
	48V	18 – 75V
Input Surge Voltage (100ms max.)	24V	50Vdc max.
	48V	100Vdc max.
Under voltage lockout	24Vin power up	8.8V typ.
	24Vin power down	8.0V typ.
	48Vin power up	17V typ.
	48Vin power down	16V typ.
Input Filter		LC Type
Positive Logic Remote on/off Control:		
Logic Compatibility		CMOS or Open Collector TTL, Ref. to -Vin
Module On		>+3.5 to 75VDC or Open Circuit
Module Off		0 to <1.2VDC

## OUTPUT SPECIFICATIONS:

Voltage Accuracy		±1.5% max.
Voltage Balance (Dual)		±2.0% max.
Transient Response: 75% - 100% Step Load Change.		
Error Band		±5% Vout Nominal, Recovery Time <250us
Ripple & Noise, 20MHz BW (note3)		
	Vo=3.3 & 5V	75mV p-p max.
	Vo=12 & 15V	100mV p-p max.
Temperature Coefficient		±0.03%/°C max.
Short Circuit Protection		Continuous
Line Regulation (note1)	Single	±0.2% max.
	Dual	±0.5% max.
Load Regulation (note2)	Single	±0.2% max.
	Dual	±1.0% max.
Cross Regulation (Dual Output) Load Cross Variation 10%/100%		±5% max.
Over Voltage Protection		Zener or TVS Clamp
External Trim Adj. Range (Single Output Models Only)		±10%
Current Limit		110% - 175% Nominal Output
Start up Time		20ms max.

## GENERAL SPECIFICATIONS:

Efficiency		See Table
Isolation Voltage		1500 VDC min.
Isolation Resistance		10 <sup>9</sup> ohm min.
Isolation Capacitance		1000pF typ.
Switching Frequency		400KHz typ.
Operating Ambient Temperature Range		-40°C to +85°C
Derating. Above 68°C (note6)		Linearly to Zero Power at +105°C
Case Temperature (note4)		105°C
Cooling		Natural Convection
Storage Temperature Range		-55°C to +125°C
Humidity		95% RH max. Non Condensing
MTBF	MIL-HDBK-217F, GB, 25°C, Full Load .. S33/S05	950Khrs typ.
		Others .. 1300Khrs typ.
Dimensions		1.00x1.00x0.40 inches (25.4x25.4x10.2 mm)
Case Material		Black Coated Copper with Non-Conductive Base
Weight		18g

## NOTE:

1. Measured from high line to low line.
2. Measured from full load to min. load.
3. The output ripple and noise is measured with 10uF tantalum and 1uF ceramic capacitor across output.
4. Maximum case temperature under any operating condition should not be exceeded 105°C.
5. Suffix "+K-C087" type with heat sink.
6. Others model refer to application note.

## SIZE SB Dimensions:

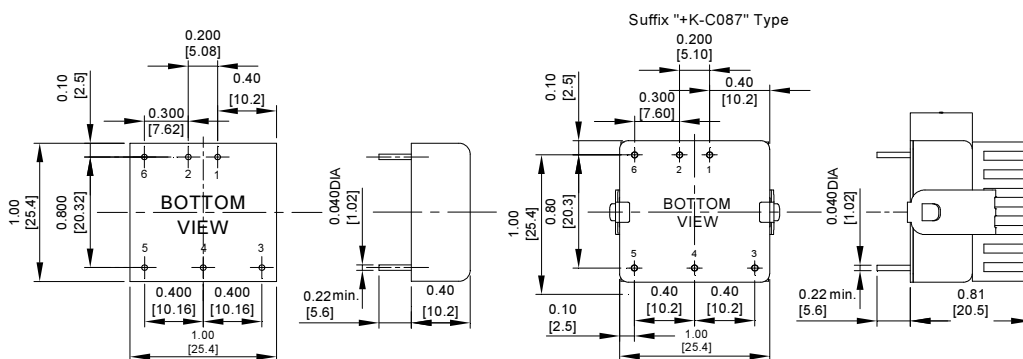

NOTE: Pin Size is 0.04±0.004 inch (1.0±0.1 mm) DIA  
 All Dimensions in Inches (mm)  
 Tolerances Inches: X.XX= ±0.02, X.XXX= ±0.010  
 Millimeters: X.X= ±0.5, X.XX= ±0.25

Pin	PIN CONNECTION	
	DIP Function	
1	+Input	+Input
2	-Input	-Input
3	+V Output	+V Output
4	Trim	Common
5	-V Output	-V Output
6	Remote	Remote

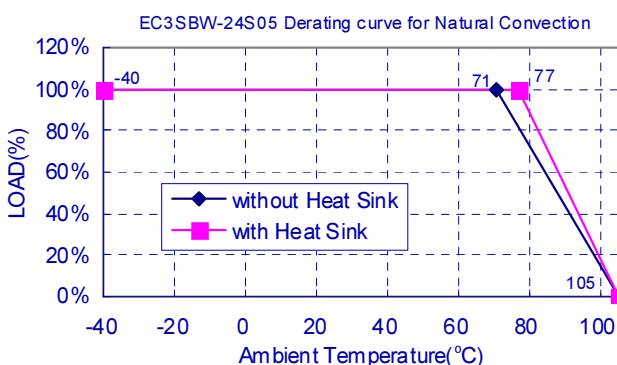

## EXTERNAL OUTPUT TRIM

