



# CQB60W-110S 60W Isolated DC-DC Converters Application Note V12 February 2018

## ISOLATED DC-DC CONVERTER CQB60W-110S SERIES APPLICATION NOTE



**Approved By:**

Department	Approved By	Checked By	Written By
Research and Development Department	Enoch	Hugo/Debby	Joyce
		Jacky	
Quality Assurance Department	Y.D.Yg	Benny	



# CQB60W-110S 60W Isolated DC-DC Converters Application Note V12 February 2018

---

## Contents

1. Introduction .....	3
2. DC-DC Converter Features .....	3
3. Electrical Block Diagram .....	3
4. Technical Specifications .....	4
5. Main Features and Functions .....	7
5.1 Operating Temperature Range .....	7
5.2 Output Voltage Adjustment .....	7
5.3 Over Current Protection .....	7
5.4 Output Overvoltage Protection .....	7
5.6 Remote On/Off .....	7
5.7 UVLO (Under voltage Lock Out) .....	7
5.8 Over Temperature Protection .....	7
6. Applications .....	7
6.1 Recommended Layout, PCB Footprint and Soldering Information .....	7
6.2 Convection Requirements for Cooling .....	8
6.3 Thermal Considerations .....	8
6.4 Power Derating .....	9
6.5 Quarter Brick Heat Sinks: .....	11
6.6 Efficiency VS. Load .....	12
6.7 Test Set-Up .....	13
6.8 Output Voltage Adjustment .....	13
6.9 Output Remote Sensing .....	14
6.10 Output Ripple and Noise .....	14
6.11 Output Capacitance .....	14
7. Safety & EMC .....	15
7.1 Input Fusing and Safety Considerations .....	15
7.2 EMC Considerations .....	15
7.3 Suggested Configuration for RIA12 Surge Test .....	18
8. Part Number .....	18
9. Mechanical Specifications .....	19
9.1 Mechanical Outline Diagrams .....	19



# CQB60W-110S 60W Isolated DC-DC Converters

## Application Note V12 February 2018

### 1. Introduction

The CQB60W-110S series offers 60 watts of output power with high power density in an industry standard quarter-brick package. The CQB60W-110S series is wide (4:1) input voltage range of 43-160VDC and provides a precisely regulated output. This series has features such as high efficiency 3000VDC isolation and a case operating temperature range of  $-40^{\circ}\text{C}$  to  $105^{\circ}\text{C}$ . The modules are fully protected against input UVLO (under voltage lock out), output short circuit, output overvoltage and over temperature conditions. Furthermore, the standard control functions include remote on/off and output voltage trimming. All models are highly suited to telecommunications, distributed power architectures, industrial, railway system, and mobile equipment applications.

### 2. DC-DC Converter Features

- 60W Isolated Output
- Efficiency to 92%
- 200KHz Switching Frequency
- 4:1 Input Range
- Regulated Output
- Remote On/Off
- Low No Load Power Consumption
- Over Temperature/Voltage/Current Protection
- Continuous Short Circuit Protection
- Quarter-Brick Size Meet Industrial Standard
- UL6095-1 (Basic Insulation) Approval
- 4000m Operating Altitude

### 3. Electrical Block Diagram

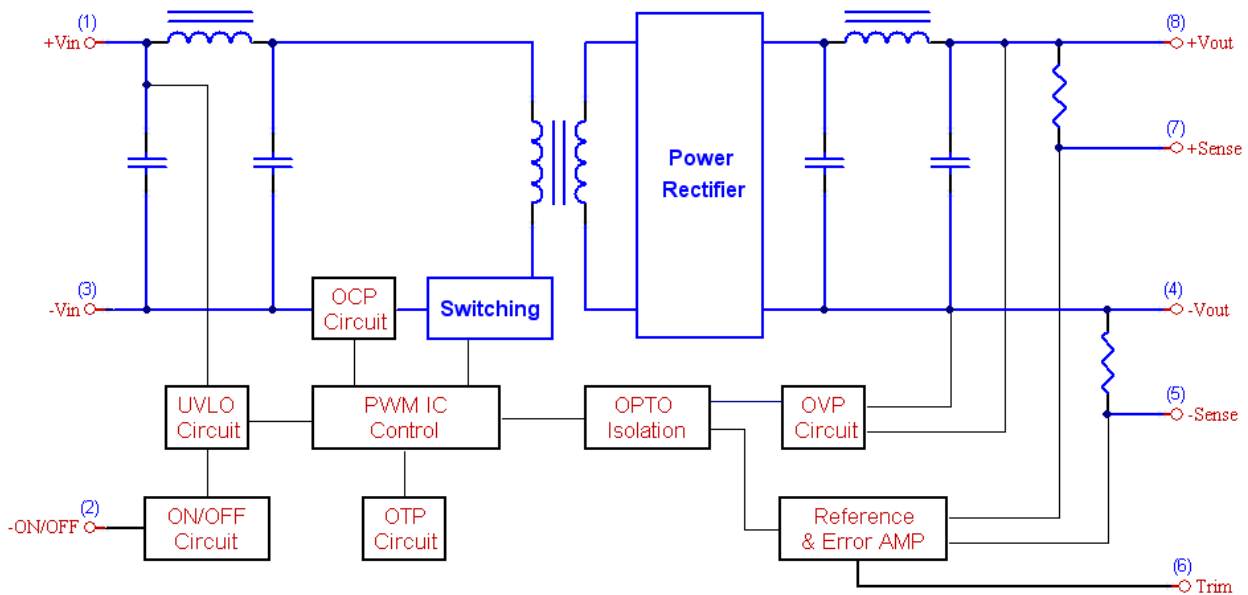

Electrical Block Diagram



# CQB60W-110S 60W Isolated DC-DC Converters

## Application Note V12 February 2018

### 4. Technical Specifications

(All specifications are typical at nominal input, full load at 25°C unless otherwise noted.)

#### ABSOLUTE MAXIMUM RATINGS

Stresses in excess of the absolute maximum ratings can cause permanent damage to the device. These are absolute stress ratings only, functional operation of the device is not implied at these or any other conditions in excess of those given in the operations sections of the data sheet. Exposure to absolute maximum ratings for extended periods can adversely affect the device reliability.

PARAMETER	NOTES and CONDITIONS	Device	Min.	Typical	Max.	Units
Input Voltage						
Continuous		All	-0.3		160	V <sub>dc</sub>
Transient	100ms	All			180	V <sub>dc</sub>
Operating Case Temperature		All	-40		105	°C
Storage Temperature		All	-55		125	°C
Isolation Voltage	1 minute; input/output, input/case,	All	3000			V <sub>dc</sub>
	1 minute; output/case	All	1500			

#### INPUT CHARACTERISTICS

PARAMETER	NOTES and CONDITIONS	Device	Min.	Typical	Max.	Units
Operating Input Voltage		All	43	110	160	V <sub>dc</sub>
Input Undervoltage Lockout						
Turn-On Voltage Threshold		All	40.5	42	42.5	V <sub>dc</sub>
Turn-Off Voltage Threshold		All	37.5	38	39.5	V <sub>dc</sub>
Lockout Hysteresis Voltage		All		3		V <sub>dc</sub>
Maximum Input Current	100% Load, V <sub>in</sub> =43V for 110SXX	All		1570		mA
No-Load Input Current	V <sub>in</sub> =Nominal	All		5		
Inrush Current (I <sup>2</sup> t)		All			0.1	A <sup>2</sup> s
Input Reflected Ripple Current	P-P thru 12uH inductor, 5Hz to 20MHz	All		30		mA

#### OUTPUT CHARACTERISTICS

PARAMETER	NOTES and CONDITIONS	Device	Min.	Typical	Max.	Units
Output Voltage Set Point	V <sub>in</sub> =Nominal V <sub>in</sub> , I <sub>o</sub> = I <sub>o_max</sub> , T <sub>c</sub> =25°C	Vo=5.0V	4.925	5	5.075	V <sub>dc</sub>
		Vo=12V	11.82	12	12.18	
		Vo=15V	14.775	15	15.225	
		Vo=24V	23.64	24	24.36	
		Vo=28V	27.58	28	28.42	
		Vo=48V	47.28	48	48.72	
Output Voltage Regulation						
Load Regulation	I <sub>o</sub> =I <sub>o_min</sub> to I <sub>o_max</sub>	All			±0.2	%
Line Regulation	V <sub>in</sub> =low line to high line	All			±0.2	%
Temperature Coefficient	TC=-40°C to 100°C	All			±0.03	%/°C



# CQB60W-110S 60W Isolated DC-DC Converters

## Application Note V12 February 2018

### OUTPUT CHARACTERISTICS

PARAMETER	NOTES and CONDITIONS	Device	Min.	Typical	Max.	Units
Output Voltage Ripple and Noise (5Hz to 20MHz bandwidth)						
Peak-to-Peak	Full load, 10uF tantalum and 1.0uF ceramic capacitors	Vo=5.0V Vo=12&15V Vo=24&28V Vo=48V			100 150 240 480	mV
RMS	Full load, 10uF solid tantalum and 1.0uF ceramic capacitors	Vo=5.0V Vo=12&15V Vo=24&28V Vo=48V			40 60 100 200	mV
Operating Output Current Range		Vo=5.0V Vo=12V Vo=15V Vo=24V Vo=28V Vo=48V	0 0 0 0 0 0		12 5 4 2.5 2.14 1.25	A
Output DC Current Limit Inception	Output Voltage=90% Nominal Output Voltage	All	110		165	%
Maximum Output Capacitance	Full load (resistive)	Vo=5.0V Vo=12V Vo=15V Vo=24V Vo=28V Vo=48V	0 0 0 0 0 0		6800 3300 3300 1200 1200 470	uF

### DYNAMIC CHARACTERISTICS

PARAMETER	NOTES and CONDITIONS	Device	Min.	Typical	Max.	Units
Output Voltage Current Transient						
Step Change in Output Current	75% to 100% of I <sub>o,max</sub>	All			±5	%
Setting Time (within 1% V <sub>out</sub> nominal)	d <sub>i</sub> /d <sub>t</sub> =0.1A/us	All			250	us
Turn-On Delay and Rise Time						
Turn-On Delay Time, From On/Off Control	V <sub>on/off</sub> to 10%V <sub>o,set</sub>	All		10		ms
Turn-On Delay Time, From Input	V <sub>in,min</sub> to 10%V <sub>o,set</sub>	All		15		ms
Output Voltage Rise Time	10%V <sub>o,set</sub> to 90%V <sub>o,set</sub>	All		10		ms

### EFFICIENCY

PARAMETER	NOTES and CONDITIONS	Device	Min.	Typical	Max.	Units
100% Load	V <sub>in</sub> =Nominal V <sub>in</sub> , T <sub>c</sub> =25°C	Vo=5.0V Vo=12V Vo=15V Vo=24V Vo=28V Vo=48V		91 92 90 90 90 89		%



# CQB60W-110S 60W Isolated DC-DC Converters

## Application Note V12 February 2018

### ISOLATION CHARACTERISTICS

PARAMETER	NOTES and CONDITIONS	Device	Min.	Typical	Max.	Units
Isolation Voltage	1 minute; input/output, input/case,	All			3000	V <sub>dc</sub>
	1 minute; output/case	All			1500	
Isolation Resistance		All	10			MΩ
Isolation Capacitance		All		1000		pF

### FEATURE CHARACTERISTICS

PARAMETER	NOTES and CONDITIONS	Device	Min.	Typical	Max.	Units
Switching Frequency		All		200		KHz
On/Off Control, Positive Remote On/Off logic						
Logic Low (Module Off)	V <sub>on/off</sub> at I <sub>on/off</sub> =1.0mA	All	0		1.2	V
Logic High (Module On)	V <sub>on/off</sub> at I <sub>on/off</sub> =0.0uA	All	3.5 or Open Circuit		75	V
On/Off Control, Negative Remote On/Off logic						
Logic High (Module Off)	V <sub>on/off</sub> at I <sub>on/off</sub> =0.0uA	All	3.5 or Open Circuit		75	V
Logic Low (Module On)	V <sub>on/off</sub> at I <sub>on/off</sub> =1.0mA	All	0		1.2	V
On/Off Current (for both remote on/off logic)	I <sub>on/off</sub> at V <sub>on/off</sub> =0.0V	All		0.3	1	mA
Leakage Current (for both remote on/off logic)	Logic High, V <sub>on/off</sub> =15V	All			30	uA
Off Converter Input Current	Shutdown input idle current	All		2	5	mA
Output Voltage Trim Range	P <sub>out</sub> =max rated power	All	-10		+10	%
Output Over Voltage Protection		All	115	125	140	%
Over-Temperature Shutdown		All		110		°C

### GENERAL SPECIFICATIONS

PARAMETER	NOTES and CONDITIONS	Device	Min.	Typical	Max.	Units
MTBF	I <sub>o</sub> =100% of I <sub>o,max</sub> ; T <sub>a</sub> =25°C per MIL-HDBK-217F	All		650		K hours
Weight		All		61.5		grams
Safety	UL60950-1 2 <sup>nd</sup> (Basic Insulation) Approval					
EMC (see Item 7.2)	EN50121-3-2 (with External Filter)					
EMI (with External Filter)	EN55022 Class B					
	EN55011 Class A					
ESD	EN61000-4-2 Air ±8KV Perf. Criteria A					
	EN61000-4-2 Contact ±6KV Perf. Criteria A					
Radiated Immunity	EN61000-4-3 20V/m Perf. Criteria A					
Fast Transient	EN61000-4-4 ±2KV Perf. Criteria A					
Surge	EN61000-4-5 ±1KV Perf. Criteria B					
Conducted Immunity	EN61000-4-6 10Vr.m.s Perf. Criteria A					
Shock/Vibration	Meets EN61373, MIL-STD-810F					
Humidity	95% RH max. Non Condensing					



# CQB60W-110S 60W Isolated DC-DC Converters

## Application Note V12 February 2018

### 5. Main Features and Functions

#### 5.1 Operating Temperature Range

The CQB60W-110S series converters can be operated within a wide case temperature range of  $-40^{\circ}\text{C}$  to  $105^{\circ}\text{C}$ . Consideration must be given to the derating curves when ascertaining maximum power that can be drawn from the converter. The maximum power drawn from open half brick models is influenced by usual factors, such as:

- Input voltage range
- Output load current
- Forced air or natural convection

#### 5.2 Output Voltage Adjustment

Section 6.8 describes in detail how to trim the output voltage with respect to its set point. The output voltage on all models is adjustable within the range of  $+10\%$  to  $-10\%$ .

#### 5.3 Over Current Protection

All models have internal over current and continuous short circuit protection. The unit operates normally once the fault condition is removed. At the point of current limit inception, the converter will go into hiccup mode protection.

#### 5.4 Output Overvoltage Protection

The output overvoltage protection consists of circuitry that internally limits the output voltage. If more accurate output over voltage protection is required then an external circuit can be used via the remote on/off pin.

#### 5.6 Remote On/Off

The CQB60W-110S series allows the user to switch the module on and off electronically with the remote on/off feature. All models are available in "positive logic" and "negative logic" (optional) versions. The converter turns on if the remote on/off pin is high ( $>3.5\text{Vdc}$  or open circuit). Setting the pin low (0 to  $<1.2\text{Vdc}$ ) will turn the converter off. The signal level of the remote on/off input is defined with respect to ground. If not using the remote on/off pin, leave the pin open (converter will be on). Models with part number suffix "N" are the "negative logic" remote on/off version. The unit turns off if the remote on/off pin is high ( $>3.5\text{Vdc}$  or open circuit). The converter turns on if the on/off pin input is low (0 to  $<1.2\text{Vdc}$ ). Note that the converter is off by default.

#### 5.7 UVLO (Under voltage Lock Out)

Input under voltage lockout is standard on the CQB60W-110S unit. The unit will shut down when the input voltage drops below a threshold, and the unit will operate when the input voltage goes above the upper threshold.

### 5.8 Over Temperature Protection

These modules have an over temperature protection circuit to safeguard against thermal damage. Shutdown occurs with the maximum case reference temperature is exceeded. The module will restart when the case temperature falls below over temperature shutdown threshold.

## 6. Applications

### 6.1 Recommended Layout, PCB Footprint and Soldering Information

The system designer or end user must ensure that metal and other components in the vicinity of the converter meet the spacing requirements for which the system is approved. Low resistance and inductance PCB layout traces are the norm and should be used where possible. Due consideration must also be given to proper low impedance tracks between power module, input and output grounds. The recommended soldering profile and PCB layout are shown below.

Lead Free Wave Soldering Profile

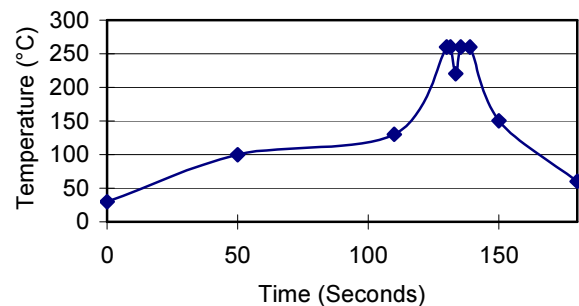

Note :

1. Soldering Materials: Sn/Cu/Ni
2. Ramp up rate during preheat:  $1.4^{\circ}\text{C}/\text{Sec}$  (From  $50^{\circ}\text{C}$  to  $100^{\circ}\text{C}$ )
3. Soaking temperature:  $0.5^{\circ}\text{C}/\text{Sec}$  (From  $100^{\circ}\text{C}$  to  $130^{\circ}\text{C}$ ),  $60\pm 20$  seconds
4. Peak temperature:  $260^{\circ}\text{C}$ , above  $250^{\circ}\text{C}$  3~6 Seconds
5. Ramp up rate during cooling:  $-10.0^{\circ}\text{C}/\text{Sec}$  ( From  $260^{\circ}\text{C}$  to  $150^{\circ}\text{C}$  )

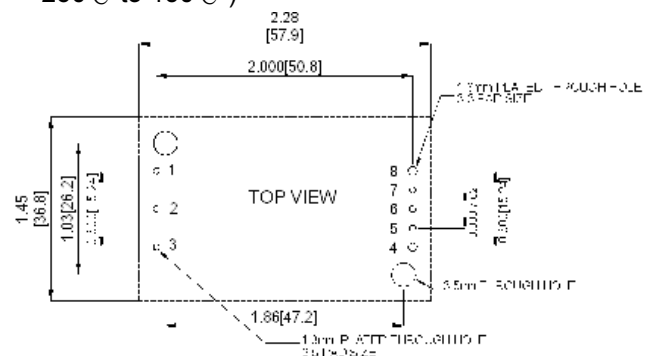



## CQB60W-110S 60W Isolated DC-DC Converters Application Note V12 February 2018

---

### **6.2 Convection Requirements for Cooling**

To predict the approximate cooling needed for the Quarter brick module, refer to the power derating curves in section 6.4. These derating curves are approximations of the ambient temperatures and airflows required to keep the power module temperature below its maximum rating. Once the module is assembled in the actual system, the module's temperature should be monitored to ensure it does not exceed 100°C as measured at the center of the top of the case (thus verifying proper cooling).

### **6.3 Thermal Considerations**

The power module operates in a variety of thermal environments; however, sufficient cooling should be provided to help ensure reliable operation of the unit. Heat is removed by conduction, convection, and radiation to the surrounding environment. The example is presented in section 6.4. The power output of the module should not be allowed to exceed rated power ( $V_{o\_set} \times I_{o\_max}$ ).

The power modules have through-threaded, M3 x0.5 mounting holes, which enable heat sinks or cold plates to be attached to the module. Thermal de-rating with heat sinks is expressed by using the overall thermal resistance of the module ( $R_{ca}$ )



# CQB60W-110S 60W Isolated DC-DC Converters

## Application Note V12 February 2018

### 6.4 Power Derating

The operating case temperature range of CQB60W-110S series is -40°C to +105°C. When operating the CQB60W-110S series, proper derating or cooling is needed. The maximum case temperature under any operating condition should not exceed 105°C.

Forced Convection Power De-rating without Heat Sink

**Example (without heatsink):**

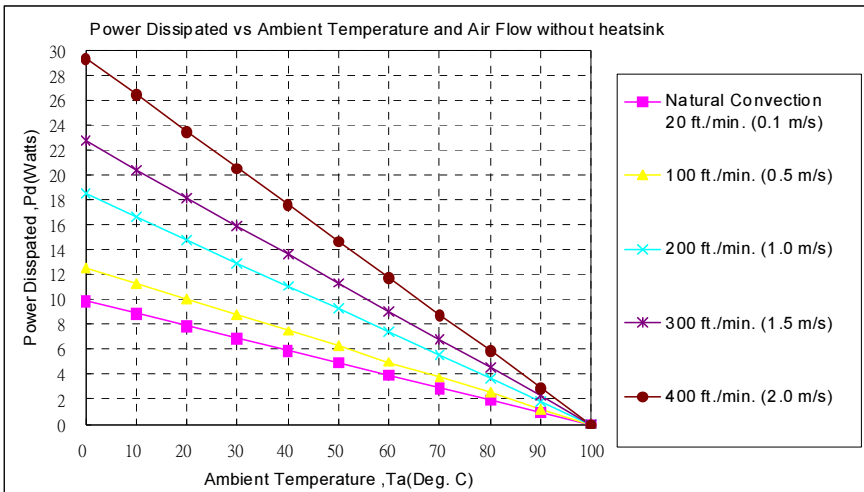

AIR FLOW RATE	TYPICAL R <sub>ca</sub>
Natural Convection 20ft./min. (0.1m/s)	10.1 °C/W
100 ft./min. (0.5m/s)	8.0 °C/W
200 ft./min. (1.0m/s)	5.4 °C/W
300 ft./min. (1.5m/s)	4.4 °C/W
400 ft./min. (2.0m/s)	3.4 °C/W

What is the minimum airflow necessary for a CQB60W-110S05 operating at nominal line voltage, an output current of 12A, and a maximum ambient temperature of 50°C?

**Solution:**

**Given:**

$$V_{in}=110V_{dc}, V_o=5V_{dc}, I_o=12A$$

**Determine Power dissipation (P<sub>d</sub>):**

$$P_d = P_i - P_o = P_o(1-\eta)/\eta$$

$$P_d = 5 \times 12 \times (1-0.91)/0.91 = 5.93 \text{ Watts}$$

**Determine airflow:**

$$\text{Given: } P_d = 5.93W \text{ and } T_a = 50^\circ C$$

**Check Power Derating curve:**

Minimum airflow = 100 ft./min.

**Verify:**

Maximum temperature rise is

$$\Delta T = P_d \times R_{ca} = 5.93W \times 8.0 = 47.44^\circ C.$$

Maximum case temperature is

$$T_c = T_a + \Delta T = 97.44^\circ C < 105^\circ C.$$

**Where:**

The R<sub>ca</sub> is thermal resistance from case to ambient environment.

T<sub>a</sub> is ambient temperature and T<sub>c</sub> is case temperature.



# CQB60W-110S 60W Isolated DC-DC Converters Application Note V12 February 2018

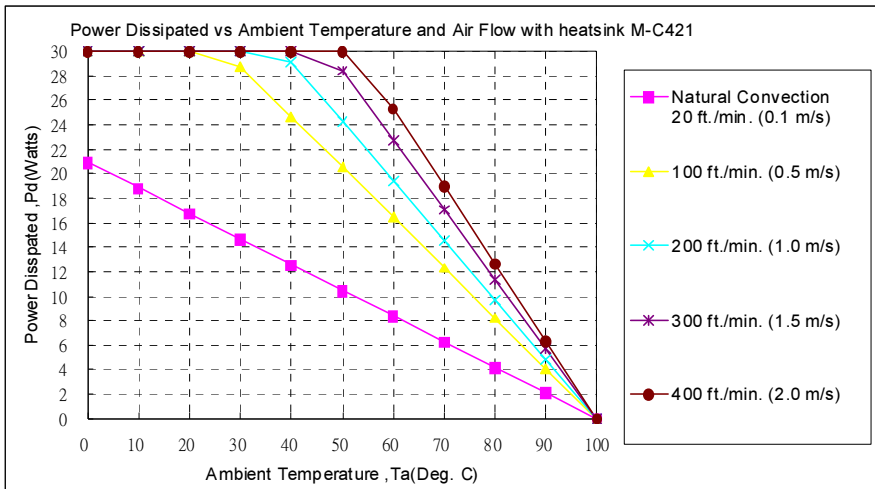

AIR FLOW RATE	TYPICAL $R_{ca}$
Natural Convection 20ft./min. (0.1m/s)	4.78 °C/W
100 ft./min. (0.5m/s)	2.44 °C/W
200 ft./min. (1.0m/s)	2.06 °C/W
300 ft./min. (1.5m/s)	1.76 °C/W
400 ft./min. (2.0m/s)	1.58 °C/W

Example (with heatsink M-C421):

What is the minimum airflow necessary for a CQB60W-110S12 operating at nominal line voltage, an output current of 5A, and a maximum ambient temperature of 60°C ?

**Solution:**

**Given:**

$$V_{in}=110V_{dc}, V_o=12V_{dc}, I_o=5A$$

**Determine Power dissipation ( $P_d$ ):**

$$P_d=P_i-P_o=P_o(1-\eta)/\eta$$

$$P_d=12 \times 5 \times (1-0.92)/0.92=5.22 \text{ Watts}$$

**Determine airflow:**

Given:  $P_d=5.22W$  and  $T_a=60^\circ C$

**Check above Power de-rating curve:**

$P_d < 8.4W$ , Natural Convection

**Verify:**

Maximum temperature rise is

$$\Delta T = P_d \times R_{ca} = 5.22 \times 4.78 = 24.95^\circ C$$

Maximum case temperature is  $T_c = T_a + \Delta T = 84.95^\circ C < 105^\circ C$

**Where:**

The  $R_{ca}$  is thermal resistance from case to ambient environment.

$T_a$  is ambient temperature and  $T_c$  is case temperature.



# CQB60W-110S 60W Isolated DC-DC Converters Application Note V12 February 2018

## 6.5 Quarter Brick Heat Sinks:

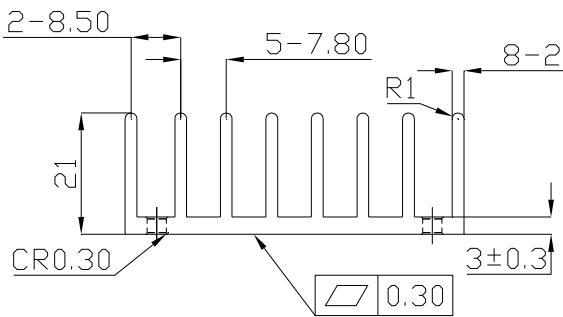
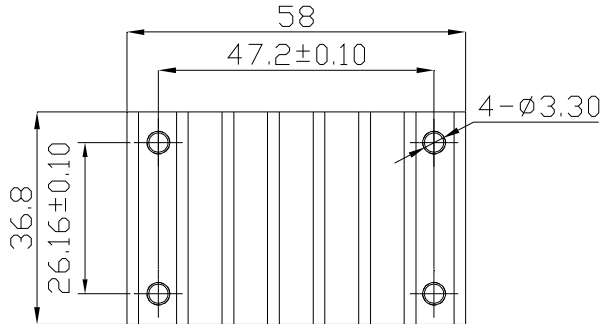

**M-C421 (G6620510201)**  
**Transverse Heat Sink**

All Dimensions in mm

Rca: 4.78°C/W (typ.), At natural convection  
2.44°C/W (typ.), At 100LFM  
2.06°C/W (typ.), At 200LFM  
1.76°C/W (typ.), At 300LFM  
1.58°C/W (typ.), At 400LFM

THERMAL PAD: SZ 35.8\*56.9\*0.25 mm (G6135041041)  
SCREW: SMP+SW M3\*8L (G75A1300322)

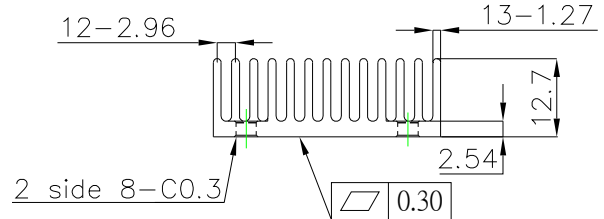
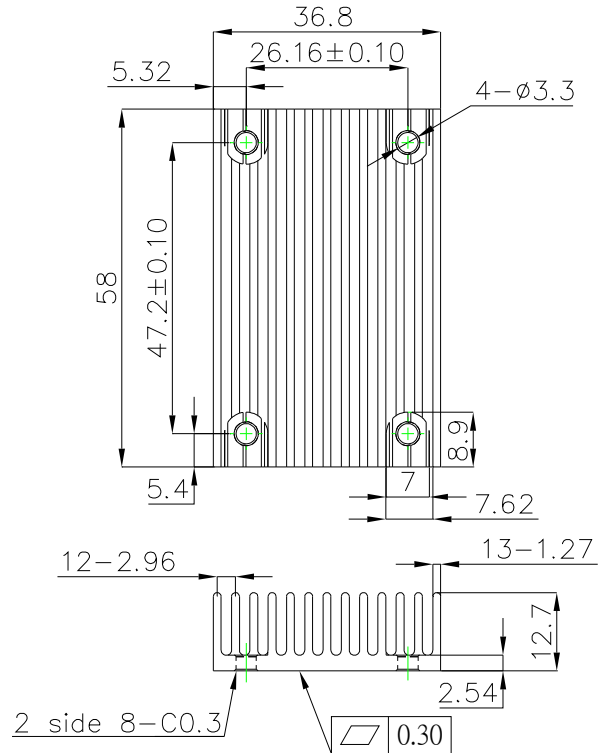

**M-C448 (G6620570202)**  
**Longitudinal Heat Sink**

Rca: 5.61°C/W (typ.), At natural convection  
4.01°C/W (typ.), At 100LFM  
3.39°C/W (typ.), At 200LFM  
2.86°C/W (typ.), At 300LFM  
2.49°C/W (typ.), At 400LFM



# CQB60W-110S 60W Isolated DC-DC Converters Application Note V12 February 2018

## 6.6 Efficiency VS. Load

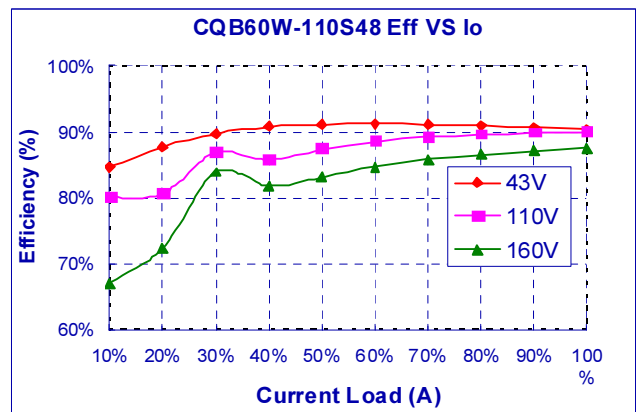
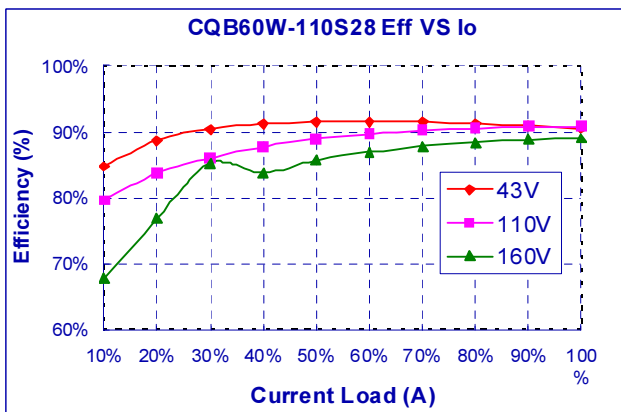
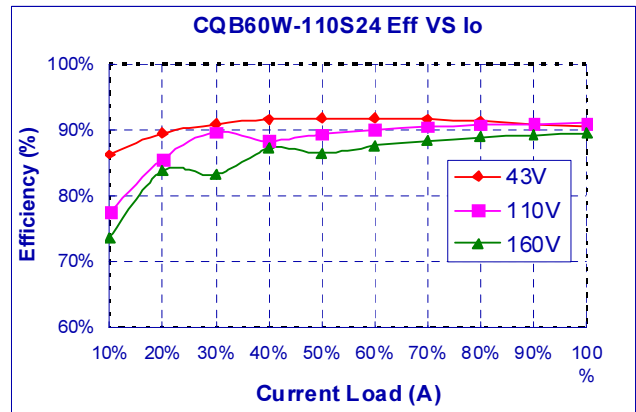
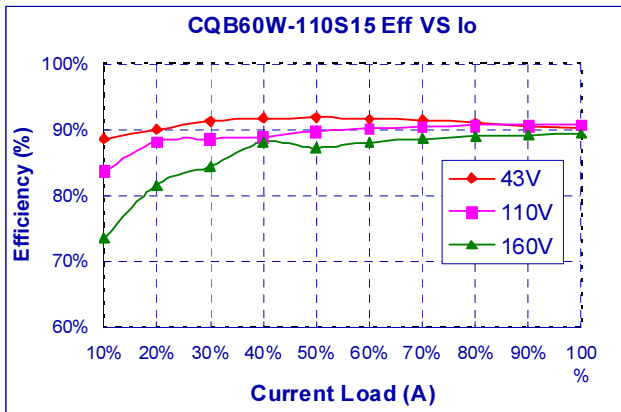
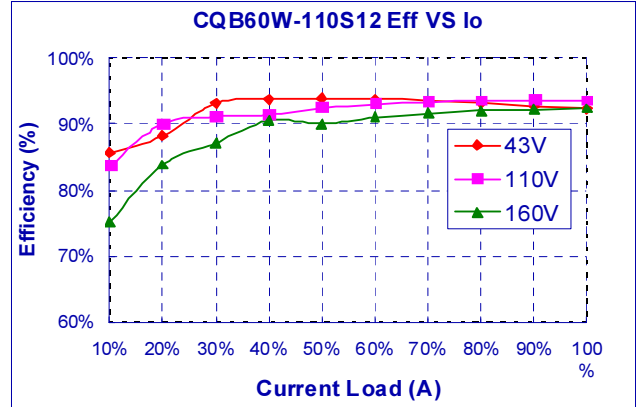
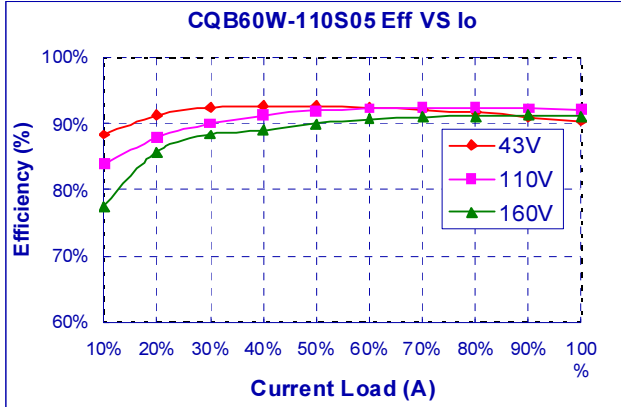



# CQB60W-110S 60W Isolated DC-DC Converters Application Note V12 February 2018

## 6.7 Test Set-Up

The basic test set-up to measure parameters such as efficiency and load regulation is shown below. When testing the modules under any transient conditions please ensure that the transient response of the source is sufficient to power the equipment under test. We can calculate:

- Efficiency
- Load regulation and line regulation.

The value of efficiency is defined as:

$$\eta = \frac{V_o \times I_o}{V_{in} \times I_{in}} \times 100\%$$

Where:

$V_o$  is output voltage,  
 $I_o$  is output current,  
 $V_{in}$  is input voltage,  
 $I_{in}$  is input current.

The value of load regulation is defined as:

$$\text{Load.reg} = \frac{V_{FL} - V_{NL}}{V_{NL}} \times 100\%$$

Where:

$V_{FL}$  is the output voltage at full load  
 $V_{NL}$  is the output voltage at no load

The value of line regulation is defined as:

$$\text{Line.reg} = \frac{V_{HL} - V_{LL}}{V_{LL}} \times 100\%$$

Where:

$V_{HL}$  is the output voltage of maximum input voltage at full load.  
 $V_{LL}$  is the output voltage of minimum input voltage at full load.

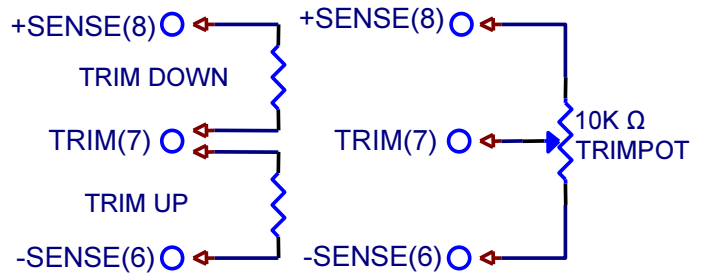

In order to trim the voltage up or down, one needs to connect the trim resistor either between the trim pin and  $-V_o$  for trim-up or between trim pin and  $+V_o$  for trim-down. The output voltage trim range is  $\pm 10\%$ . This is shown:

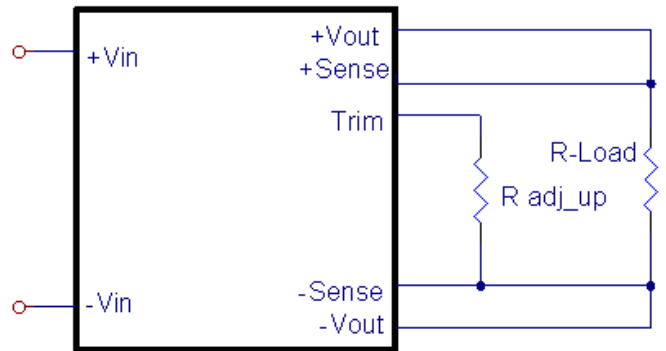

Trim-up Voltage Setup

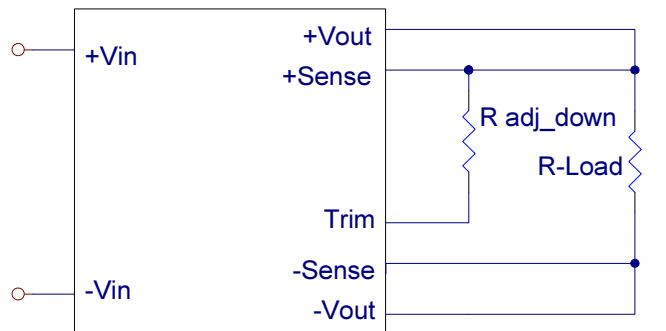

Trim-down Voltage Setup

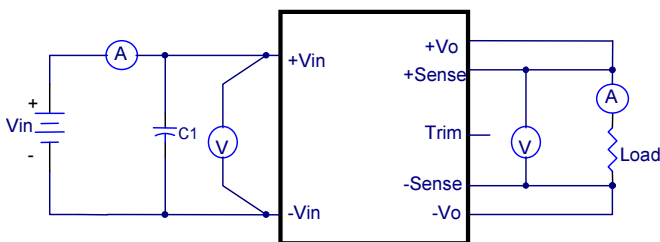

CQB60W-110S Series Test Setup

## 6.8 Output Voltage Adjustment

Output may be externally trimmed ( $\pm 10\%$ ) with a fixed resistor or an external trim pot as shown (optional). Model specific formulas for calculating trim resistors are available upon request as a separate document.

$V_{out}$ (V)	A	B	C	D
5V	2.32	0	4.75	4.75
12V	9.1	0.4	5.8	39
15V	12	0.42	6.1	56
24V	20	0.44	6.4	100
28V	23.7	0.44	6.5	120
48V	43.2	0.46	6.6	240

Trim Resistor Values

The value of  $R_{trim\_up}$  defined as:

$$R_{trim\_up} = \frac{A \times (2.5 - B)}{V_o - V_{o\_nom}} - C \quad (\text{K}\Omega)$$



# CQB60W-110S 60W Isolated DC-DC Converters

## Application Note V12 February 2018

Where:

- $R_{trim\_up}$  is the external resistor in  $K\Omega$ .
- $V_{o\_nom}$  is the nominal output voltage.
- $V_o$  is the desired output voltage.
- A, B and C are internal components.

For example, to trim-up the output voltage of 12V module (CQB60W-110S12) by 5% to 12.6V,  $R_{trim\_up}$  is calculated as follows:

$$\begin{aligned} V_o - V_{o\_nom} &= 12.6 - 12 = 0.6V \\ A &= 9.1 \\ B &= 0.4 \\ C &= 5.8 \end{aligned}$$

$$R_{trim\_up} = \frac{9.1 \times (2.5 - 0.4)}{0.6} - 5.8 = 26.05 \text{ (K}\Omega\text{)}$$

The value of  $R_{trim\_down}$  defined as:

$$R_{trim\_down} = \frac{A \times (V_o - 2.5)}{V_{o\_nom} - V_o} - D \text{ (K}\Omega\text{)}$$

Where:

- $R_{trim\_down}$  is the external resistor in  $K\Omega$ .
- $V_{o\_nom}$  is the nominal output voltage.
- $V_o$  is the desired output voltage.
- A and D are internal components.

For example: to trim-down the output voltage of 12V module (CQB60W-110S12) by 5% to 11.4V,  $R_{trim\_down}$  is calculated as follows:

$$\begin{aligned} V_{o\_nom} - V_o &= 12 - 11.4 = 0.6V \\ A &= 9.1 \\ D &= 39 \end{aligned}$$

$$R_{trim\_down} = \frac{9.1 \times (11.4 - 2.5)}{0.6} - 39 = 95.98 \text{ (K}\Omega\text{)}$$

### 6.9 Output Remote Sensing

The CQB60W-110S series converter has the capability to remotely sense both lines of its output. This feature moves the effective output voltage regulation point from the output of the unit to the point of connection of the remote sense pins. This feature automatically adjusts the real output voltage of the CQB60W-110S series in order to compensate for voltage drops in distribution and maintain a regulated voltage at the point of load. The remote-sense voltage range is:  $[(+V_{out}) - (-V_{out})] - [(+Sense) - (-Sense)] \leq 10\%$  of  $V_{o\_nominal}$

If the remote sense feature is not to be used, the sense pins should be connected locally. The +Sense pin should be connected to the +Vout pin at the module and the -Sense pin should be connected to the -Vout pin at the module. This is shown in the schematic below.

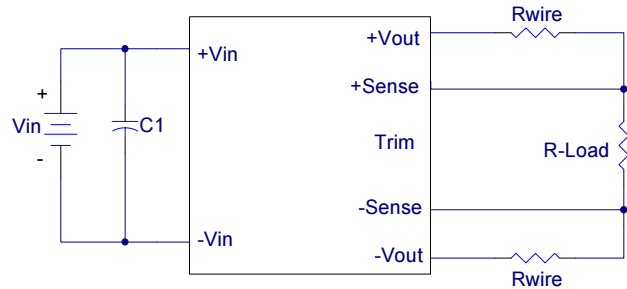

**Note:**

Although the output voltage can be varied (increased or decreased) by both remote sense and trim, the maximum variation for the output voltage is the larger of the two values not the sum of the values. The output power delivered by the module is defined as the voltage at the output terminals multiplied by the output current. Using remote sense and trim can cause the output voltage to increase and consequently increase the power output of the module if output current remains unchanged. Always ensure that the output power of the module remains at or below the maximum rated power. Also be aware that if  $V_{o\_set}$  is below nominal value,  $P_{out\_max}$  will also decrease accordingly because  $I_{o\_max}$  is an absolute limit. Thus,  $P_{out\_max} = V_{o\_set} \times I_{o\_max}$  is also an absolute limit.

### 6.10 Output Ripple and Noise

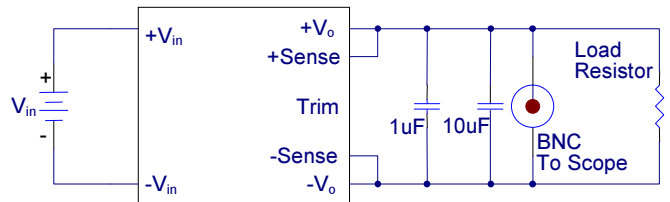

Output ripple and noise is measured with 10uF tantalum and 1uF ceramic capacitors across the output.

### 6.11 Output Capacitance

The CQB60W-110S series converters provide unconditional stability with or without external capacitors. For good transient response, low ESR output capacitors should be located close to the point of load. PCB design emphasizes low resistance and inductance tracks in consideration of high current applications. Output capacitors with their associated ESR values have an impact on loop stability and bandwidth. Cincon's converters are designed to work with load capacitance to see technical specifications.



# CQB60W-110S 60W Isolated DC-DC Converters Application Note V12 February 2018

## 7. Safety & EMC

### 7.1 Input Fusing and Safety Considerations

The CQB60W-110S series converters have no internal fuse. In order to achieve maximum safety and system protection, always use an input line fuse. We recommended a time delay fuse 2A,. It is recommended that the circuit have a transient voltage suppressor diode (TVS) across the input terminal to protect the unit against surge or spike voltage and input reverse voltage (as shown).

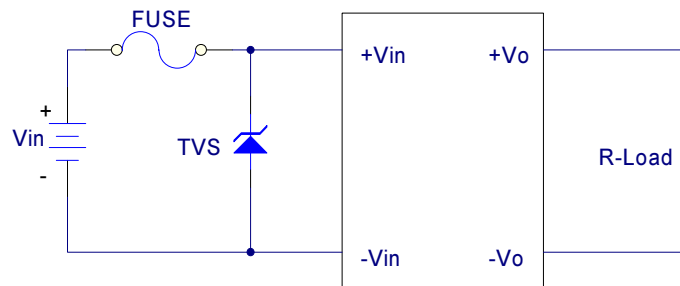

### 7.2 EMC Considerations

- (1) EMI Test standard: EN55022 Class B Conducted Emission  
Test Condition: Input Voltage: Nominal, Output Load: Full Load

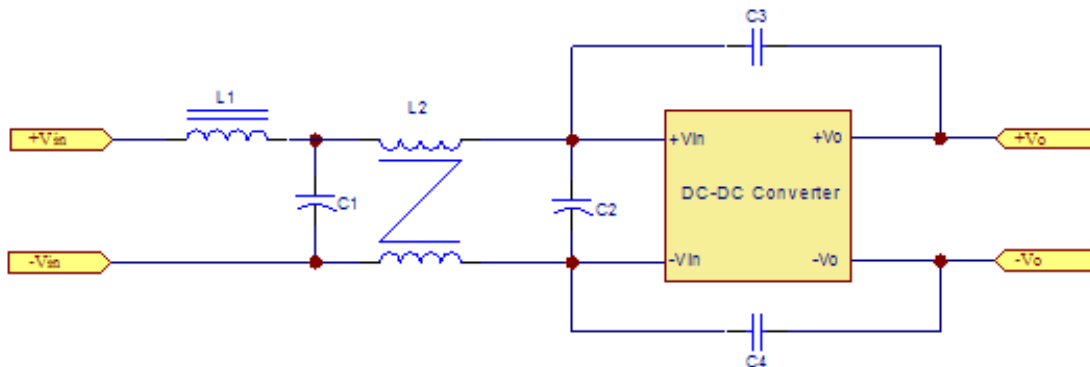

Model No.	C1	C2	C3	C4	L1	L2
CQB60W-110S05	220uF/200V YXF	220uF/200V YXF	2200pF	2200pF	38uH	1mH
CQB60W-110S12	220uF/200V YXF	220uF/200V YXF	2200pF	2200pF	38uH	1mH
CQB60W-110S15	220uF/200V YXF	220uF/200V YXF	2200pF	2200pF	38uH	1mH
CQB60W-110S24	220uF/200V YXF	220uF/200V YXF	2200pF	2200pF	Short Circuit	1mH
CQB60W-110S28	220uF/200V YXF	220uF/200V YXF	2200pF	2200pF	Short Circuit	1mH
CQB60W-110S48	220uF/200V YXF	220uF/200V YXF	2200pF	2200pF	Short Circuit	1mH

Note: C1, C2 Aluminum Capacitors and C3, C4 Ceramic Capacitors



# CQB60W-110S 60W Isolated DC-DC Converters Application Note V12 February 2018

EMI and conducted noise meet EN55022 Class B

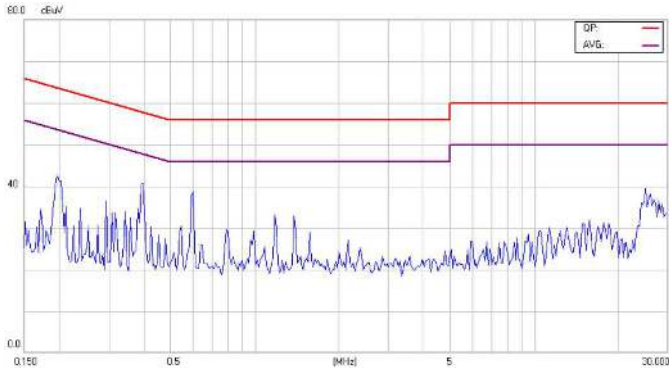

Conducted Class B of CQB60W-110S05

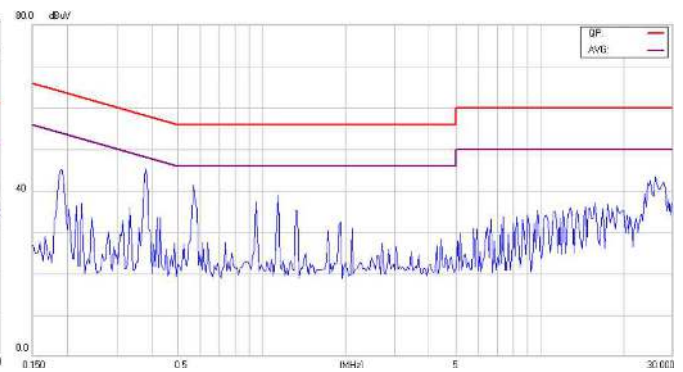

Conducted Class B of CQB60W-110S12

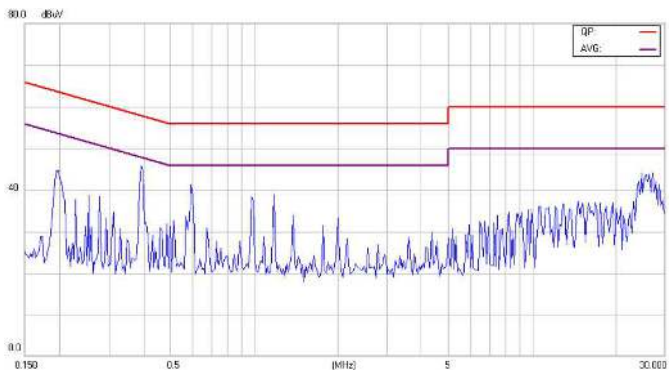

Conducted Class B of CQB60W-110S15

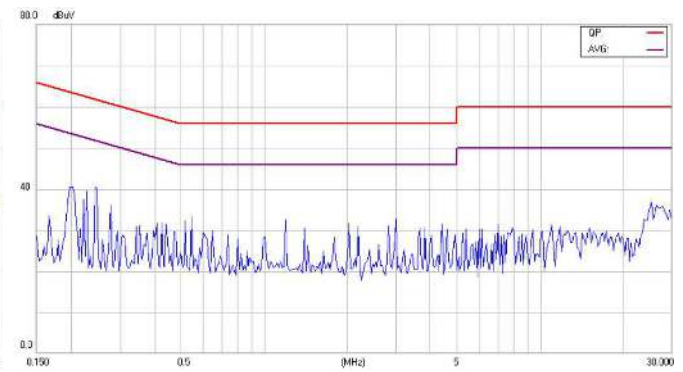

Conducted Class B of CQB60W-110S24

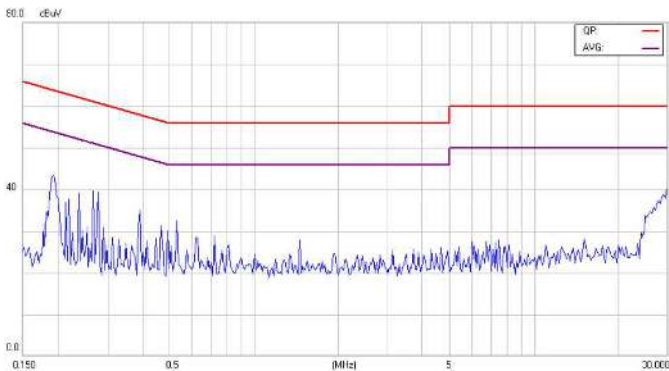

Conducted Class B of CQB60W-110S28

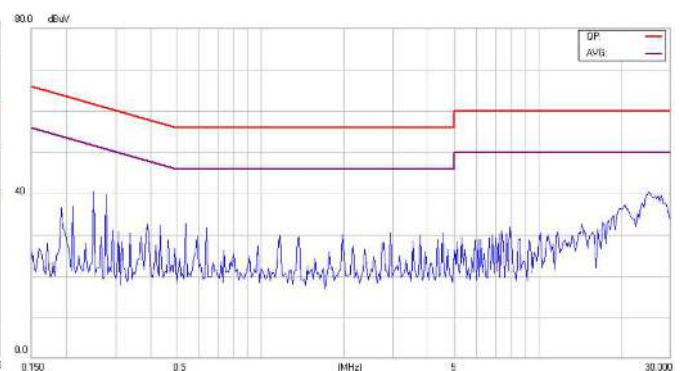

Conducted Class B of CQB60W-110S48



# CQB60W-110S 60W Isolated DC-DC Converters

## Application Note V12 February 2018

(2) EMI Test standard: EN50121-3-2 (EN55011 Class A Conducted & Radiated Emission )  
 Test Condition: Input Voltage: Nominal, Output Load: Full Load

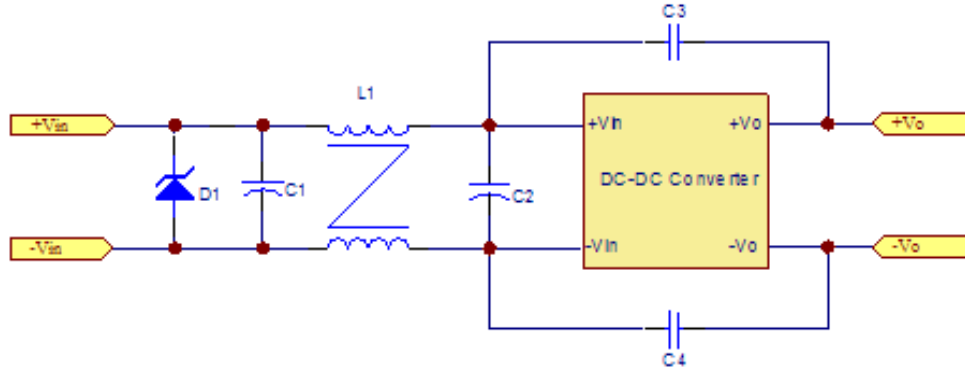

Model No.	D1	C1	C2	C3	C4	L1
CQB60W-110S Series	1.5KE180A Littelfuse	220uF/200V YXF	220uF/200V YXF	2200pF	2200pF	1mH

Note: C1, C2 Aluminum Capacitors and C3, C4 Ceramic Capacitors

EMI and conducted noise meet EN55011 Class A

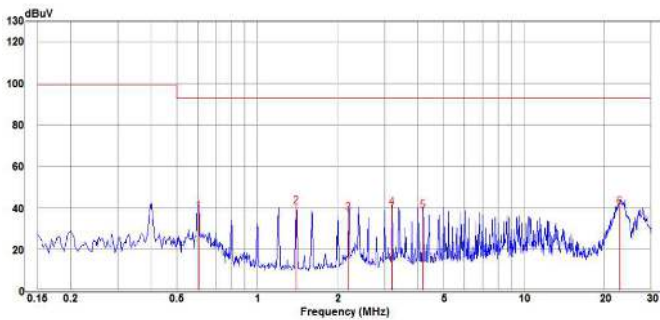

Conducted Class A of CQB60W-110S05

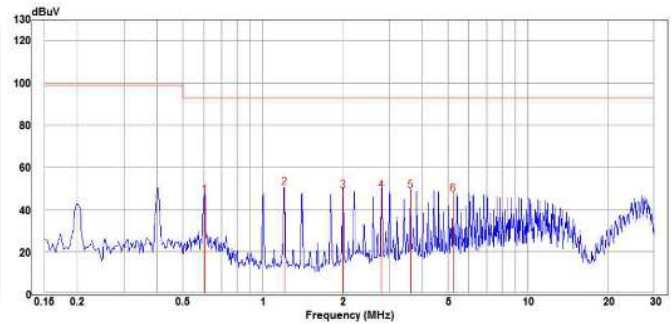

Conducted Class A of CQB60W-110S12

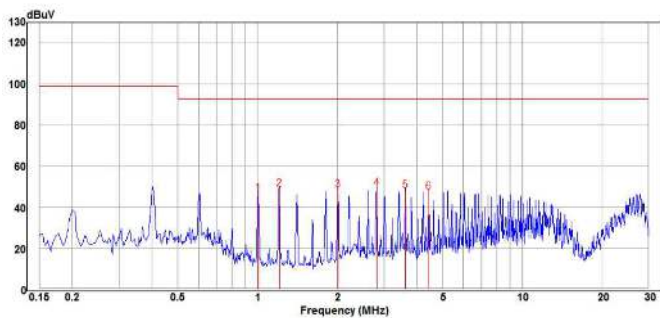

Conducted Class A of CQB60W-110S15

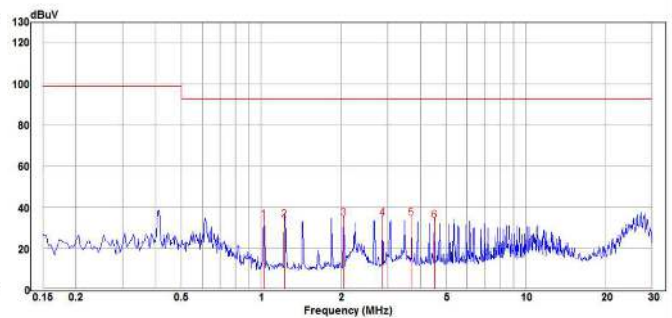

Conducted Class A of CQB60W-110S24

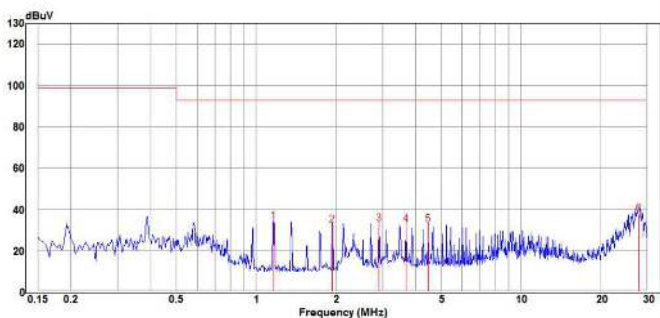

Conducted Class A of CQB60W-110S28

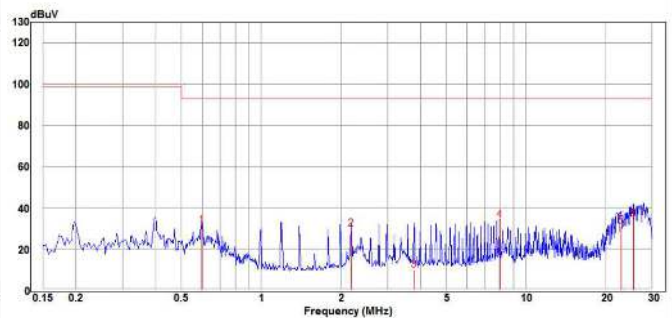

Conducted Class A of CQB60W-110S48





# CQB60W-110S 60W Isolated DC-DC Converters Application Note V12 February 2018

## 9. Mechanical Specifications

### 9.1 Mechanical Outline Diagrams

CASE QB

All Dimensions In Inches(mm)

Tolerances Inches: X.XX= ±0.02 , X.XXX= ±0.010

Millimeters: X.X= ±0.5 , X.XX=±0.25

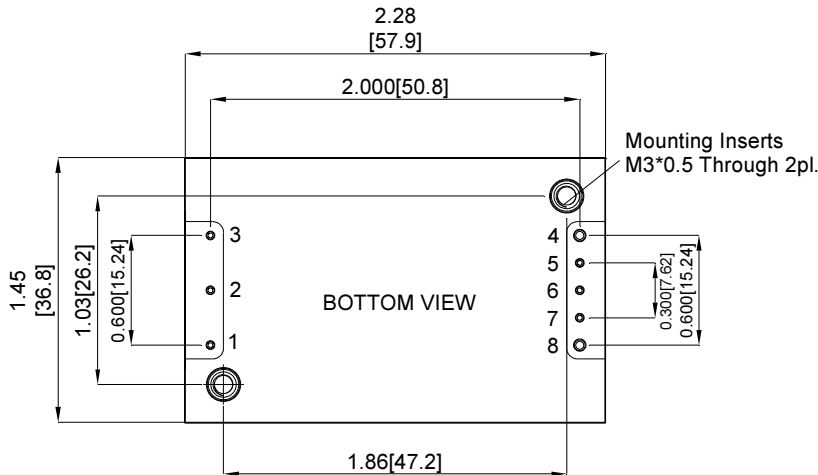

Pin	Function
1	+V Input
2	On/Off
3	-V Input
4	-V Output
5	-Sense
6	Trim
7	+Sense
8	+V Output

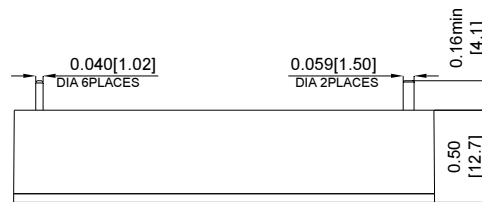

### CINCON ELECTRONICS CO., LTD.

#### Headquarters:

14F, No.306, Sec.4, Hsin Yi Rd.  
Taipei, Taiwan  
Tel: 886-2-27086210  
Fax: 886-2-27029852  
E-mail: [support@cincon.com.tw](mailto:support@cincon.com.tw)  
Web Site: <http://www.cincon.com>

#### Factory:

No. 8-1, Fu Kung Rd.  
Fu Hsing Industrial Park  
Fu Hsing Hsiang,  
Chang Hua Hsien, Taiwan  
Tel: 886-4-7690261  
Fax: 886-4-7698031

#### Cincon North America:

1655 Mesa Verde Ave. Ste 180  
Ventura, CA 93003  
Tel: 805-639-3350  
Fax: 805-639-4101  
E-mail: [info@cincon.com](mailto:info@cincon.com)