



CQB100W Series Application Note V12 February 2012

ISOLATED DC-DC CONVERTER CQB100W SERIES APPLICATION NOTE



Approved By:

Department	Approved By	Checked By	Written By
Research and Development Department	Enoch	Danny	David
Quality Assurance Department	Jack	Benny	



CQB100W Series

Application Note V12 February 2012

Contents

1. Introduction	3
2. DC-DC Converter Features.....	3
3. Electrical Block Diagram	3
4. Technical Specifications.....	4
4.1 Absolute Maximum Ratings	4
4.2 Electrical Specifications.....	4
4.3 Isolation Specifications	6
4.4 Feature Specifications	6
5. Main Features and Functions.....	7
5.1 Operating Temperature Range.....	7
5.2 Output Voltage Adjustment.....	7
5.3 Over Current Protection.....	7
5.4 Output Overvoltage Protection.....	7
5.6 Remote ON/OFF	7
5.7 UVLO (Undervoltage Lock Out).....	7
5.8 Over Temperature Protection	7
6. Applications.....	7
6.1 Recommended Layout, PCB Footprint and Soldering Information.....	7
6.2 Convection Requirements for Cooling	8
6.3 Thermal Considerations.....	8
6.4 Power Derating.....	8
6.5 Quarter Brick Heat Sinks:	10
6.6 Efficiency VS. Load	11
6.7 Test Set-Up.....	13
6.8 Output Voltage Adjustment.....	13
6.9 Output Remote Sensing	14
6.10 Output Ripple and Noise.....	14
6.11 Output Capacitance.....	14
7. Safety & EMC.....	15
7.1 Input Fusing and Safety Considerations	15
7.2 EMC Considerations.....	15
8. Part Number.....	17
9. Mechanical Specifications	17
9.1 Mechanical Outline Diagrams.....	17



CQB100W Series

Application Note V12 February 2012

1. Introduction

This specification describes the features and functions of Cincon's CQB100W series of isolated DC-DC Converters. These are highly efficient, reliable and compact, high power density, single output DC/DC converters. The modules can be used in the field of telecommunications, data communications, wireless communications, servers etc. The CQB100W series can deliver up to 30A output current and provide a precisely regulated output voltage over a wide range of input voltages ($V_i=9-36V_{dc}$ or $V_i=18-75V_{dc}$). The modules can achieve high efficiency up to 88%. The module offers direct cooling of dissipative components for excellent thermal performance. Standard features include remote On/Off, remote sense, output voltage adjustment, over voltage, over current and over temperature protection. The CQB100W series also have the following options: remote On/Off (positive or negative).

2. DC-DC Converter Features

- 100W Isolated Output
- Efficiency (at full load) up to 88%
- Regulated Output
- Fixed Switching Frequency
- Input Under Voltage Lockout Protection
- Over Current Protection
- Remote ON/OFF
- Continuous Short Circuit Protection
- Industry Standard Quarter-Brick Package
- Fully Isolated to 1500VDC

3. Electrical Block Diagram

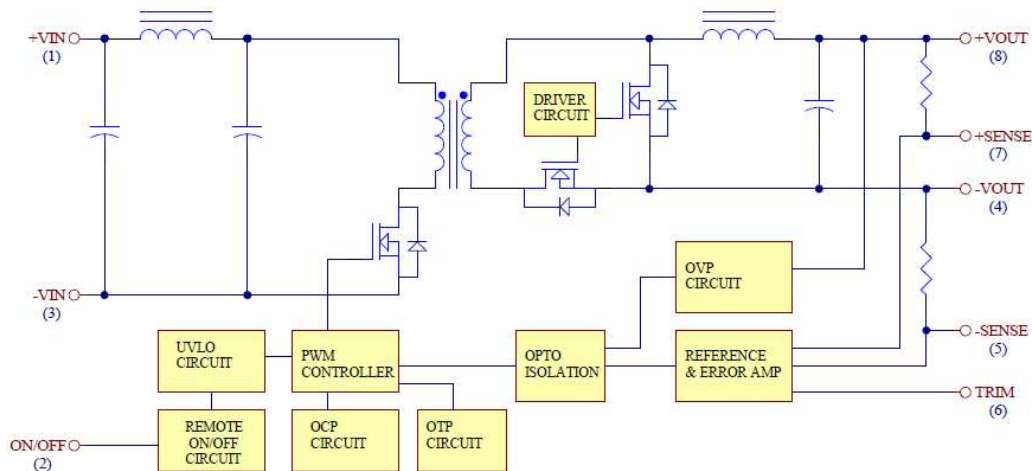

Electrical Block Diagram for 5Vout and 3.3Vout

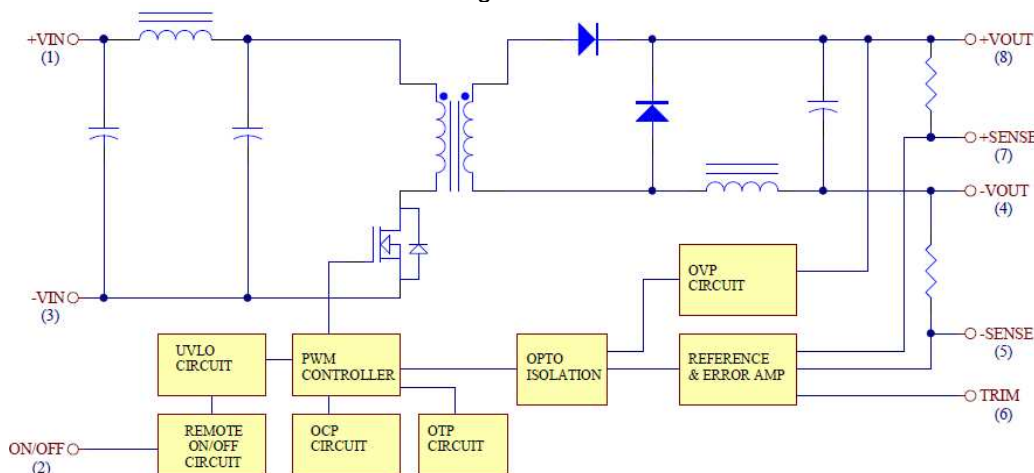

Electrical Block Diagram for other modules



CQB100W Series

Application Note V12 February 2012

4. Technical Specifications

(All specifications are typical at nominal input, full load at 25°C unless otherwise noted.)

4.1 Absolute Maximum Ratings

Stresses in excess of the absolute maximum ratings can cause permanent damage to the device. These are absolute stress ratings only, functional operation of the device is not implied at these or any other conditions in excess of those given in the operations sections of the data sheet. Exposure to absolute maximum ratings for extended periods can adversely affect the device reliability.

Parameter	Device	Symbol	Min	Typ	Max	Unit
Input Voltage						
Continuous	24SXX	V_{IN}	-0.3		36	Vdc
	48SXX		-0.3		75	
Transient (100ms)	24SXX	$V_{IN,trans}$			50	Vdc
	48SXX				100	
Operating case Temperature (Note 1)	All	T_{CASE}	-40		100	°C
Storage Temperature	All	T_{stg}	-40		105	°C
I/O Isolation Voltage	All	—	—	1500	—	Vdc
Note1: see de-rating curve for application						

4.2 Electrical Specifications

Input Specifications

Parameter	Device	Symbol	Min	Typ	Max	Unit
Operating Input Voltage	24SXX	V_{IN}	9.0	24.0	36.0	Vdc
	48SXX		18.0	48.0	75.0	
Input Under-Voltage Lockout						
Turn-On Voltage Threshold	24SXX	$V_{IN(on)}$	8.0	8.8	9.0	Vdc
	48SXX		16.0	17.0	18.0	
Turn-Off Voltage Threshold	24SXX	$V_{IN(off)}$	7.5	8.0	8.5	Vdc
	48SXX		15.0	16.0	17.0	
Maximum Input Current						
100% Load, 9 Vin, trim up 100% Load, 18 Vin, trim up	24SXX	$I_{IN,max}$			14.2	A
	48SXX				10.8	
Input Ripple Current, Peak-to-Peak(Note1)	24SXX	$I_{IN,p-p}$			30	mA
	48SXX				50	
Input No Load Current (V_{in} =Nominal Input Voltage)	24S3V3,05	$I_{IN,No Load}$		120		mA
	24S12,15,24			80		mA
	48S3V3,05			60		mA
	48S12,15,24			30		mA
Input Standby Current	All	$I_{IN,standby}$			10	mA
Inrush Transient	24SXX	I^2t			1.0	A ² s
	48SXX				0.5	
Recommended Input Fuse (Note 2)	24SXX				20	A
	48SXX				15	
Input Capacitance (External) (Note 3)	24SXX			100		µF
	48SXX			47		

Notes: Note1: 5Hz to 20MHz, 12µH source impedance; $V_{IN}=V_{IN,min}$ to $V_{IN,max}$, $I_o=I_{o,max}$; test setup see Fig.1.
 Note2: Slow Blow/Antisurge HRC recommended 200V Rating.
 Note 3: Recommended customer added capacitance, <0.7Ω ESR.



CQB100W Series

Application Note V12 February 2012

Output Specifications

Parameter	Device	Symbol	Min	Typ	Max	Units
Output Voltage Set-point	3.3V _{dc}	V _{o,set}	3.25	3.3	3.35	V _{dc}
	5V _{dc}	V _{o,set}	4.92	5	5.08	V _{dc}
	12V _{dc}	V _{o,set}	11.82	12	12.18	V _{dc}
	15V _{dc}	V _{o,set}	14.77	15	15.23	V _{dc}
	24V _{dc}	V _{o,set}	23.64	24	24.36	V _{dc}
Output Voltage Regulation:						
Line (low line to high line)	All		—	—	0.2	% V _o ,
Load (I _o =I _{o,min} to I _{o,max})	All		—	—	0.2	nom
Temperature Coefficient	All				±0.03	%/°C
Output Ripple and Noise (Note1)						
Peak-to-Peak (5Hz to 20MHz bandwidth)	3.3~5V				100	mV
	12~15V				150	
	24V				240	
RMS (5Hz to 20MHz bandwidth)	3.3~5V				40	mV
	12~15V				60	
	24V				100	
Output Voltage Trim Range	All	V _{o,trim}	-10	—	10	% V _o , nom
Remote-sense Compensation	All				10	% V _o , nom
Output Current	3.3 V _{dc}	I _o	0	—	30.0	A _{dc}
	5.0 V _{dc}	I _o	0	—	20.0	A _{dc}
	12 V _{dc}	I _o	0	—	8.30	A _{dc}
	15 V _{dc}	I _o	0	—	6.70	A _{dc}
	24 V _{dc}	I _o	0	—	4.17	A _{dc}
Output Current Limit Inception (V _o = 90% of V _o , set) Hiccup mode 110%-160%	3.3 V _{dc}	I _{o,lim}	33	40	48	A _{dc}
	5.0 V _{dc}	I _{o,lim}	22	27	32	A _{dc}
	12 V _{dc}	I _{o,lim}	9.13	11.2	13.28	A _{dc}
	15 V _{dc}	I _{o,lim}	7.37	9	10.72	A _{dc}
	24 V _{dc}	I _{o,lim}	4.59	5.62	6.67	A _{dc}
Efficiency (V _{IN} = Nominal Voltage; I _o = I _{o,max} ; T _A = 25 °C)	24S3V3	η	—	86	—	%
	24S05	η	—	86.5	—	
	24S12	η	—	86.5	—	
	24S15	η	—	86.5	—	
	24S24	η	—	87	—	
	48S3V3	η	—	88	—	
	48S05	η	—	88	—	
	48S12	η	—	88	—	
	48S15	η	—	88	—	
	48S24	η	—	88	—	
Output Overvoltage (hiccup mode) 115-140%	3.3 V _{dc}	V _{o,limit}	3.79	3.96	4.6	V _{dc}
	5.0 V _{dc}	V _{o,limit}	5.75	6.0	7.0	V _{dc}
	12 V _{dc}	V _{o,limit}	13.8	14.4	16.8	V _{dc}
	15 V _{dc}	V _{o,limit}	17.2	18.0	21.0	V _{dc}



CQB100W Series

Application Note V12 February 2012

	24 V _{dc}	V _{o,limit}	27.6	28.8	33.6	V _{dc}
Over Temperature Shutdown (case)	All	T _{CASE,ref}	—	110	—	°C
Over Temperature Restart Hysteresis	All	T _{CASE,hys}	—	10	—	°C
Output Capacitance (External)	3.3~5V _{dc}	C _O	—	—	1,0000	μF
	12~24V _{dc}		—	—	2,200	
Note1: Measured with 10uF Tantalum and 1uF ceramic capacitors at the converter output pins(Over all operating input voltage, resistive load, and temperature conditions until end of life).						

Dynamic Specifications

Parameter	Device	Symbol	Min	Typ	Max	Unit
Output Voltage during Load Current Transient (Note1)						
Peak Deviation	3.3 V _{dc}	V _{pk}			7	%V _o
	Others				5	
Settling Time (<1% normal output)	All	t _s		200	500	μs
Turn-On Transient						
Turn-On Delay (Note2)	All	Td1		20	75	ms
Turn-On Delay (Note3)	All	Td2		110	250	ms
Output Rise time (Note4)	All	Tr		10	50	ms
Notes: Note1: Load change from 50% to 75% to 50% of I _{o,max} ; ΔI _o /Δt=0.1A/μs; V _{IN} =V _{IN,nom} ; T _A =25°C ; 330μF Aluminum external capacitance and 1uF ceramic capacitor. Note2: Power applied first, then enable (time from enable applied until V _O =10% of V _{o,set}); Note3: Enable first, then power applied (time from input V _{IN} =V _{IN,min} until V _O =10% of V _{o,set}); Note4: Time for V _o to rise from 10% of V _{o, set} to 90% of V _{o,set} ;						

4.3 Isolation Specifications

Parameter	Device	Symbol	Min	Typ	Max	Unit
Isolation Capacitance	All	Ciso	—	1000	—	pF
Isolation Resistance	All	Riso	10	—	—	MΩ

4.4 Feature Specifications

Parameter	Device	Symbol	Min	Typ	Max	Units
Negative Remote Control (ON/OFF)						
Logic high-Unit off(Typ=Open Collector)	All		3.5		75.0	V _{dc}
Logic low-Unit On	All		-0.1		0.8	V _{dc}
Sink current	All				1	mA
Source current	All				1	mA
Positive Remote Control (ON/OFF)						
Logic high-Unit off	All		-0.1		0.8	V _{dc}
Logic low-Unit On(Typ=Open Collector)	All		3.5		75.0	V _{dc}
Sink current	All				1	mA
Source current	All				1	mA
Switching Frequency	24SXX	f _{sw}		220		kHz
	48SXX			250		
Mean Time Between Failure (Note1)	All	MTBF		600,000		Hours
Weight	All			66		g
Note1: Calculated according to MIL-HDBK-217F, GB 25°C Full Load						



CQB100W Series

Application Note V12 February 2012

5. Main Features and Functions

5.1 Operating Temperature Range

The CQB100W series converters can be operated within a wide case temperature range of -40°C to 100°C. Consideration must be given to the derating curves when ascertaining maximum power that can be drawn from the converter. The maximum power drawn from Quarter brick models is influenced by usual factors, such as:

- Input voltage range
- Output load current
- Forced air or natural convection

5.2 Output Voltage Adjustment

Section 6.8 describes in detail how to trim the output voltage with respect to its set point. The output voltage on all models is adjustable within the range of +10% to -10%.

5.3 Over Current Protection

The converter is protected against over current or short circuit conditions. At the instance of current-limit inception, the module enters a hiccup mode of operation, whereby it shuts down and automatically attempts to restart. While the fault condition exists, the module will remain in this hiccup mode, and can remain in this mode until the fault is cleared. The unit operates normally once the output current is reduced back into its specified range.

5.4 Output Overvoltage Protection

The converter is protected against output over voltage conditions. When the output voltage is higher than the specified range, the module enters a hiccup mode of operation. The operation is identical with over current protection.

5.6 Remote ON/OFF

The ON/OFF input Pin permits the user to turn the power module on or off via a system signal. Two remote on/off options are available. Positive logic turns the module on during a logic high voltage on the ON/OFF pin, and off during a logic low. Negative logic remote On/Off, turns the module off during a logic high and on during a logic low. The ON/OFF pin is internally pulled up through a resistor. A properly debounced mechanical switch, open collector transistor, or FET can be used to drive the input of the ON/OFF pin.

If not using the remote on/off feature:

For positive logic, leave the ON/OFF pin open.

For negative logic, short the ON/OFF pin to VIN(-).

5.7 UVLO (Undervoltage Lock Out)

Input undervoltage lockout is standard with this converter. At input voltages below the input undervoltage lockout limit, the module operation is disabled.

5.8 Over Temperature Protection

These modules have an over temperature protection circuit to safeguard against thermal damage. When the case temperature rises above over temperature shutdown threshold, the converter will shut down to protect itself from overheating. The module will automatically restarts after it cools down.

6. Applications

6.1 Recommended Layout, PCB Footprint and Soldering Information

The system designer or end user must ensure that metal and other components in the vicinity of the converter meet the spacing requirements for which the system is approved. Low resistance and inductance PCB layout traces are the norm and should be used where possible. Due consideration must also be given to proper low impedance tracks between power module, input and output grounds. The recommended soldering profile and PCB layout are shown below.

Lead Free Wave Soldering Profile

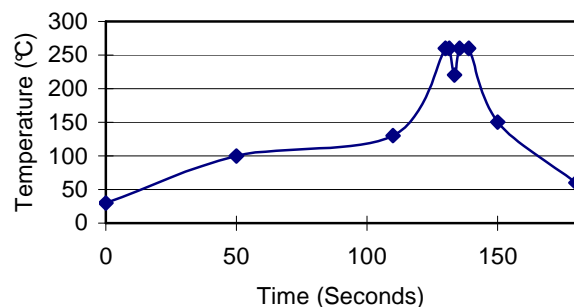

Note :

1. Soldering Materials : Sn/Cu/Ni
2. Ramp up rate during preheat: 1.4 °C/Sec (From 50°C to 100°C)
3. Soaking temperature: 0.5 °C/Sec (From 100°C to 130°C), 60±20 seconds
4. Peak temperature: 260°C, above 250°C 3~6 Seconds
5. Ramp up rate during cooling: -10.0 °C/Sec (From 260°C to 150°C)



CQB100W Series

Application Note V12 February 2012

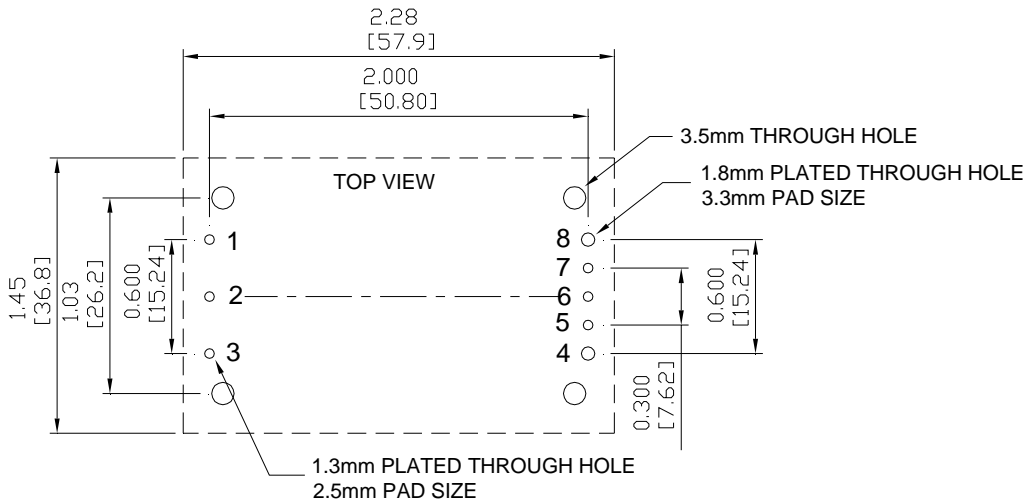

6.2 Convection Requirements for Cooling

To predict the approximate cooling needed for the Quarter brick module, refer to the power derating curves in section 6.4. These derating curves are approximations of the ambient temperatures and airflows required to keep the power module temperature below its maximum rating. Once the module is assembled in the actual system, the module's temperature should be monitored to ensure it does not exceed 100°C as measured at the center of the top of the case (thus verifying proper cooling).

6.3 Thermal Considerations

The power module operates in a variety of thermal environments; however, sufficient cooling should be provided to help ensure reliable operation of the unit. Heat is removed by conduction, convection, and radiation to the surrounding environment. The power output of the module should not be allowed to exceed rated power ($V_{o_set} \times I_{o_max}$).

The power modules have through-threaded, M3 x0.5 mounting holes, which enable heat sinks or cold plates to be attached to the module. Thermal de-rating with heat sinks is expressed by using the overall thermal resistance of the module (R_{ca}).

6.4 Power Derating

The operating case temperature range of CQB100W series is -40°C to +100°C. When operating the CQB100W series, proper de-rating or cooling is needed. The maximum case temperature under any operating condition should not exceed 100°C.

Forced Convection Power De-rating without Heat Sink

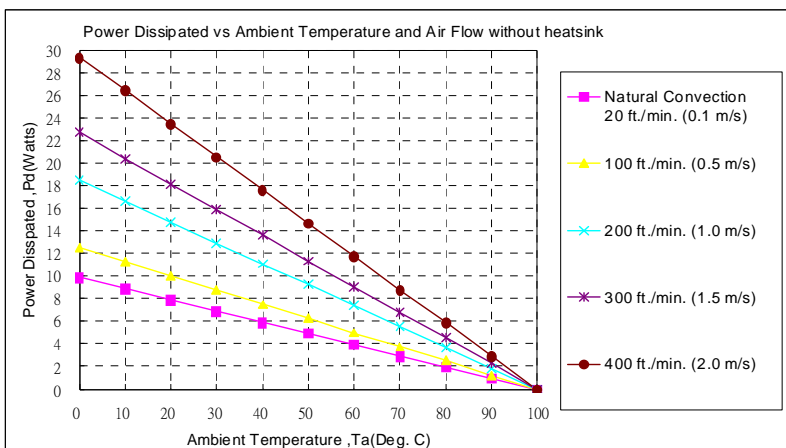

AIR FLOW RATE	TYPICAL R_{ca}
Natural Convection 20ft./min. (0.1m/s)	10.1 °C/W
100 ft./min. (0.5m/s)	8.0 °C/W
200 ft./min. (1.0m/s)	5.4 °C/W
300 ft./min. (1.5m/s)	4.4 °C/W
400 ft./min. (2.0m/s)	3.4 °C/W

Example (without heatsink):

What is the minimum airflow necessary for a CQB100W-48S05 operating at nominal line voltage,



CQB100W Series

Application Note V12 February 2012

an output current of 20A, and a maximum ambient temperature of 40°C ?

Solution:

Given: $V_{in}=48V_{dc}$, $V_o=5V_{dc}$, $I_o=20A$

Determine Power dissipation (P_d):

$$P_d = P_i - P_o = P_o(1-\eta)/\eta$$

$$P_d = 5.0 \times 20 \times (1-0.88)/0.88 = 13.64 \text{ Watts}$$

Determine airflow:

Given: $P_d=13.64W$ and $T_a=40^\circ C$

Check above Power de-rating curve:

$$\text{Airflow} \leq 400 \text{ ft./min.}$$

Verifying: The maximum temperature rise $\Delta T = P_d \times R_{ca} = 13.64 \times 3.4 = 46.4^\circ C$

The maximum case temperature $T_c = T_a + \Delta T = 86.4^\circ C < 100^\circ C$

Where: The R_{ca} is thermal resistance from case to ambience.

The T_a is ambient temperature and the T_c is case temperature

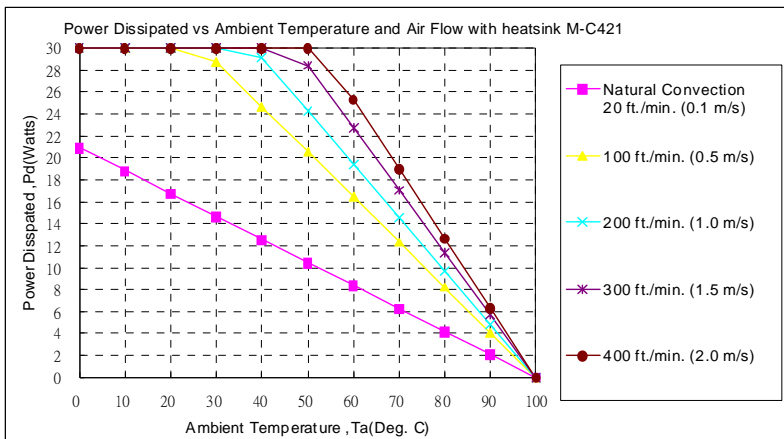

AIR FLOW RATE	TYPICAL R_{ca}
Natural Convection 20ft./min. (0.1 m/s)	4.78 °C/W
100 ft./min. (0.5m/s)	2.44 °C/W
200 ft./min. (1.0m/s)	2.06 °C/W
300 ft./min. (1.5m/s)	1.76 °C/W
400 ft./min. (2.0m/s)	1.58 °C/W

Example (with heatsink M-C421):

What is the minimum airflow necessary for a CQB100W-48S05 operating at nominal line voltage, an output current of 20A, and a maximum ambient temperature of 40°C ?

Solution:

Given: $V_{in}=48V_{dc}$, $V_o=5V_{dc}$, $I_o=20A$

Determine Power dissipation (P_d):

$$P_d = P_i - P_o = P_o(1-\eta)/\eta$$

$$P_d = 5.0 \times 20 \times (1-0.88)/0.88 = 13.64 \text{ Watts}$$

Determine airflow:

Given: $P_d=13.64W$ and $T_a=40^\circ C$

Check above Power de-rating curve:

$$\text{Airflow} \leq 100 \text{ ft./min.}$$

Verifying: The maximum temperature rise $\Delta T = P_d \times R_{ca} = 13.64 \times 2.44 = 33.28^\circ C$

The maximum case temperature $T_c = T_a + \Delta T = 73.28^\circ C < 100^\circ C$

Where: The R_{ca} is thermal resistance from case to ambience.

The T_a is ambient temperature and the T_c is case temperature.



CQB100W Series

Application Note V12 February 2012

6.5 Quarter Brick Heat Sinks:

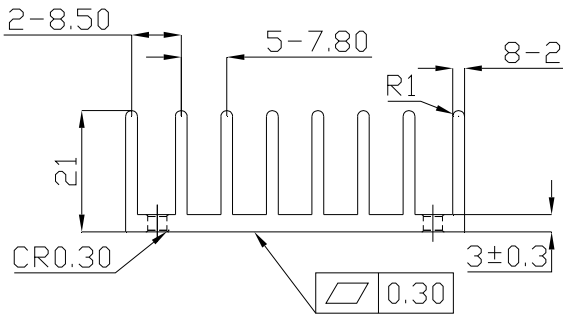
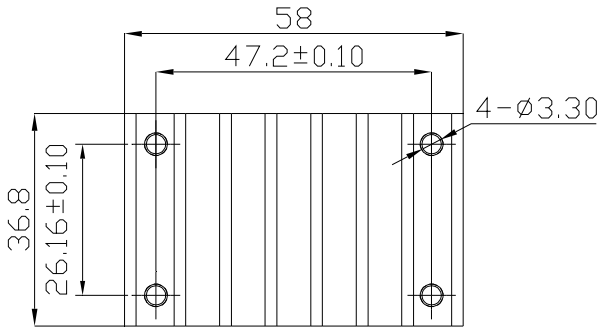

M-C421 (G6620510201)
Transverse Heat Sink

All Dimensions in mm

- Rca: 4.78°C/W (typ.), At natural convection
- 2.44°C/W (typ.), At 100LFM
- 2.06°C/W (typ.), At 200LFM
- 1.76°C/W (typ.), At 300LFM
- 1.58°C/W (typ.), At 400LFM

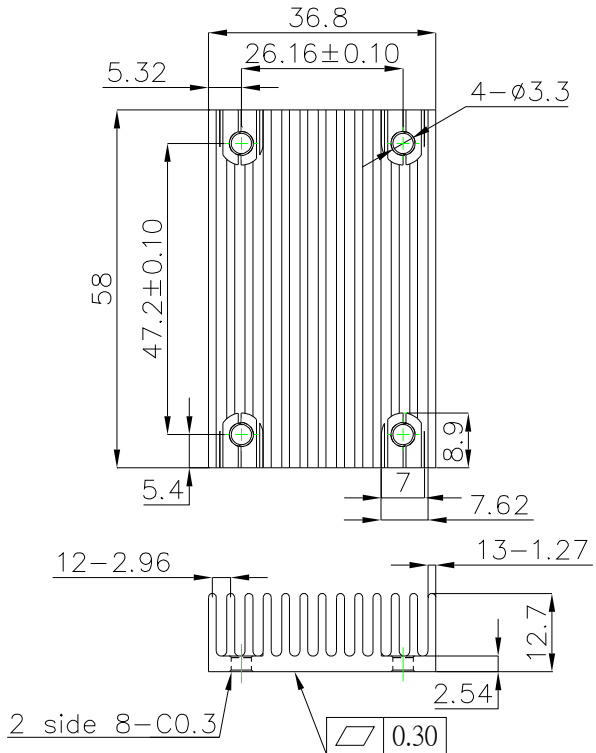

M-C488 (G6620570202)
Longitudinal Heat Sink

- Rca: 5.61°C/W (typ.), At natural convection
- 4.01°C/W (typ.), At 100LFM
- 3.39°C/W (typ.), At 200LFM
- 2.86°C/W (typ.), At 300LFM
- 2.49°C/W (typ.), At 400LFM

THERMAL PAD: SZ 35.8*56.9*0.25 mm (G6135041041)

SCREW: SMP+SW M3*8L (G75A1300322)



CQB100W Series

Application Note V12 February 2012

6.6 Efficiency VS. Load

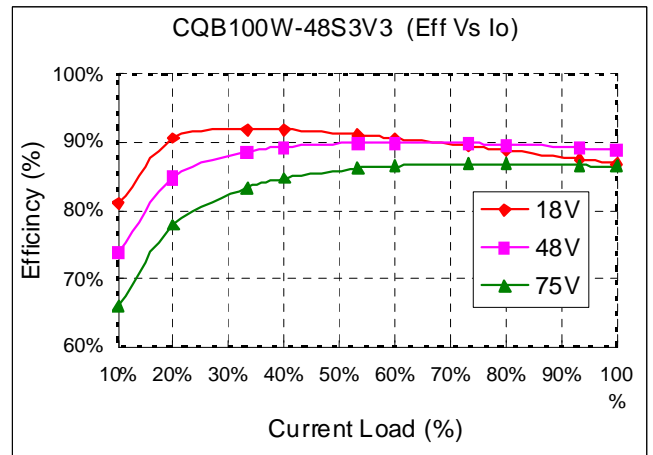
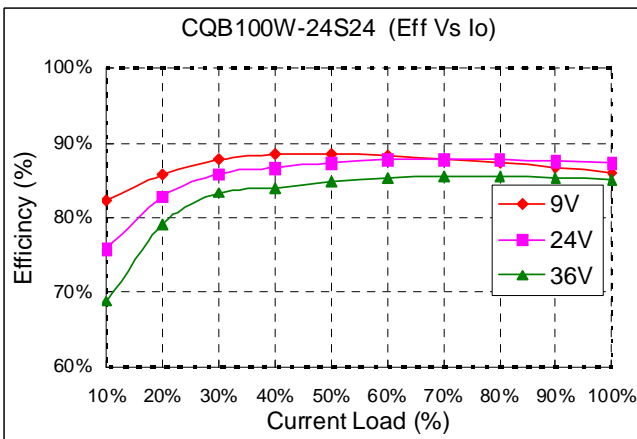
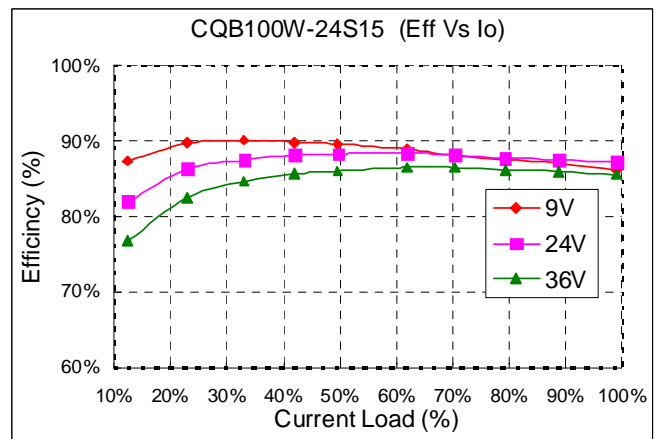
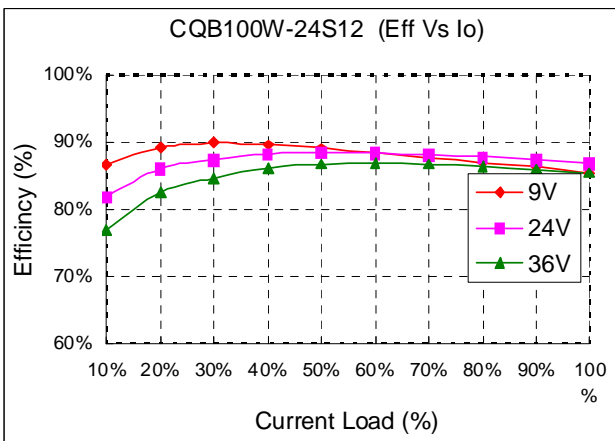
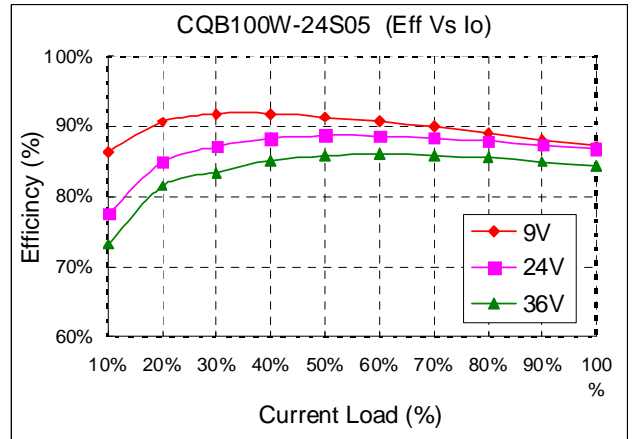
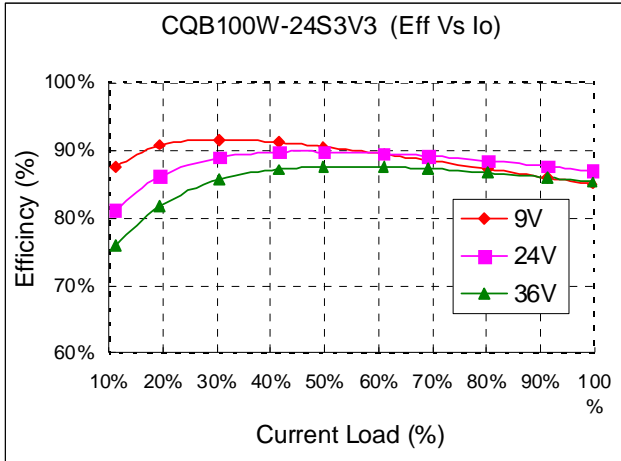



CQB100W Series

Application Note V12 February 2012

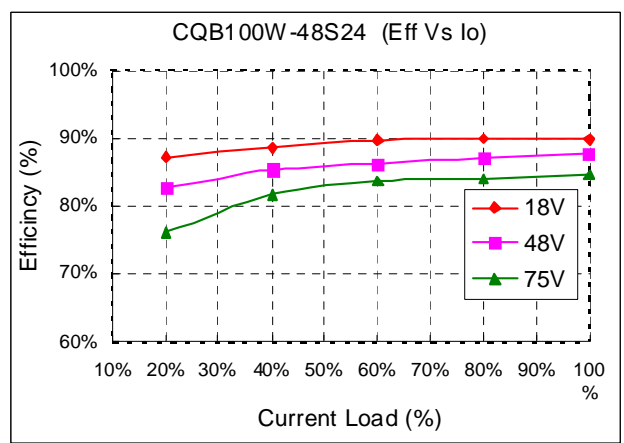
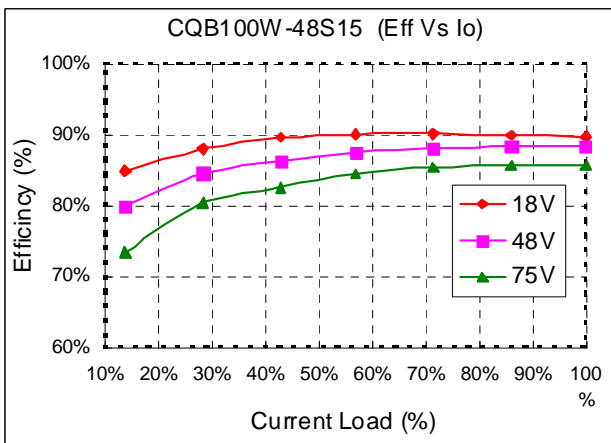
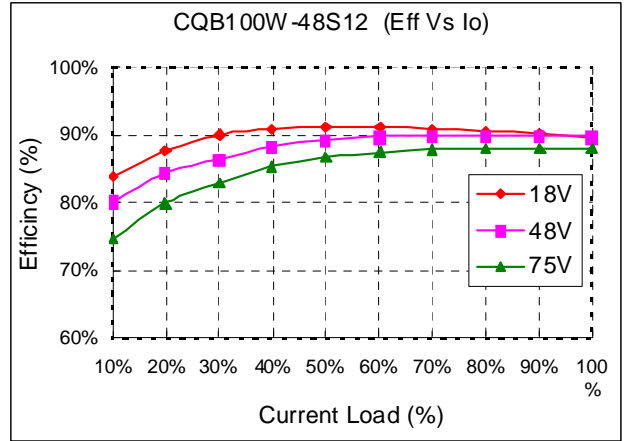
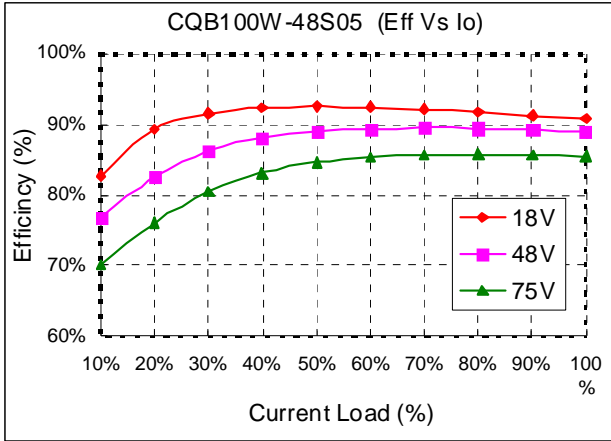



CQB100W Series

Application Note V12 February 2012

6.7 Test Set-Up

The basic test set-up to measure parameters such as efficiency and load regulation is shown below. When testing the modules under any transient conditions please ensure that the transient response of the source is sufficient to power the equipment under test. We can calculate:

- Efficiency
- Load regulation and line regulation.

The value of efficiency is defined as:

$$\eta = \frac{V_o \times I_o}{V_{in} \times I_{in}} \times 100\%$$

Where:

V_o is output voltage,
 I_o is output current,
 V_{in} is input voltage,
 I_{in} is input current.

The value of load regulation is defined as:

$$Load.reg = \frac{V_{FL} - V_{NL}}{V_{NL}} \times 100\%$$

Where:

V_{FL} is the output voltage at full load
 V_{NL} is the output voltage at no load

The value of line regulation is defined as:

$$Line.reg = \frac{V_{HL} - V_{LL}}{V_{LL}} \times 100\%$$

Where: V_{HL} is the output voltage of maximum input voltage at full load. V_{LL} is the output voltage of minimum input voltage at full load.

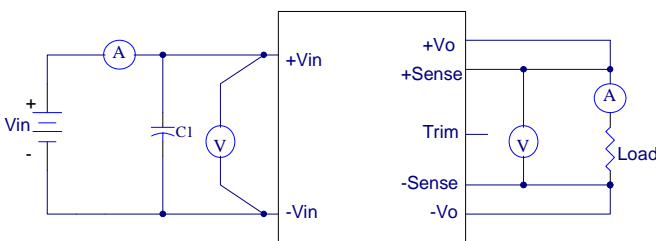

CQB100W Series Test Setup

6.8 Output Voltage Adjustment

The Trim input permits the user to adjust the output voltage up or down 10%. This is accomplished by connecting an external resistor between the Trim pin and either the VO(+) pin or the VO(-) pin (COM pin), see Figure

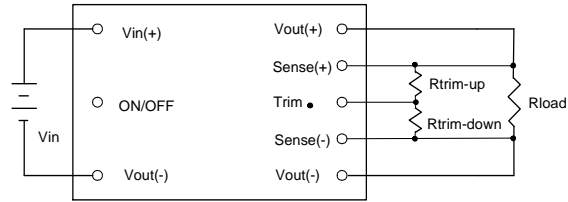

Output voltage trim circuit configuration

The Trim pin should be left open if trimming is not being used. Connecting an external resistor ($R_{trim-down}$) between the Trim pin and the $V_{out(-)}$ (or $Sense(-)$) pin decreases the output voltage. The following equation determines the required external resistor value to obtain a down percentage output voltage change of $\Delta\%$

$$R_{trim-down} = \left[\frac{511}{\Delta\%} - 10.22 \right] k\Omega$$

Where

$$\Delta\% = \left(\frac{V_{o,set} - V_{desired}}{V_{o,set}} \right) \times 100$$

For example, to trim-down the output voltage of 12V module (CQB100W-48S12) by 5% to 11.4V, $R_{trim-down}$ is calculated as follow:

$\Delta\% = 5$

$$R_{trim-down} = \left(\frac{511}{5} - 10.22 \right) k\Omega$$

$$R_{trim-down} = 91.98 k\Omega$$

Connecting an external resistor ($R_{trim-up}$) between the Trim pin and the $V_{out(+)}$ (or $Sense(+)$) pin increases the output voltage. The following equations determine the required external resistor value to obtain a up percentage output voltage change of $\Delta\%$.

$$R_{trim-up} = \left[\frac{5.11 V_{out} (100 + \Delta\%)}{1.225 \times \Delta\%} - \frac{511}{\Delta\%} - 10.22 \right] k\Omega$$

Where

$$V_{out} = V_{o,set}, \Delta\% = \left(\frac{V_{desired} - V_{o,set}}{V_{o,set}} \right) \times 100$$

For example, to trim-up the output voltage of 12V module (CQB100W-48S12) by 5% to 12.6V, $R_{trim-up}$ is calculated as follow:

$\Delta\% = 5$

$$R_{trim-up} = \left(\frac{5.1 \times 12 \times (100 + 5)}{1.225 \times 5} - \frac{511}{5} - 10.22 \right) k\Omega$$

$$R_{trim-up} = 936.74 k\Omega$$



CQB100W Series

Application Note V12 February 2012

6.9 Output Remote Sensing

The CQB100W SERIES converter has the capability to remotely sense both lines of its output. This feature moves the effective output voltage regulation point from the output of the unit to the point of connection of the remote sense pins. This feature automatically adjusts the real output voltage of the CQB100W SERIES in order to compensate for voltage drops in distribution and maintain a regulated voltage at the point of load. The remote-sense voltage range is :

$$[(+V_{out}) - (-V_{out})] - [(+Sense) - (-Sense)] \leq 10\% \text{ of } V_{o_nominal}$$

If the remote sense feature is not to be used, the sense pins should be connected locally. The +Sense pin should be connected to the +Vout pin at the module and the -Sense pin should be connected to the -Vout pin at the module.

This is shown in the schematic below.

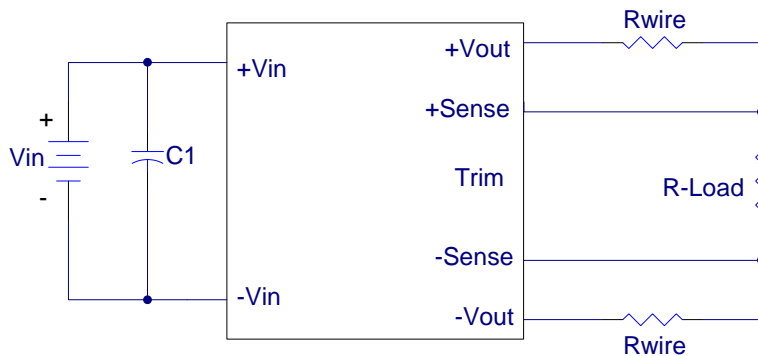

Note: Although the output voltage can be varied (increased or decreased) by both remote sense and trim, the maximum variation for the output voltage is the larger of the two values not the sum of the values. The output power delivered by the module is defined as the voltage at the output terminals multiplied by the output current. Using remote sense and trim can cause the output voltage to increase and consequently increase the power output of the module if output current remains unchanged. Always ensure that the output power of the module remains at or below the maximum rated power. Also be aware that if $V_{o,set}$ is below nominal value, $P_{out,max}$ will also decrease accordingly because $I_{o,max}$ is an absolute limit. Thus, $P_{out,max} = V_{o,set} \times I_{o,max}$ is also an absolute limit.

6.10 Output Ripple and Noise

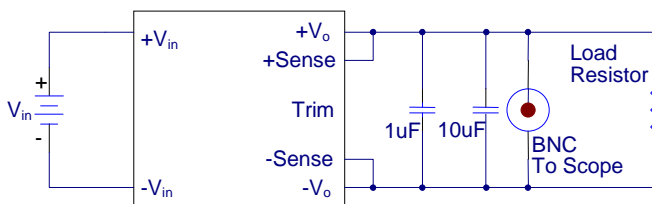

Output ripple and noise is measured with 1.0uF ceramic and 10uF solid tantalum capacitors across the output.

6.11 Output Capacitance

The CQB100W series converters provide unconditional stability with or without external capacitors. For good transient response, low ESR output capacitors should be located close to the point of load. PCB design emphasizes low resistance and inductance tracks in consideration of high current applications. Output capacitors with their associated ESR values have an impact on loop stability and bandwidth. These series converters are designed to work with load capacitance to see technical specifications.



CQB100W Series Application Note V12 February 2012

7. Safety & EMC

7.1 Input Fusing and Safety Considerations

The CQB100W series converters have no internal fuse. In order to achieve maximum safety and system protection, always use an input line fuse. We recommended a 15A time delay fuse for the models. It is recommended that the circuit have a transient voltage suppressor diode (TVS) across the input terminal to protect the unit against surge or spike voltage and input reverse voltage (as shown).

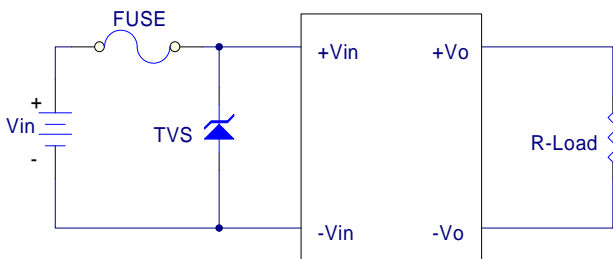

7.2 EMC Considerations

EMI Test standard: EN55022 Class A Conducted Emission
Test Condition: Input Voltage: Nominal, Output Load: Full Load

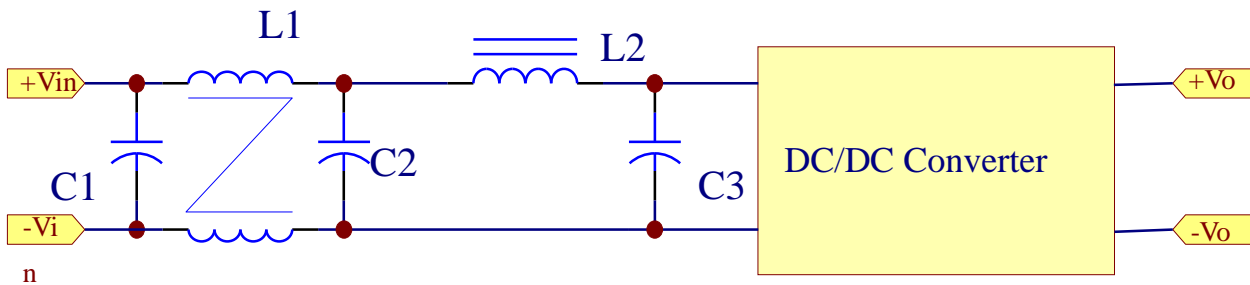

Figure1 Connection circuit for conducted EMI testing

Model No.	C1	C2	C3	L1	L2
CQB100W-48S3V3	150uF/100V	150uF/100V	NC	0.5mH	Short
CQB100W-48S05	150uF/100V	150uF/100V	NC	0.5mH	Short
CQB100W-48S12	150uF/100V	150uF/100V	NC	0.5mH	Short
CQB100W-48S15	150uF/100V	150uF/100V	NC	0.5mH	Short
CQB100W-48S24	150uF/100V	150uF/100V	NC	0.5mH	Short

Note: C1, C2 are aluminum capacitors NIPPON-CHEMICON KY Series



CQB100W Series

Application Note V12 February 2012

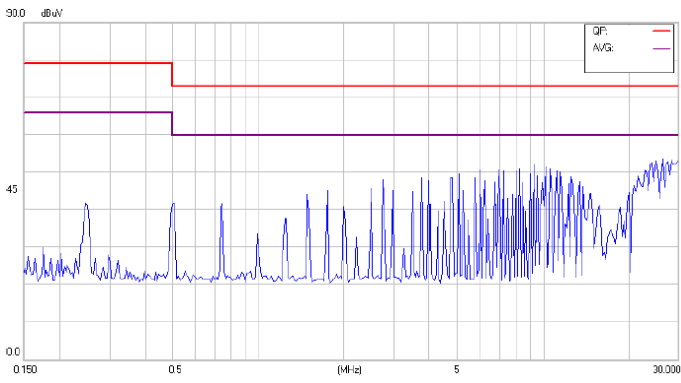

Conducted Class A of CQB100W-48S3V3

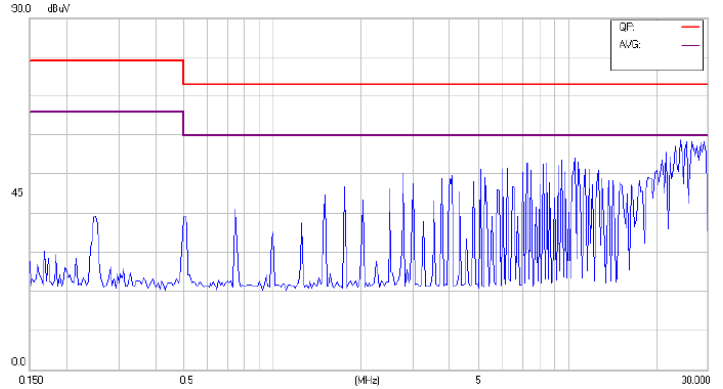

Conducted Class A CQB100W-48S05

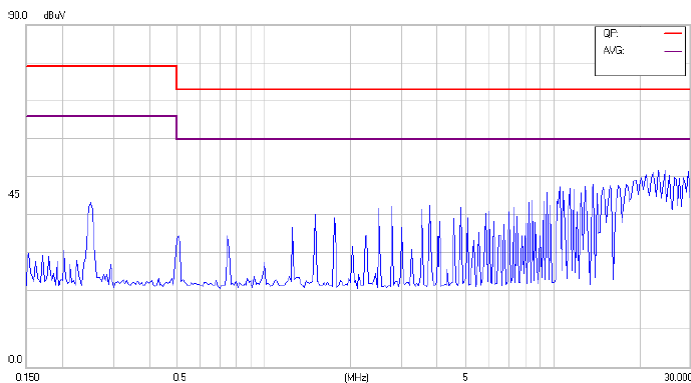

Conducted Class A of CQB100W-48S12

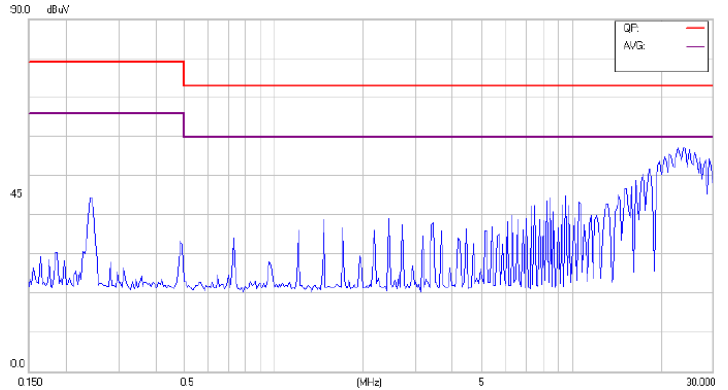

Conducted Class A CQB100W-48S15

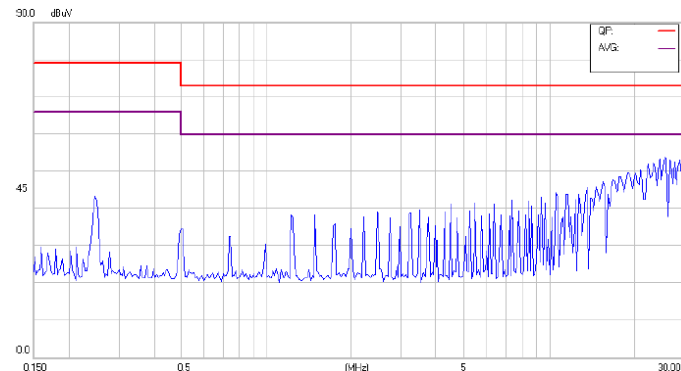

Conducted Class A of CQB100W-48S24



CQB100W Series

Application Note V12 February 2012

8. Part Number

Format: CQB100W – II X OO LY

Parameter	Series	Nominal Input Voltage	Number of Outputs	Output Voltage	Remote ON/OFF Logic	Option
Symbol	CQB100W	II	X	OO	L	Y
Value	CQB100W	24:24Volts 48:48Volts	S: Single	3V3: 3.3 Volts 05: 05 Volts 12: 12 Volts 15: 15 Volts 24: 24 Volts	None: Positive N: Negative	C Clear Mounting Insert

9. Mechanical Specifications

9.1 Mechanical Outline Diagrams

All Dimensions In Inches(mm)

Tolerances Inches: X.XX= ±0.02 , X.XXX= ±0.010

Millimeters: X.X= ±0.5 , X.XX=±0.25

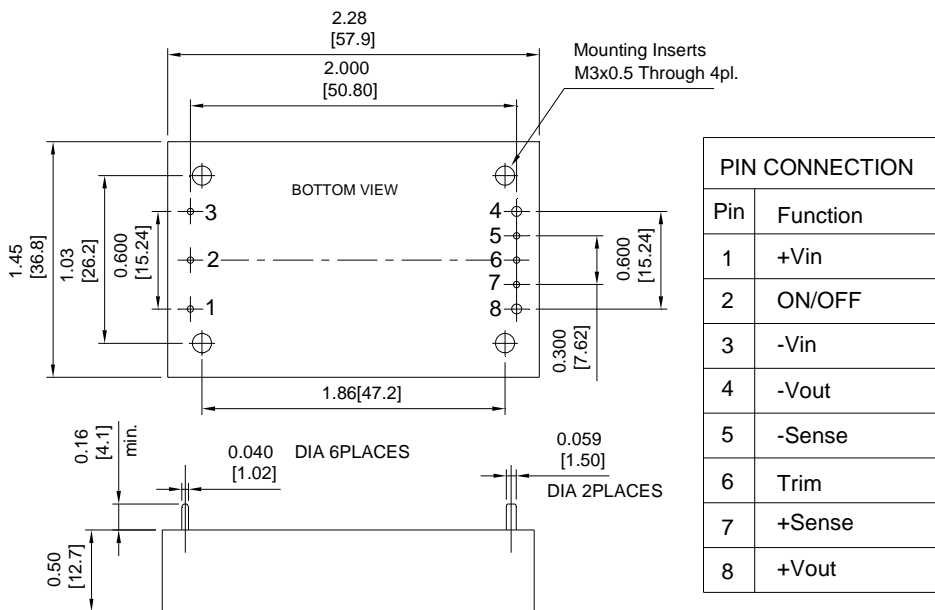

CQB100W Mechanical Outline Diagram

CINCON ELECTRONICS CO., LTD.

Headquarters:

14F, No.306, Sec.4, Hsin Yi Rd.
Taipei, Taiwan
Tel: 886-2-27086210
Fax: 886-2-27029852
E-mail: sales@cincon.com.tw
Web Site: http://www.cincon.com

Factory:

No. 8-1, Fu Kung Rd.
Fu Hsing Industrial Park
Fu Hsing Hsiang,
Chang Hua Hsien, Taiwan
Tel: 886-4-7690261
Fax: 886-4-7698031

Cincon North America:

1655 Mesa Verde Ave. Ste 180
Ventura, CA 93003
Tel: 805-639-3350
Fax: 805-639-4101
E-mail: info@cincon.com