



CHB150W8 Series Application Note V13 February 2020

ISOLATED DC-DC CONVERTER CHB150W8 SERIES APPLICATION NOTE



Approved By:

Department	Approved By	Checked By	Written By
Research and Development Department	Enoch	Danny/Paul	Joyce
		Jacky	
Quality Assurance Department	Ryan	Benny	



CHB150W8 Series Application Note V13 February 2020

Contents

1. Introduction	3
2. DC-DC Converter Features	3
3. Electrical Block Diagram	3
4. Technical Specifications	4
5. Main Features and Functions	8
5.1 Operating Temperature Range	8
5.2 Output Voltage Adjustment	8
5.3 Over Current Protection	8
5.4 Output Over Voltage Protection	8
5.5 Remote On/Off	8
5.6 UVLO (Under Voltage Lock Out)	8
5.7 Over Temperature Protection	8
6. Applications	8
6.1 Recommended Layout, PCB Footprint and Soldering Information	8
6.2 Convection Requirements for Cooling	9
6.3 Thermal Considerations	9
6.4 Power De-rating	10
6.5 Half Brick Heat Sinks:	12
6.6 Efficiency VS. Load	13
6.7 Test Set-Up	14
6.8 Output Voltage Adjustment	14
6.9 Output Ripple and Noise	16
6.10 Output Capacitance	16
7. Safety & EMC	16
7.1 Input Fusing and Safety Considerations	16
7.2 EMC Considerations	16
8. Part Number	18
9. Mechanical Specifications	18
9.1 Mechanical Outline Diagrams	18



CHB150W8 Series

Application Note V13 February 2020

1. Introduction

This specification describes the features and functions of Cincon's CHB150W8 series of isolated DC-DC converters. These are highly efficient, reliable and compact, high power density, single output DC/DC converters. The modules can be used in the field of telecommunications, data communications, wireless communications, servers etc. The CHB150W8 series can deliver up to 12.5A output current and provide a precisely regulated output voltage over a wide range of 9-75VDC. The modules can achieve high efficiency up to 90%. The module offers direct cooling of dissipative components for excellent thermal performance. Standard features include remote on/off (positive or negative), remote sense, output voltage adjustment, over voltage, over current and over temperature protection.

2. DC-DC Converter Features

- 150W Isolated Output
- Efficiency up to 90%
- Fixed Switching Frequency
- Input Under Voltage Protection
- Over Temperature Protection
- Over Voltage/Current Protection
- Remote On/Off
- Industry Standard Half-Brick Package
- Fully Isolated 1500VDC
- UL60950-1 2nd Approval

3. Electrical Block Diagram

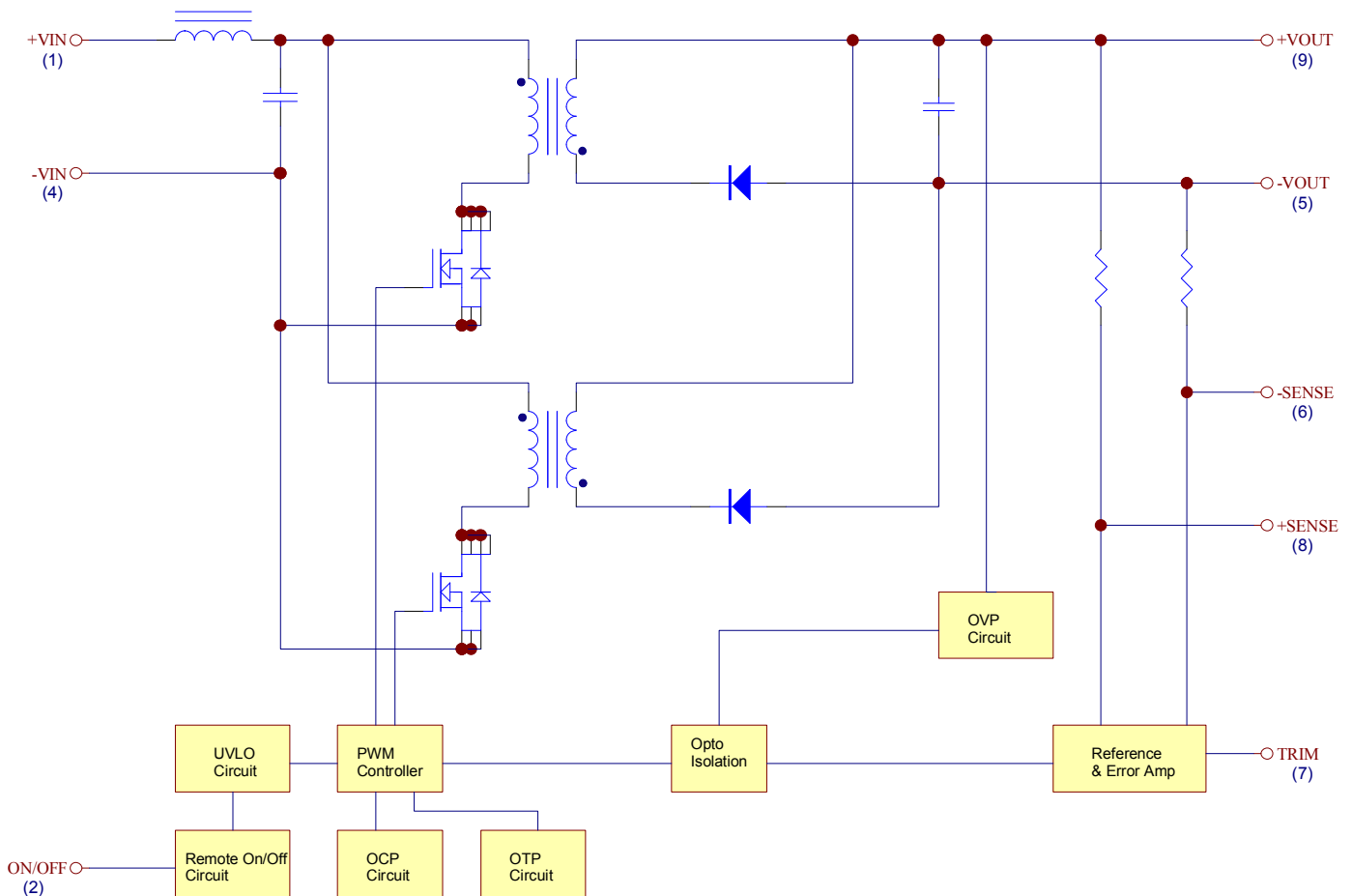

Electrical Block Diagram



CHB150W8 Series

Application Note V13 February 2020

4. Technical Specifications

(All specifications are typical at nominal input, full load at 25°C unless otherwise noted.)

ABSOLUTE MAXIMUM RATINGS						
PARAMETER	NOTES and CONDITIONS	Device	Min.	Typical	Max.	Units
Input Voltage						
Continuous		All	-0.3		75	V _{dc}
Transient	100ms	All			100	V _{dc}
Operating Case Temperature		All	-40		100	°C
Storage Temperature		All	-55		105	°C
Isolation Voltage	1 minute, input/output, input/case, output/case	All	1500			V _{dc}

INPUT CHARACTERISTICS

PARAMETER	NOTES and CONDITIONS	Device	Min.	Typical	Max.	Units
Operating Input Voltage		All	9	36	75	V _{dc}
Input Undervoltage Lockout						
Turn-On Voltage Threshold		All	8.5	9.0	9.5	V _{dc}
Turn-Off Voltage Threshold		All	7.5	8.0	8.5	V _{dc}
Lockout Hysteresis Voltage		All		1		V _{dc}
Maximum Input Current	100% load, V _{in} = 9V	All		20		A
No-Load Input Current	V _{in} = 36V	36S12 36S15 36S24 36S28 36S48		60 60 60 60 60		mA
Inrush Current (I ² t)		All			1	A ² s
Input Reflected-Ripple Current	P-P thru 10uH inductor, 5Hz to 20MHz	All			50	mA
Recommended Input Fuse	Fast acting type	All		30		A
Input Capacitance (External)	<0.7Ω ESR	All		330		uF

OUTPUT CHARACTERISTICS

PARAMETER	NOTES and CONDITIONS	Device	Min.	Typical	Max.	Units
Output Voltage Set Point	V _{in} = Nominal V _{in} , I _o = I _{o_max} , T _C = 25°C	36S12 36S15 36S24 36S28 36S48	11.88 14.85 23.76 27.72 47.52	12 15 24 28 48	12.12 15.15 24.24 28.28 48.48	V _{dc}
Output Voltage Regulation						
Load Regulation	I _o = I _{o_min} to I _{o_max}	All			±0.2	%
Line Regulation	V _{in} = low line to high line	All			±0.2	%
Temperature Coefficient	T _C = -40°C to 100°C	All			±0.03	%/°C



CHB150W8 Series

Application Note V13 February 2020

OUTPUT CHARACTERISTICS

PARAMETER	NOTES and CONDITIONS	Device	Min.	Typical	Max.	Units
Output Voltage Ripple and Noise(5Hz to 20MHz bandwidth)						
Peak-to-Peak	Full load, 10uF tantalum (for 48Vout with 10uF Aluminum) and 1.0uF ceramic capacitors	36S12			120	mV
		36S15			120	
		36S24			280	
		36S28			280	
		36S48			480	
RMS	Full load, 10uF tantalum (for 48Vout with 10uF Aluminum) and 1.0uF ceramic capacitors	36S12			60	mV
		36S15			60	
		36S24			100	
		36S28			100	
		36S48			200	
Operating Output Current Range		36S12	0		12.5	A
		36S15	0		10	
		36S24	0		6.25	
		36S28	0		5.35	
		36S48	0		3.13	
Output Current Limit Inception		All	105	160	200	%
Maximum Output Capacitance	Full load (resistive)	36S12	0		5000	uF
		36S15	0		5000	
		36S24	100		2000	
		36S28	100		1500	
		36S48	100		1000	

DYNAMIC CHARACTERISTICS

PARAMETER	NOTES and CONDITIONS	Device	Min.	Typical	Max.	Units
Output Voltage Transient Response						
Step Change in Output Current	$d_i/d_t=0.1A/us$, Load change from 75% to 100% to 75% of I_o,max $V_{in}=24,36,48V$; output Capacitance 100uF, 10uF solid tantalum and 1.0uF ceramic capacitors	36S12			± 5	%Vo
		36S15			± 5	
		36S24			± 5	
		36S28			± 5	
		36S48			± 5	
Setting Time (within 1% Vout nominal)	$d_i/d_t=0.1A/us$, $V_{in}=24,36,48V$, output Capacitance 100uF	36S12			500	us
		36S15			500	
		36S24			500	
		36S28			500	
		36S48			500	



CHB150W8 Series

Application Note V13 February 2020

DYNAMIC CHARACTERISTICS

PARAMETER	NOTES and CONDITIONS	Device	Min.	Typical	Max.	Units
Turn-On Delay and Rise Time						
Turn-On Delay Time, From On/Off Control	$V_{on/off}$ to $90\%V_{o_set}$	All		80	100	ms
Turn-On Delay Time, From Input	V_{in_min} to $90\%V_{o_set}$	All		100	150	ms
Output Voltage Rise Time	$10\%V_{o_set}$ to $90\%V_{o_set}$	All		30	50	ms

EFFICIENCY

PARAMETER	NOTES and CONDITIONS	Device	Min.	Typical	Max.	Units
100% Load	$V_{in}=24V$	36S12		89.5		%
		36S15		90		
		36S24		89.5		
		36S28		90		
		36S48		90.5		
	$V_{in}=36V$	36S12		89.5		%
		36S15		90		
		36S24		89.5		
		36S28		90		
		36S48		90		
	$V_{in}=48V$	36S12		89.5		%
		36S15		90		
		36S24		89		
		36S28		89.5		
		36S48		89.5		

ISOLATION CHARACTERISTICS

PARAMETER	NOTES and CONDITIONS	Device	Min.	Typical	Max.	Units
Input to Output	1 minute, input/output, input/case, output/case	All			1500	V_{dc}
Isolation Resistance		All	10			M Ω
Isolation Capacitance		36S12		3500		pF
		36S15		3500		
		36S24		2500		
		36S28		2500		
		36S48		2500		

FEATURE CHARACTERISTICS

PARAMETER	NOTES and CONDITIONS	Device	Min.	Typical	Max.	Units
Switching Frequency		All		200		KHz
On/Off Control, Positive Remote On/Off logic						
Logic Low (Module Off)		All	0		1.2	V_{dc}
Logic High (Module On)		All	3.5 or Open Circuit		75	V_{dc}



CHB150W8 Series Application Note V13 February 2020

PARAMETER	NOTES and CONDITIONS	Device	Min.	Typical	Max.	Units
On/Off Control, Negative Remote On/Off logic						
Logic High (Module Off)		All	3.5 or Open Circuit		75	V _{dc}
Logic High (Module On)		All	0		1.2	V _{dc}
On/Off Current (for both remote on/off logic)	I _{on/off} at V _{on/off} =0.0V	All			1	mA
Leakage Current (for both remote on/off logic)	Logic High, V _{on/off} =15V	All			1	mA
Off Converter Input Current	Shutdown input idle current	All		12	18	mA
Output Voltage Trim Range	V _{in} =high line-low line, P _{out} =max rated power, I _{out} =max rated current	Others	-10		+10	%
	V _{in} =9-13V, I _{out} =max rated current	36S28	-10		0	
	V _{in} =13-75V, P _{out} =max rated power, I _{out} =max rated current	36S28	-10		+10	
Output Over Voltage Protection		All	115	125	140	%
Over-Temperature Shutdown		All		110		°C
GENERAL SPECIFICATIONS						
PARAMETER	NOTES and CONDITIONS	Device	Min.	Typical	Max.	Units
MTBF	I _o =100% of I _{o,max} : T _a =25°C per MIL-HDBK-217F, GB	All		800		K hours
Weight		All		109		grams



CHB150W8 Series

Application Note V13 February 2020

5. Main Features and Functions

5.1 Operating Temperature Range

The CHB150W8 series converters can be operated within a wide case temperature range of -40°C to 100°C . Consideration must be given to the de-rating curves when ascertaining maximum power that can be drawn from the converter. The maximum power drawn from half brick models is influenced by usual factors, such as:

- Input voltage range
- Output load current
- Forced air or natural convection

5.2 Output Voltage Adjustment

Section 6.8 describes in detail how to trim the output voltage with respect to its set point. The output voltage on 12V&15V&24V&48V models is adjustable within the range of +10% to -10%. For 28V model, see input& output trim curves.

5.3 Over Current Protection

The converter is protected against over current or short circuit conditions. At the instance of current-limit inception, the module enters a hiccup mode of operation, whereby it shuts down and automatically attempts to restart. While the fault condition exists, the module will remain in this hiccup mode, and can remain in this mode until the fault is cleared. The unit operates normally once the output current is reduced back into its specified range.

5.4 Output Over Voltage Protection

The converter is protected against output over voltage conditions. When the output voltage is higher than the specified range, the module enters a hiccup mode of operation. The operation is identical with over current protection.

5.5 Remote On/Off

The On/Off input pin permits the user to turn the power module on or off via a system signal. Two remote on/off options are available. Positive logic turns the module on during a logic high voltage on the on/off pin, and off during a logic low. Negative logic remote on/off turns the module off during a logic high and on during a logic low. The on/off pin is internally pulled up through a resistor. A properly de-bounced mechanical switch, open collector transistor, or FET can be used to drive the input of the On/Off pin. If not using the remote on/off feature: For positive logic, leave the On/Off pin open. For negative logic, short the on/off pin to Vin(-).

5.6 UVLO (Under Voltage Lock Out)

Input under voltage lockout is standard with this converter. At input voltages below the input under voltage lockout limit, the module operation is disabled.

5.7 Over Temperature Protection

These modules have an over temperature protection circuit to safeguard against thermal damage. When the case temperature rises above over temperature shutdown threshold, the converter will shut down to protect it from overheating. The module will automatically restart after it cools down.

6. Applications

6.1 Recommended Layout, PCB Footprint and Soldering Information

The system designer or end user must ensure that metal and other components in the vicinity of the converter meet the spacing requirements for which the system is approved. Low resistance and inductance PCB layout traces are the norm and should be used where possible. Due consideration must also be given to proper low impedance tracks between power module, input and output grounds. The recommended soldering profile and PCB layout are shown below.

Lead Free Wave Soldering Profile

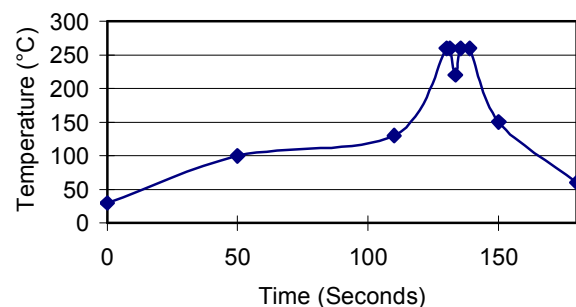

Note :

1. Soldering Materials: Sn/Cu/Ni
2. Ramp up rate during preheat: $1.4^{\circ}\text{C}/\text{Sec}$ (From 50°C to 100°C)
3. Soaking temperature: $0.5^{\circ}\text{C}/\text{Sec}$ (From 100°C to 130°C), 60 ± 20 seconds
4. Peak temperature: 260°C , above 250°C 3~6 Seconds
5. Ramp up rate during cooling: $-10.0^{\circ}\text{C}/\text{Sec}$ (From 260°C to 150°C)



CHB150W8 Series

Application Note V13 February 2020

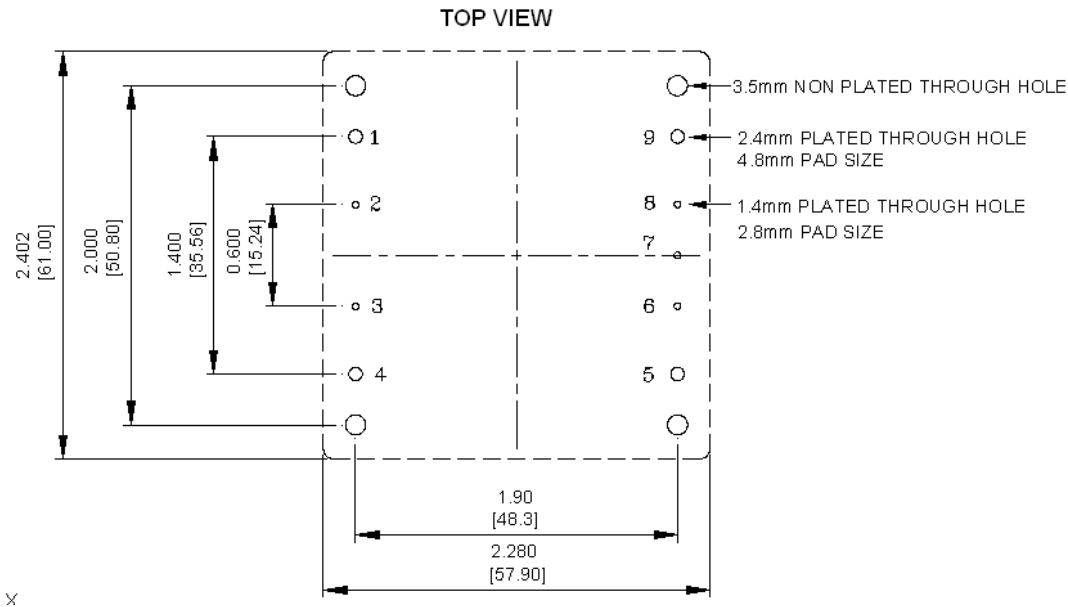

6.2 Convection Requirements for Cooling

To predict the approximate cooling needed for the half brick module, refer to the power de-rating curves in section 6.4. These de-rating curves are approximations of the ambient temperatures and airflows required to keep the power module temperature below its maximum rating. Once the module is assembled in the actual system, the module's temperature should be monitored to ensure it does not exceed 100°C as being measured at the center of the top of the case (thus verifying proper cooling).

6.3 Thermal Considerations

The power module operates in a variety of thermal environments; however, sufficient cooling should be provided to help ensure reliable operation of the unit. Heat is removed by conduction, convection, and radiation to the surrounding environment. The test data is presented in section 6.4. The power output of the module should not be allowed to exceed rated power ($V_{o_set} \times I_{o_max}$).



CHB150W8 Series

Application Note V13 February 2020

6.4 Power De-rating

The operating case temperature range of CHB150W8 series is -40°C to $+100^{\circ}\text{C}$. When operating the CHB150W8 series, proper de-rating or cooling is needed. The maximum case temperature under any operating condition should not exceed 100°C .

The following curve is the de-rating curve of CHB150W8 series without heat sink.

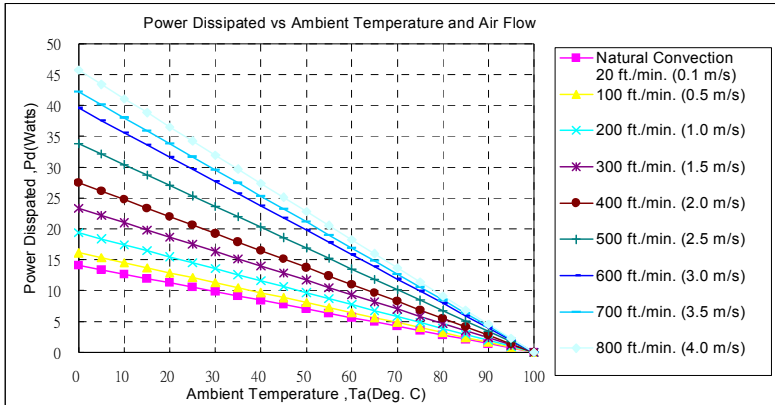

AIR FLOW RATE	TYPICAL R _{ca}
Natural Convection 20ft./min. (0.1m/s)	7.12 °C/W
100 ft./min. (0.5m/s)	6.21 °C/W
200 ft./min. (1.0m/s)	5.17 °C/W
300 ft./min. (1.5m/s)	4.29 °C/W
400 ft./min. (2.0m/s)	3.64 °C/W
500 ft./min. (2.5m/s)	2.96 °C/W
600 ft./min. (2.5m/s)	2.53 °C/W
700 ft./min. (2.5m/s)	2.37 °C/W
800 ft./min. (2.5m/s)	2.19 °C/W

Example (without heatsink):

What is the minimum airflow necessary for a CHB150W8-36S12 operating at nominal line voltage, an output current of 12.5A, and a maximum ambient temperature of 40°C ?

Solution:

Given:

$$V_{in}=36\text{Vdc}, V_o=12\text{Vdc}, I_o=12.5\text{A}$$

Determine Power dissipation (Pd):

$$P_d = P_i - P_o = P_o(1-\eta)/\eta$$

$$P_d = 12\text{V} \times 12.5\text{A} \times (1-0.895)/0.895 = 17.60\text{Watts}$$

Determine airflow:

$$\text{Given: } P_d = 17.60\text{W and } T_a = 40^{\circ}\text{C}$$

Check Power De-rating curve:

$$\text{Minimum airflow} = 500 \text{ ft./min.}$$

Verify:

Maximum temperature rise is

$$\Delta T = P_d \times R_{ca} = 17.60\text{W} \times 2.96 = 52.1^{\circ}\text{C}.$$

Maximum case temperature is

$$T_c = T_a + \Delta T = 92.1^{\circ}\text{C} < 100^{\circ}\text{C}.$$

Where:

The R_{ca} is thermal resistance from case to ambient environment.

T_a is ambient temperature and T_c is case temperature.



CHB150W8 Series

Application Note V13 February 2020

Example with heatsink HBL210 (M-C308):

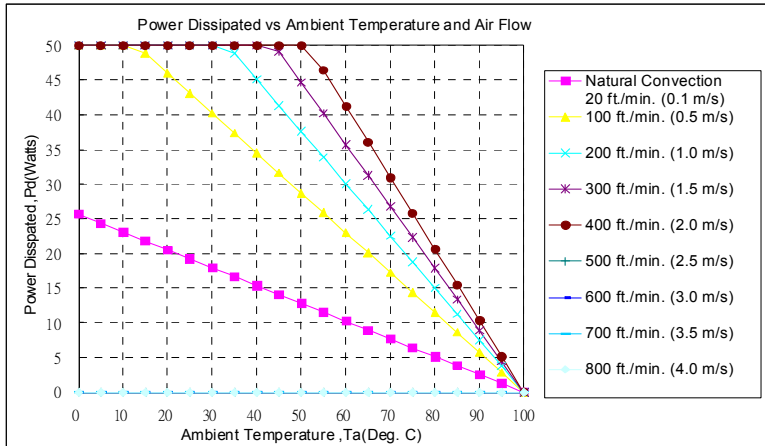

AIR FLOW RATE	TYPICAL R_{ca}
Natural Convection	3.9 °C/W
20ft./min. (0.1m/s)	
100 ft./min. (0.5m/s)	1.74 °C/W
200 ft./min. (1.0m/s)	1.33 °C/W
300 ft./min. (1.5m/s)	1.12 °C/W
400 ft./min. (2.0m/s)	0.97 °C/W

Solution:

Given:

$$V_{in}=36V_{dc}, V_o=12V_{dc}, I_o=12.5A$$

Determine Power dissipation (P_d):

$$P_d = P_i - P_o = P_o(1-\eta)/\eta$$

$$P_d = 12V \times 12.5A \times (1-0.895)/0.895 = 17.60Watts$$

Determine airflow:

$$\text{Given: } P_d = 17.60W \text{ and } T_a = 40^\circ C$$

Check Power De-rating curve:

Minimum airflow= 100 ft./min.

Verify:

Maximum temperature rise is

$$\Delta T = P_d \times R_{ca} = 17.60W \times 1.74 = 30.6^\circ C.$$

Maximum case temperature is

$$T_c = T_a + \Delta T = 70.6^\circ C < 100^\circ C.$$

Where:

The R_{ca} is thermal resistance from case to ambient environment.

T_a is ambient temperature and T_c is case temperature.



CHB150W8 Series

Application Note V13 February 2020

6.5 Half Brick Heat Sinks:

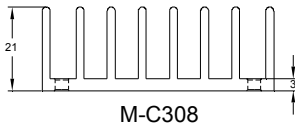
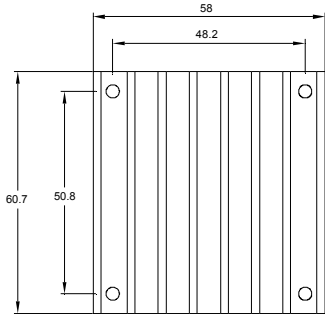

M-C308

HBL210 (M-C308) G6620400201
Longitudinal Heat Sink

Rca:
 3.90°C/W (typ.), natural convection
 1.74°C/W (typ.), at 100LFM
 1.33°C/W (typ.), at 200LFM
 1.12°C/W (typ.), at 300LFM
 0.97°C/W (typ.), at 400LFM

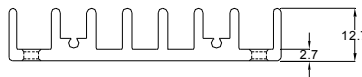
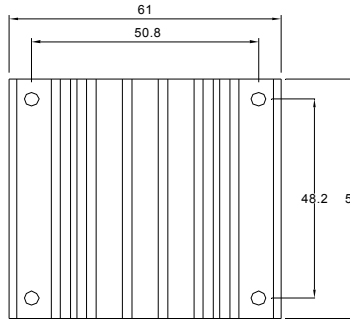

M-C091

HBT127 (M-C091) G6610120402
Transverse Heat Sink

Rca:
 4.70°C/W (typ.), natural convection
 2.89°C/W (typ.), at 100LFM
 2.30°C/W (typ.), at 200LFM
 1.88°C/W (typ.), at 300LFM
 1.59°C/W (typ.), at 400LFM

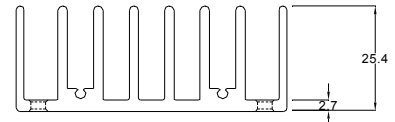
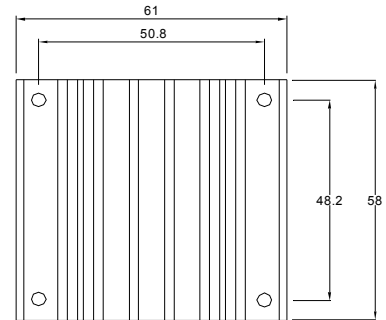

M-C092

HBT254 (M-C092) G6610130402
Transverse Heat Sink

Rca:
 3.00°C/W (typ.), natural convection
 1.44°C/W (typ.), at 100LFM
 1.17°C/W (typ.), at 200LFM
 1.04°C/W (typ.), at 300LFM
 0.95°C/W (typ.), at 400LFM

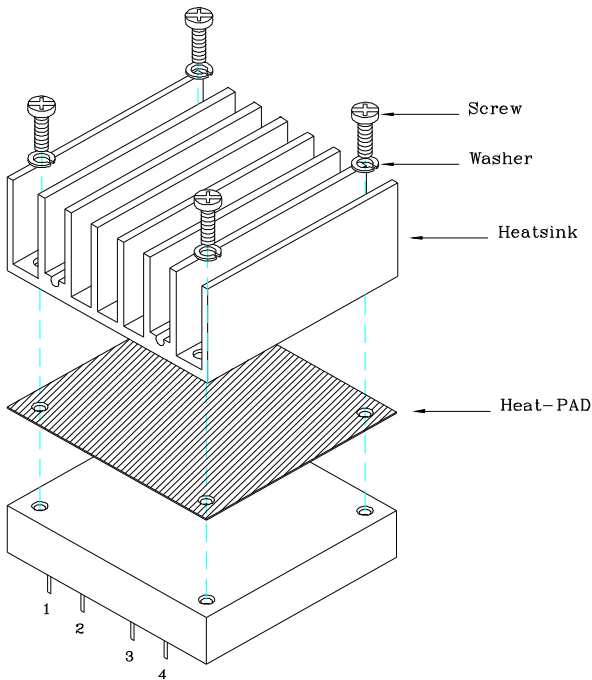

THERMAL PAD PH01: SZ 56.9*60*0.25 mm (G6135041091)
 SCREW & Washer: M3*8L (G75A1300322) & WS3.2N (G75A47A0752)



CHB150W8 Series

Application Note V13 February 2020

6.6 Efficiency VS. Load

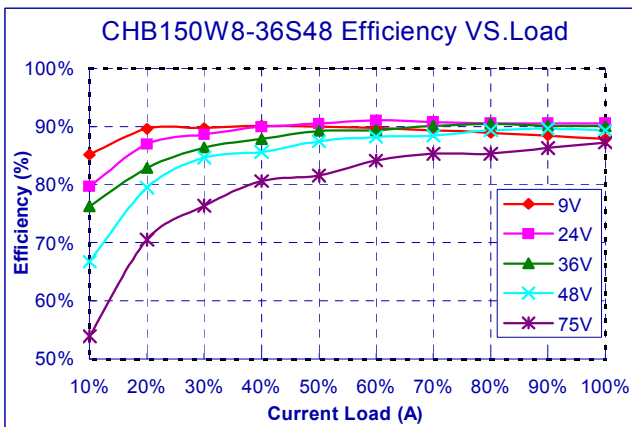
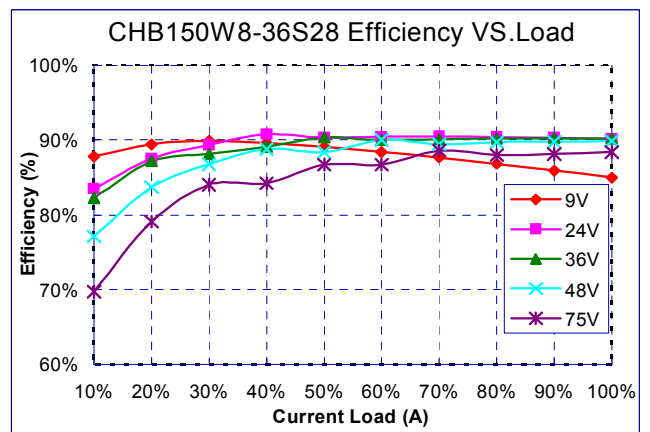
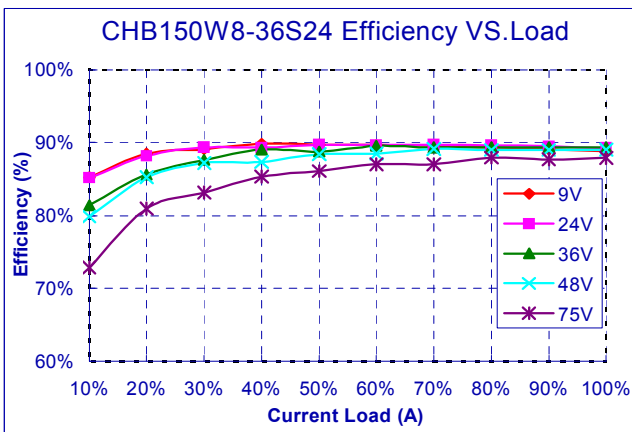
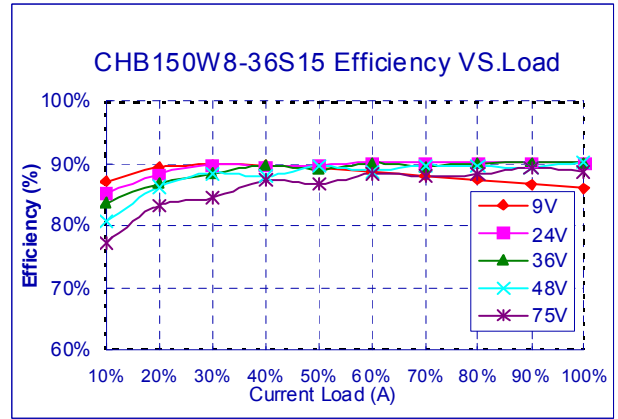
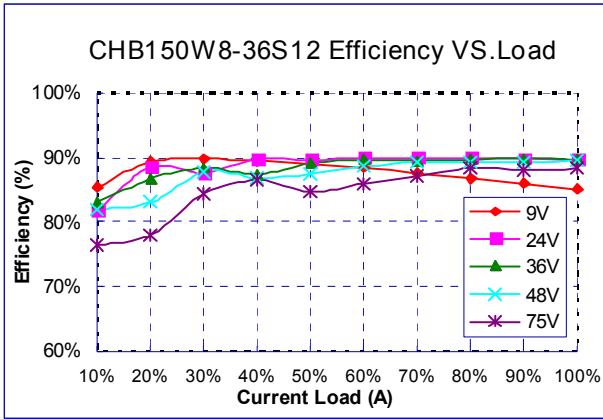



CHB150W8 Series

Application Note V13 February 2020

6.7 Test Set-Up

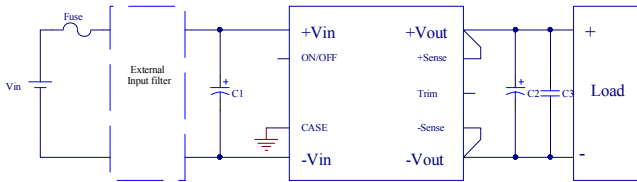

Typical electrical connection (Positive logic)

For typical electrical connection, please refer to the connection above.

1. Put input capacitor, C1 more than 330uF for 36Vin models If the ambient temperature is less than -20 °C, use twice of the recommended capacitor above. If the impedance of input line is high, input capacitor must be more than above.
2. Put output capacitor, C2 and C3, according to minimum and maximum capacitor recommendation on page 7. If the ambient temperature is less than -20 °C, use at least 3 pieces of the recommended minimum capacitors.
3. Use external fuse for each unit.

The basic test set-up to measure parameters such as efficiency and load regulation is shown below. When testing the modules under any transient conditions please ensure that the transient response of the source is sufficient to power the equipment under test. We can calculate:

- Efficiency
- Load regulation and line regulation.

The value of efficiency is defined as:

$$\eta = \frac{V_o \times I_o}{V_{in} \times I_{in}} \times 100\%$$

Where:

- V_o is output voltage
- I_o is output current
- V_{in} is input voltage
- I_{in} is input current.

The value of load regulation is defined as:

$$Load.reg = \frac{V_{FL} - V_{NL}}{V_{NL}} \times 100\%$$

Where:

- V_{FL} is the output voltage at full load
- V_{NL} is the output voltage at no load

The value of line regulation is defined as:

$$Line.reg = \frac{V_{HL} - V_{LL}}{V_{LL}} \times 100\%$$

Where: V_{HL} is the output voltage of maximum input voltage at full load. V_{LL} is the output voltage of minimum input voltage at full load.

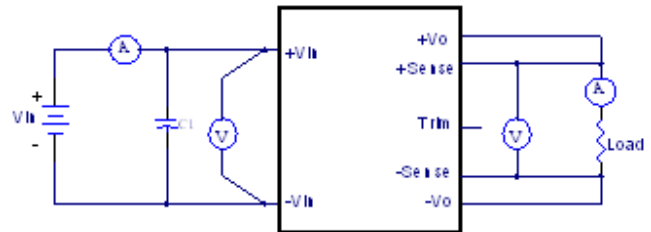

CHB150W8 Series Test Setup

6.8 Output Voltage Adjustment

The Trim input permits the user to adjust the output voltage up or down 10%. This is accomplished by connecting an external resistor between the Trim pin and either the $V_{out}(+)$ pin or the $V_{out}(-)$ pin (COM pin), see Figure

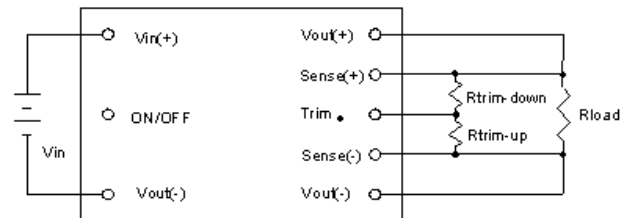

Output voltage trim circuit configuration

The Trim pin should be left open if trimming is not being used. Connecting an external resistor ($R_{trim-down}$) between the Trim pin and the $V_{out}(+)$ (or Sense(+)) pin decreases the output voltage. The following equation determines the required external resistor value to obtain a down percentage output voltage change of $\Delta\%$

$V_{out}=12V, 15V$

$$R_{trim_down} = 20 * \frac{(V_{o,set} - \Delta\% * V_{o,set} - 1.24)}{\Delta\% * V_{o,set}} - 100K\Omega$$

$V_{out}=24V$

$$R_{trim_down} = 20 * \frac{(V_{o,set} - \Delta\% * V_{o,set} - 2.5)}{\Delta\% * V_{o,set}} - 100K\Omega$$

$V_{out}=28V$

$$R_{trim_down} = 23.7 * \frac{(V_{o,set} - \Delta\% * V_{o,set} - 2.5)}{\Delta\% * V_{o,set}} - 150K\Omega$$

$V_{out}=48V$

$$R_{trim_down} = 36 * \frac{(V_{o,set} - \Delta\% * V_{o,set} - 2.5)}{\Delta\% * V_{o,set}} - 200K\Omega$$



CHB150W8 Series

Application Note V13 February 2020

Where

$$V_{out} = V_{o,set}, \Delta\% = \left(\frac{V_{o,set} - V_{desired}}{V_{o,set}} \right) \times 100$$

For example, to trim-down the output voltage of 12V module(CHB150W8-36S12) by 5% to 11.4V, $R_{trim-down}$ is calculated as follow:

$\Delta\%=5\%$

$$R_{trim_down} = 20 * \frac{(12 - 5\% * 12 - 1.24)}{5\% * 12} - 100 K\Omega$$

$$R_{trim_down} = 238.7 K\Omega$$

Connecting an external resistor ($R_{trim-up}$) between the Trim pin and the V_{out} (-) (or Sense (-)) pin increases the output voltage. The following equations determine the required external resistor value to obtain a up percentage output voltage change of $\Delta\%$.

$V_{out}=12V, 15V$

$$R_{trim_up} = 20 * \frac{(1.24 - \frac{0.46 * 100}{100 + 4.3})}{\Delta\% * V_{o,set}} - \frac{4.3 * 100}{100 + 4.3} K\Omega$$

$V_{out}=24V$

$$R_{trim_up} = 20 * \frac{(2.5 - \frac{0.46 * 100}{100 + 5.6})}{\Delta\% * V_{o,set}} - \frac{5.6 * 100}{100 + 5.6} K\Omega$$

$V_{out}=28V$

$$R_{trim_up} = 23.7 * \frac{(2.5 - \frac{0.46 * 150}{150 + 5.6})}{\Delta\% * V_{o,set}} - \frac{5.6 * 150}{150 + 5.6} K\Omega$$

$V_{out}=48V$

$$R_{trim_up} = 36 * \frac{(2.5 - \frac{0.46 * 200}{200 + 5.1})}{\Delta\% * V_{o,set}} - \frac{5.1 * 200}{200 + 5.1} K\Omega$$

Where

$$V_{out} = V_{o,set}, \Delta\% = \left(\frac{V_{desired} - V_{o,set}}{V_{o,set}} \right) \times 100$$

For example, to trim-up the output voltage of 12V module(CHB150W8-36S12) by 5% to 12.6V, $R_{trim-up}$ is calculated as follow:

$\Delta\%=5\%$

$$R_{trim_up} = 20 * \frac{(1.24 - \frac{0.46 * 100}{100 + 4.3})}{5\% * 12} - \frac{4.3 * 100}{100 + 4.3} K\Omega$$

$$R_{trim_up} = 22.5 K\Omega$$

Note: Although the output voltage can be increased by both the remote sense and by the trim, the maximum increase for the output voltage is not the sum of both. The maximum increase is the larger of either the remote sense or the trim. The amount of power delivered by the module is defined as the voltage at the output terminals multiplied by the output current. When using remote sense and trim, the output voltage of the module can be increased and consequently increase the power output of the module if output current remains unchanged. Care should be taken to ensure that the maximum output power of the module remains at or below the maximum rated power (Maximum rated power = $V_{o,set} \times I_{o,max}$). The output voltage on 12V&15V&24V&48V models is adjustable within the range of +10% to -10%. For 28V models, see input & output trim curves for trim up and trim down is -10%.

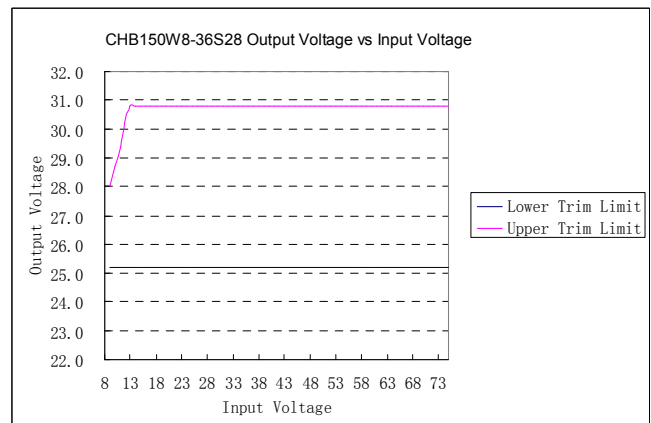



CHB150W8 Series Application Note V13 February 2020

6.9 Output Ripple and Noise

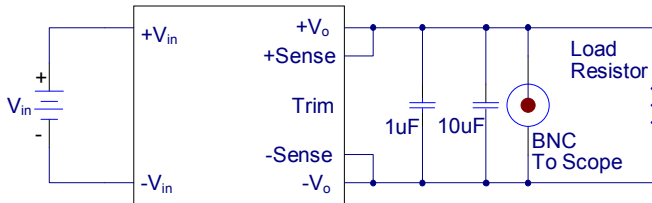

Output ripple and noise is measured with 10uF solid tantalum capacitors (for 48V_{out} with 10uF Aluminum) and 1.0uF ceramic across the output. CINCON's representative.

6.10 Output Capacitance

For good transient response, low ESR output capacitors should be located close to the point of load. PCB design emphasizes low resistance and inductance tracks in consideration of high current applications. Output capacitors with their associated ESR values have an impact on loop stability and bandwidth. The minimum output capacitance is 100uF which need three or four times capacitance when operating below -20°C and the absolute maximum value of CHB150W8 series' output capacitance, please refer to Page 5 Maximum Output Capacitance. For values larger than this, please contact your local

7. Safety & EMC

7.1 Input Fusing and Safety Considerations

The CHB150W8 series converters have no internal fuse. In order to achieve maximum safety and system protection, always use an input line fuse. We recommended a 30A fast acting fuse for 36V_{in} models, It is recommended that the circuit have a transient voltage suppressor diode (TVS) across the input terminal to protect the unit against surge or spike voltage and input reverse voltage (as shown).

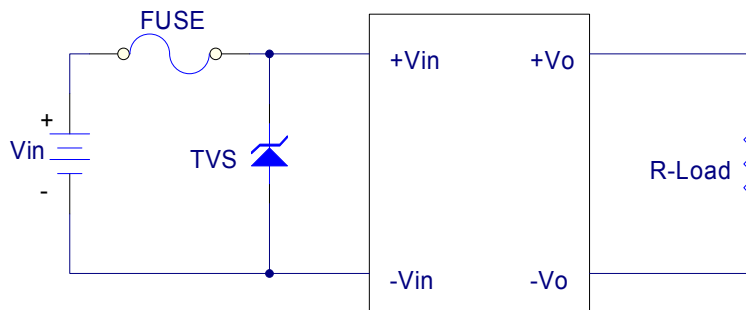

7.2 EMC Considerations

EMI Test standard: EN55022 Class A and Class B Conducted Emission
Test Condition: Input Voltage: Nominal, Output Load: Full Load

(1) EMI and conducted noise meet EN55022 Class A:

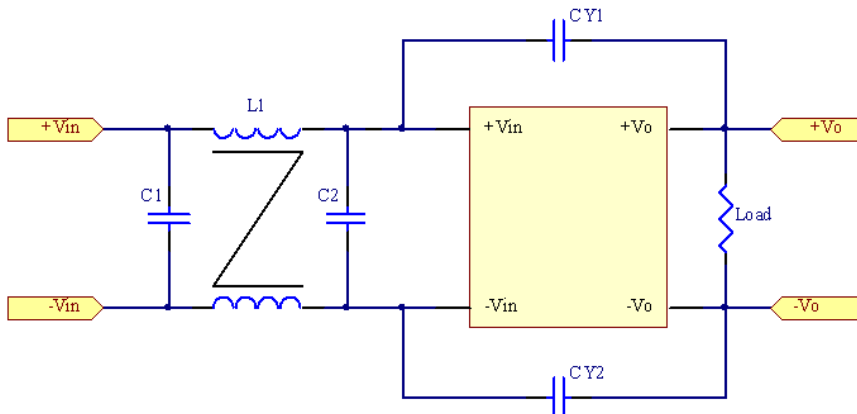

Figure1 Connection circuit for conducted EMI Class A testing



CHB150W8 Series

Application Note V13 February 2020

Model No.	C1	C2	CY1	CY2	L1
CHB150W8-36S12	220uF/100V	220uF/100V	1500pF	1500pF	0.2mH
CHB150W8-36S15	220uF/100V	220uF/100V	1500pF	1500pF	0.2mH
CHB150W8-36S24	220uF/100V	220uF/100V	1500pF	1500pF	0.2mH
CHB150W8-36S28	220uF/100V	220uF/100V	1500pF	1500pF	0.2mH
CHB150W8-36S48	220uF/100V	220uF/100V	1500pF	1500pF	0.2mH

Note: C1, C2 NICHICON PW series aluminum capacitors, CY1, CY2 is ceramic capacitors, L1 Core use SM CM20*12*10 Winding 5turns (double wire).

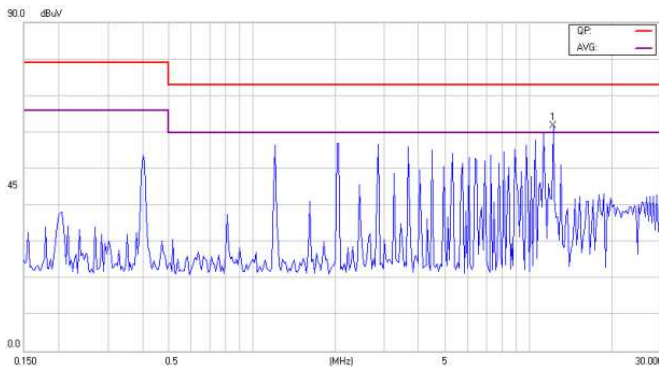

Conducted Class A CHB150W8-36S12

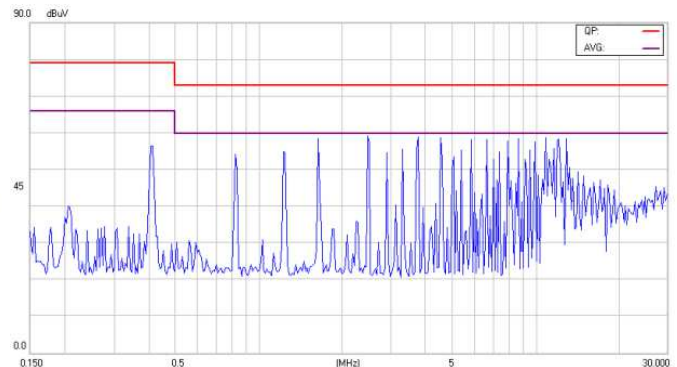

Conducted Class A of CHB150W8-36S15

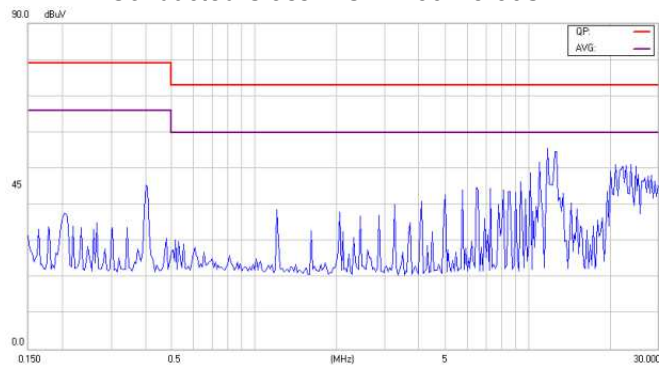

Conducted Class A of CHB150W8-36S24

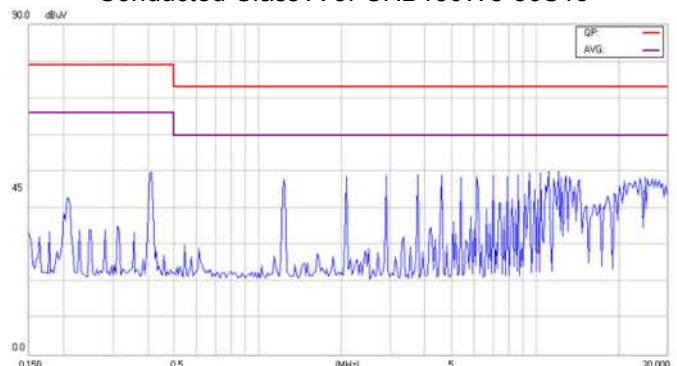

Conducted Class A of CHB150W8-36S28

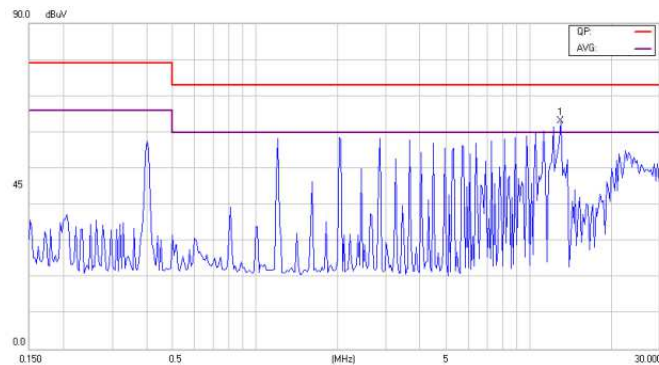

Conducted Class A of CHB150W8-36S48



CHB150W8 Series

Application Note V13 February 2020

8. Part Number

Format: CHB150W8 – 36 X OO L

Parameter	Series	Nominal Input Voltage	Number of Outputs	Output Voltage	Remote ON/OFF Logic
Symbol	CHB150W8	36	X	OO	L
Value	CHB150W8	36: 36 Volts	S: Single	12: 12 Volts 15: 15 Volts 24: 24 Volts 28: 28 Volts 48: 48 Volts	None: Positive N: Negative

9. Mechanical Specifications

9.1 Mechanical Outline Diagrams

CASE HB

All Dimensions In Inches(mm)

Tolerances Inches: X.XX= ±0.02 , X.XXX= ±0.010

Millimeters: X.X= ±0.5 , X.XX=±0.25

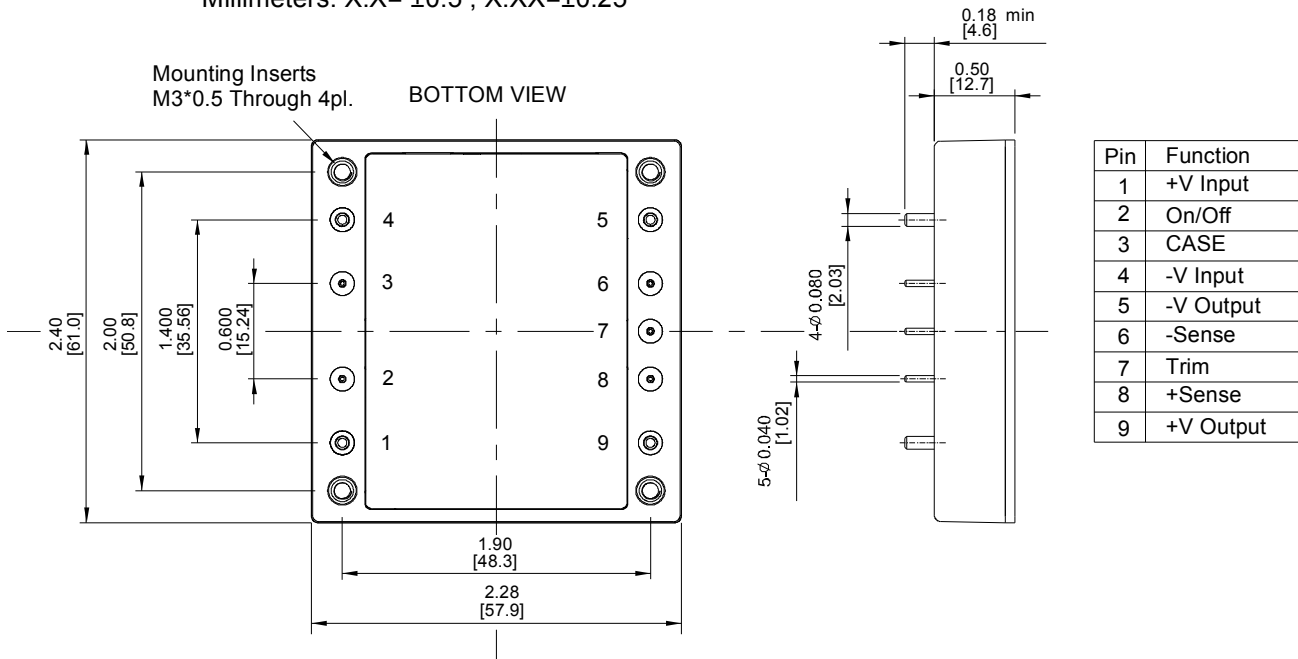

CINCON ELECTRONICS CO., LTD.

Headquarters:

14F, No.306, Sec.4, Hsin Yi Rd.
 Taipei, Taiwan
 Tel: 886-2-27086210
 Fax: 886-2-27029852
 E-mail: support@cincon.com.tw
 Web Site: <http://www.cincon.com>

Factory:

No. 8-1, Fu Kung Rd.
 Fu Hsing Industrial Park
 Fu Hsing Hsiang,
 Chang Hua Hsien, Taiwan
 Tel: 886-4-7690261
 Fax: 886-4-7698031

Cincon North America:

1655 Mesa Verde Ave. Ste 180
 Ventura, CA 93003
 Tel: 805-639-3350
 Fax: 805-639-4101
 E-mail: info@cincon.com