



# CHB150W12 Series Application Note V10

## ISOLATED DC-DC CONVERTER CHB150W12 SERIES APPLICATION NOTE



### Approved By:

Department	Approved By	Checked By	Written By
Research and Development Department	Enoch	Astray	Elsie
		Jacky	
Quality Assurance Department	Ryan	Benny	



# CHB150W12 Series Application Note V10

## Contents

1. Introduction .....	3
2. Pin Function Description .....	3
3. Connection for Standard Use .....	4
4. Test Set-Up .....	4
5. Recommend Layout, PCB Footprint and Soldering Information .....	4
6. Features and Functions.....	5
6.1 UVLO (Under Voltage Lock Out) .....	5
6.2 Over Current / Short Circuit Protection .....	6
6.3 Output Over Voltage Protection .....	6
6.4 Over Temperature Protection.....	6
6.5 Remote On/Off.....	6
6.6 Output Remote Sensing.....	7
6.7 Output Voltage Adjustment .....	8
7. Input / Output Considerations.....	9
7.1 Input Capacitance at the Power Module .....	9
7.2 Hold Up Time .....	9
7.3 Input Derating Curve .....	10
7.4 Output Ripple and Noise .....	10
7.5 Output Capacitance .....	10
7.6 Output Ripple Frequency Synchronized .....	11
8. Series and Parallel Operation .....	11
8.1 Series Operation .....	11
8.2 Parallel Operation .....	11
8.3 Redundant Operation.....	12
9. Thermal Design.....	13
9.1 Operating Temperature Range .....	13
9.2 Convection Requirements for Cooling .....	13
9.3 Thermal Considerations.....	13
9.4 Power Derating .....	13
9.5 Half Brick Heat Sinks: .....	15
10. Safety & EMC.....	16
10.1 Input Fusing and Safety Considerations.....	16
10.2 EMC Considerations .....	16
10.3 Suggested Configuration for RIA12 Surge Test .....	23



# CHB150W12 Series Application Note V10

## 1. Introduction

The CHB150W12 series of DC-DC converters offers 150 watts of output power @ single output voltages of 5,12, 15, 24, 48VDC with industry standard Half-brick. It has a wide (12:1) input voltage range of 14 to 160VDC (72VDC nominal) and 3000VAC reinforced isolation.

Compliant with EN50155, EN45545, EN50121-3-2. High efficiency up to 91%, allowing case operating temperature range of  $-40^{\circ}\text{C}$  to  $100^{\circ}\text{C}$ . An optional heat sink is available to extend the full power range of the unit.

The standard control functions include remote on/off (positive or negative) and +15%, -20% adjustable output voltage.

Fully protected against input UVLO (under voltage lock out), output over-current, output over-voltage and over-temperature and continuous short circuit conditions.

CHB150W12 series is designed primarily for common railway applications of 24V, 36V, 48V, 72V, 96V, 110V nominal voltage and also suitable for distributed power architectures, telecommunications, battery operated equipment and industrial applications.

## 2. Pin Function Description

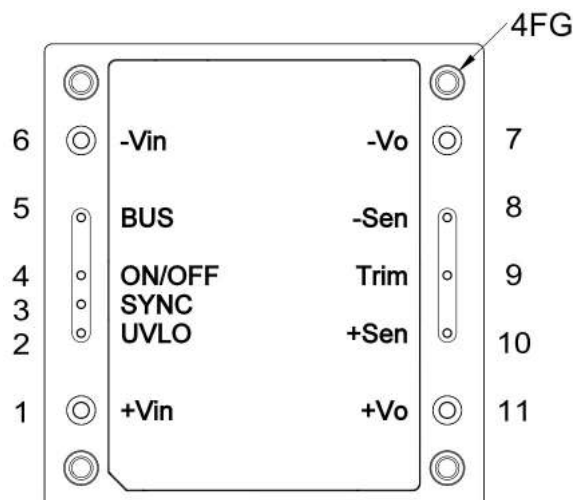

No	Label	Function	Description	Reference
1	+Vin	+V Input	Positive Supply Input	<b>Section 7.1/7.2/ 7.3</b>
2	UVLO	UVLO	Under Voltage Lock Out	<b>Section 6.1</b>
3	SYNC	Synchronized	Output Ripple Frequency Synchronized	<b>Section 7.6</b>
4	ON/OFF	On/Off	External Remote On/Off Control	<b>Section 6.5</b>
5	BUS	BUS	Pre-Regulator Voltage Output	<b>Section 7.2</b>
6	-Vin	-V Input	Negative Supply Input	<b>Section 7.1/7.2/7.3</b>
7	-Vo	-V Output	Negative Power Output	<b>Section 7.4/7.5</b>
8	-Sen	-Sense	Negative Output Remote Sense	<b>Section 6.6</b>
9	Trim	Trim	External Output Voltage Adjustment	<b>Section 6.7</b>
10	+Sen	+Sense	Positive Output Remote Sense	<b>Section 6.6</b>
11	+Vo	+V Output	Positive Power Output	<b>Section 7.4/7.5</b>
12	--	Mounting Insert	Mounting Insert (FG)	<b>Section 9.5/10.2</b>

Note: Base plate can be connected to FG through M3 threaded mounting insert. Recommended torque 3Kgf-cm.



# CHB150W12 Series Application Note V10

## 3. Connection for Standard Use

The connection for standard use is shown below. An external input capacitor (C1) 100uF for all models is recommended to reduce input ripple voltage. The BUS capacitor (C4) is recommended to set 240uF (VISHAY 118 AHT series). External output capacitors (C2, C3) are recommended to reduce output ripple and noise, 10uF aluminum and 1uF ceramic capacitors for 48Vout, and 10uF tantalum and 1uF ceramic capacitors for other models.

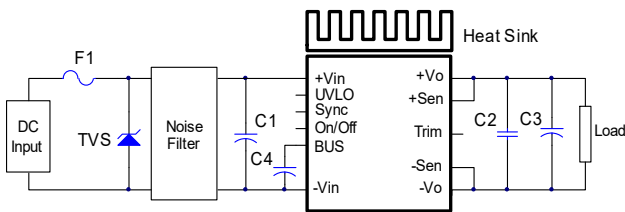

Symbol	Component	Reference
F1, TVS	Input fuse, TVS	<b>Section 10.1</b>
C1	External capacitor on the input side	<b>Section 7.2</b>
C2,C3	External capacitor on the output side	<b>Section 7.4/7.5</b>
C4	External capacitor connected between BUS and -Vin is necessary to keep operating stable	<b>Section 7.1/7.2</b>
Noise Filter	External input noise filter	<b>Section 10.2</b>
UVLO	External UVLO adjustment	<b>Section 6.1</b>
Sync	External clock frequency sync	<b>Section 7.6</b>
Remote On/Off	External Remote On/Off control	<b>Section 6.5</b>
BUS	External Hold up Time	<b>Section 7.2</b>
Trim	External output voltage adjustment	<b>Section 6.7</b>
Heat sink	External heat sink	<b>Section 9.2/9.3/9.4/9.5</b>
+Sense/-Sense	--	<b>Section 6.6</b>

### Note:

If the impedance of input line is high, C1, C4 capacitance must be more than above. Use more than two recommended capacitors above in parallel when ambient temperature becomes lower than -20 °C.

## 4. Test Set-Up

The basic test set-up to measure parameters such as efficiency and load regulation is shown below. When testing the modules under any transient conditions please ensure that the transient response of the source

is sufficient to power the equipment under test. We can calculate:

- Efficiency
- Load regulation and line regulation.

The value of efficiency is defined as:

$$\eta = \frac{V_o \times I_o}{V_{in} \times I_{in}} \times 100\%$$

Where:

- V<sub>o</sub> is output voltage,
- I<sub>o</sub> is output current,
- V<sub>in</sub> is input voltage,
- I<sub>in</sub> is input current.

The value of load regulation is defined as:

$$\text{Load reg.} = \frac{V_{FL} - V_{NL}}{V_{NL}} \times 100\%$$

Where:

- V<sub>FL</sub> is the output voltage at full load.
- V<sub>NL</sub> is the output voltage at no load.

The value of line regulation is defined as:

$$\text{Line reg.} = \frac{V_{HL} - V_{LL}}{V_{LL}} \times 100\%$$

Where:

- V<sub>HL</sub> is the output voltage of maximum input voltage at full load.
- V<sub>LL</sub> is the output voltage of minimum input voltage at full load.

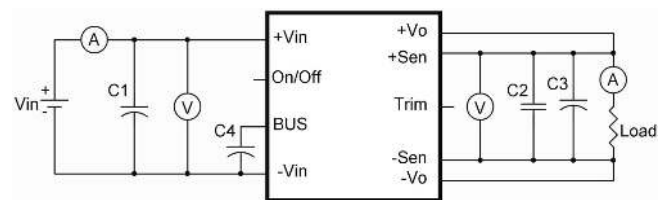

CHB150W12 Series Test Setup

C1: 100uF/200V ESR<0.047Ω

C2: 1uF/1210 ceramic capacitor

C3: 10uF tantalum capacitor.(10uF aluminum for 48Vout).

C4 : 240uF (VISHAY 118 AHT series)

## 5. Recommend Layout, PCB Footprint and Soldering Information

The system designer or end user must ensure that metal and other components in the vicinity of the converter meet the spacing requirements for which the system is approved. Low resistance and inductance PCB layout traces are the norm and should be used where possible. Due consideration must also be given to proper low impedance tracks between power module, input and output grounds.



# CHB150W12 Series Application Note V10

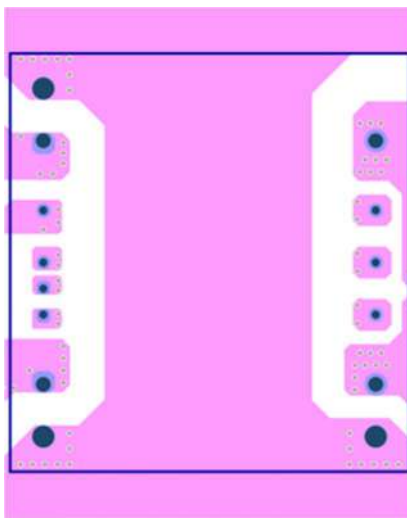
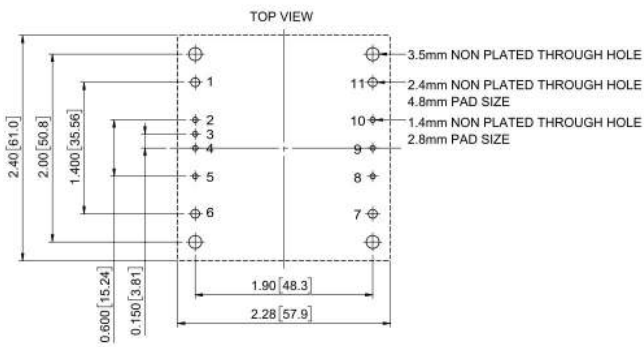

Clean the soldered side of the module with a brush, prevent liquid from getting into the module. Do not clean by soaking the module into liquid. Do not allow solvent to come in contact with product labels or resin case as this may change the color of the resin case or cause deletion of the letters printed on the product label. After cleaning, dry the modules well.

The suggested soldering iron is  $420 \pm 10^\circ\text{C}$  for up to 4~15 seconds (less than 90W). Furthermore, the recommended soldering profile is shown below, and PCB layout is referring to Section 10.2.

Lead Free Wave Soldering Profile

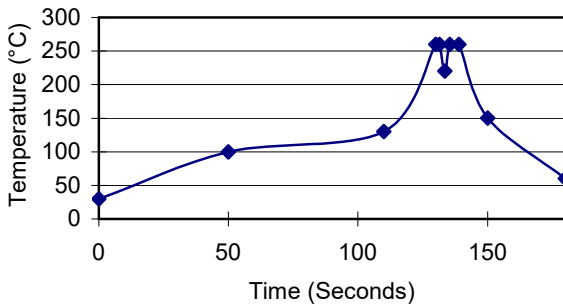

## 6. Features and Functions

### 6.1 UVLO (Under Voltage Lock Out)

Input under voltage lockout is standard on the CHB150W12 series unit. The unit will shut down when the input voltage drops below a lower threshold, and the unit will operate when the input voltage goes above the upper threshold.

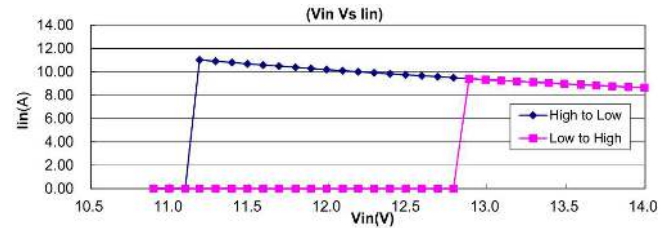

And the CHB150W12 series has an adjustable under voltage lockout which will shut down the converter according to following settings.

Nom. Input Voltage(VDC)	24	36	48	72	110
Turn Off Threshold(VDC)	11.0±0.5	20.0±1.0	27.3±1.0	41.6±1.0	53.0±1.0
Turn On Threshold(VDC)	13.0±0.5	22.0±1.0	29.6±1.0	44.6±1.0	58.0±1.0
Radj Resistor(KΩ) (UVLO to -Vin)	Open	62	34	18	10

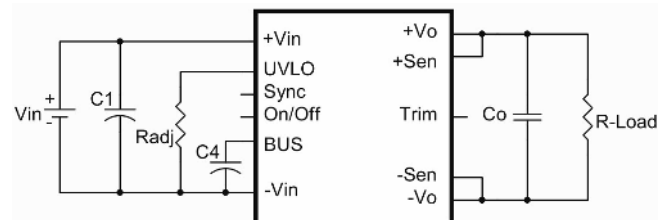

C1: 100uF/200V ESR<0.047Ω

C4 : 240uF (VISHAY 118 AHT series)

Note: If need to configure UVLO turn off threshold to 11V, please make sure the output power is no more than 100W, even though the 11V operating is short duration.

And the module operating between input 14Vdc to 16.5Vdc, please make sure the output power is no more than 100W.



# CHB150W12 Series Application Note V10

## 6.2 Over Current / Short Circuit Protection

All models have internal over current and continuous short circuit protection. The unit operates normally once the fault condition is removed. At the point of current limit inception, the converter will go into hiccup mode protection.

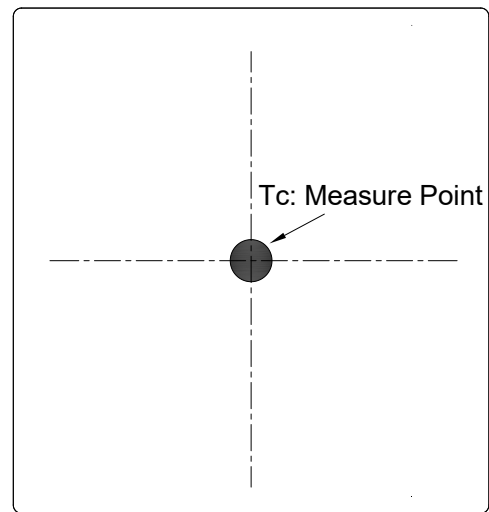
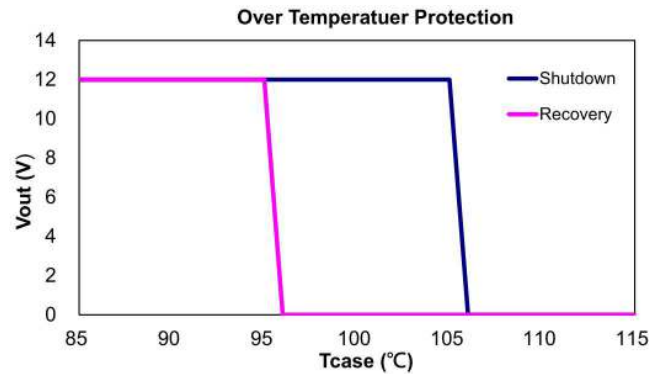
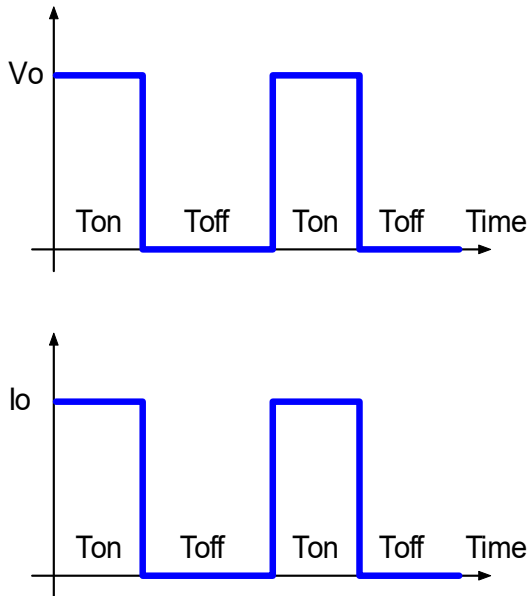

## 6.3 Output Over Voltage Protection

The output over voltage protection consists of circuitry that internally limits the output voltage. If more accurate output over voltage protection is required, then an external circuit can be used via the remote on/off pin.

**Note:** Please note that device inside the power supply might fail when voltage more than rated output voltage is applied to output pin. This could happen when the customer tests the over voltage protection of unit. OVP can be tested by using the Trim up function. Consult us for more information.

## 6.4 Over Temperature Protection

These modules have an over temperature protection circuit to safeguard against thermal damage. Shutdown occurs with the maximum case reference temperature is exceeded. The module will restart when the case temperature falls below over temperature recovery threshold. Please measure case temperature of the center part of aluminum base plate.

## 6.5 Remote On/Off

The CHB150W12 series allows the user to switch the module on and off electronically with the remote On/Off feature. All models are available in "positive logic" and "negative logic" (optional) versions. The converter turns on if the remote On/Off pin is high (>3.5Vdc to 160Vdc or open circuit). Setting the pin low (0 to <1.2Vdc) will turn the converter off. The signal level of the remote On/Off input is defined with respect to ground. If not using the remote On/Off pin, leave the pin open (converter will be on).

Models with part number suffix "N" are the "negative logic" remote On/Off version. The unit turns off if the remote On/Off pin is high (>3.5Vdc to 160Vdc or open circuit). The converter turns on if the On/Off pin input is low (0 to <1.2Vdc). Note that the converter is off by default.

Logic State (Pin 4)	Negative Logic	Positive Logic
Logic Low	Module on	Module off
Logic High	Module off	Module on

The converter remote On/Off circuit built-in on input side. The ground pin of input side Remote On/Off circuit is -Vin pin. Inside connection see below.



# CHB150W12 Series Application Note V10

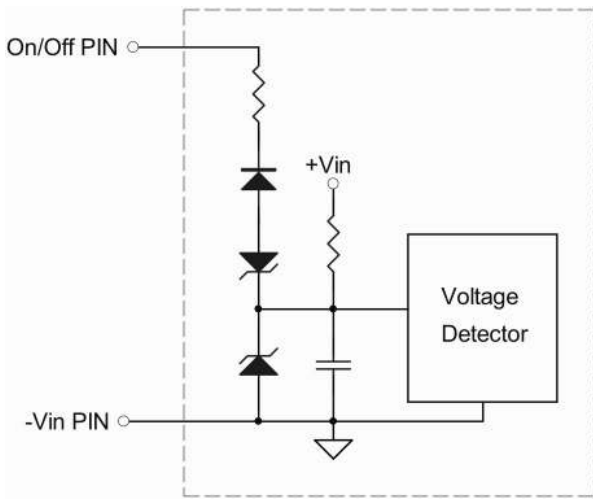

Connection examples see below

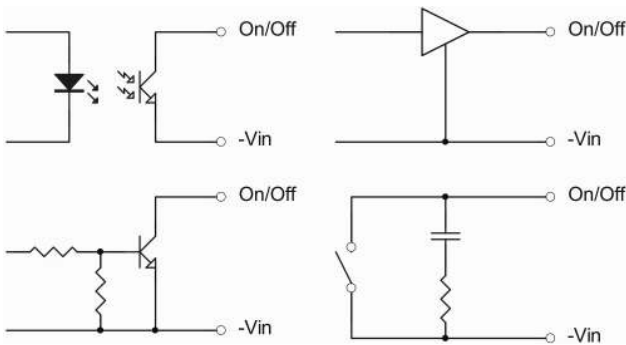

Remote On/Off Connection Examples

## 6.6 Output Remote Sensing

The CHB150W12 series converter has the capability to remotely sense both lines of its output. This feature moves the effective output voltage regulation point from the output of the unit to the point of connection of the remote sense pins. This feature automatically adjusts the real output voltage of the CHB150W12 series in order to compensate for voltage drops in distribution and maintain a regulated voltage at the point of load. The remote sense voltage range is:

$$[(+V_{out}) - (-V_{out})] - [(+Sense) - (-Sense)] \leq 15\% \text{ of } V_{o\_nominal}$$

When remote sense is in use, the sense should be connected by twisted-pair wire or shield wire. If the sensing patterns short, heavy current flows and the pattern may be damaged. Output voltage might become unstable because of impedance of wiring and load condition when length of wire is exceeding 400mm. This is shown in the schematic below.

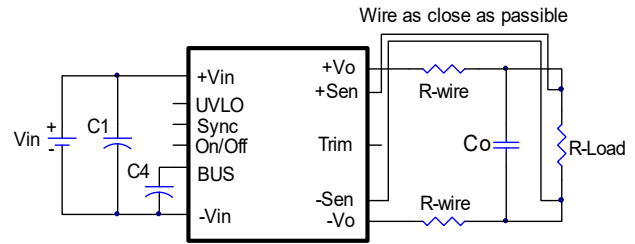

If the remote sense feature is not to be used, the sense pins should be connected locally. The +Sense pin should be connected to the +Vout pin at the module and the -Sense pin should be connected to the -Vout pin at the module. Wire between +Sense and +Vout and between -Sense and -Vout as short as possible. Loop wiring should be avoided. The converter might become unstable by noise coming from poor wiring. This is shown in the schematic below.

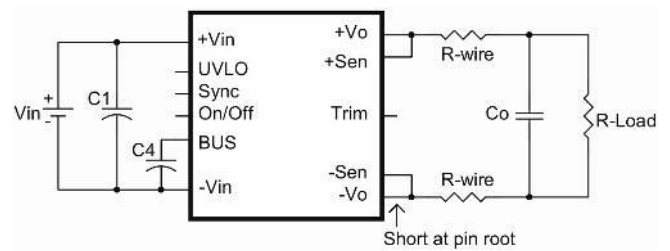

**Note:** Although the output voltage can be varied (increased or decreased) by both remote sense and trim, the maximum variation for the output voltage is the larger of the two values not the sum of the values. The output power delivered by the module is defined as the voltage at the output terminals multiplied by the output current. Using remote sense and trim can cause the output voltage to increase and consequently increase the power output of the module if output current remains unchanged. Always ensure that the output power of the module remains at or below the maximum rated power. Also be aware that if  $V_{o\_set}$  is below nominal value,  $P_{out\_max}$  will also decrease accordingly because  $I_{o\_max}$  is an absolute limit. Thus,  $P_{out\_max} = V_{o\_set} \times I_{o\_max}$  is also an absolute limit.



# CHB150W12 Series Application Note V10

## 6.7 Output Voltage Adjustment

Output may be externally trimmed (-20% to +15%) with a fixed resistor or an external trim pot as shown (optional). Model specific formulas for calculating trim resistors are available upon request as a separate document.

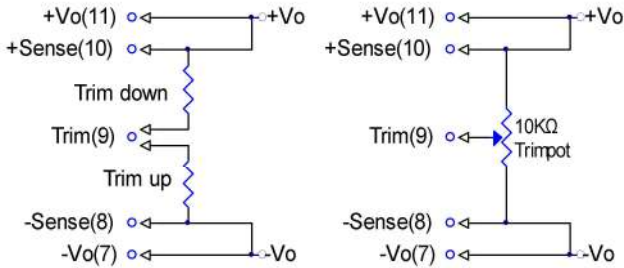

In order to trim the voltage up or down, one needs to connect the trim resistor either between the trim pin and -Sense for trim-up or between trim pin and +Sense for trim-down. The output voltage trim range is -20% to +15%. This is shown:

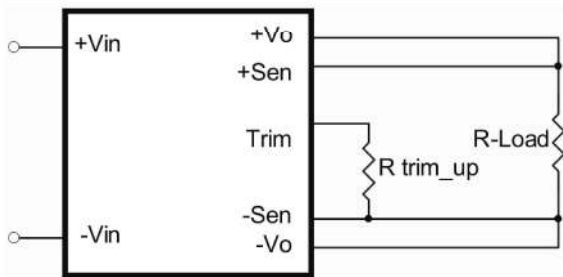

Trim-up Voltage Setup

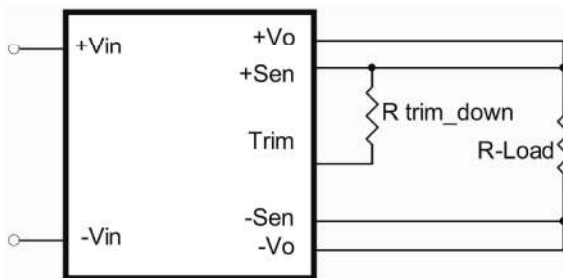

Trim-down Voltage Setup

**The value of  $R_{trim\_up}$  defined as:**

$$R_{trim\_up} = \left[ \frac{V_r \times R1 \times (R2 + R3)}{R2 \times (V_o - V_{o,nom})} \right] - R_t \text{ (K}\Omega\text{)}$$

Where:

- $R_{trim\_up}$  is the external resistor in  $K\Omega$ .
- $V_{o,nom}$  is the nominal output voltage.
- $V_o$  is the desired output voltage.
- $R1, R2, R3, R_t$  and  $V_r$  are internal to the unit and are defined in Table 1.

Table 1 – Trim up and Trim down Resistor Values

Model Number	Output Voltage(V)	R1 (K $\Omega$ )	R2 (K $\Omega$ )	R3 (K $\Omega$ )	Rt (K $\Omega$ )	Vr (V)
CHB150W12-72S05	5.0	6.2	2.37	1	8.2	1.24
CHB150W12-72S12	12.0	6.8	2.37	2.2	10	2.5
CHB150W12-72S15	15.0	9.1	2.32	2.49	12	2.5
CHB150W12-72S24	24.0	15	2.43	5.9	20	2.5
CHB150W12-72S48	48.0	28.7	2.4	15	43.2	2.5

For example, to trim-up the output voltage of 12V module (CHB150W12-72S12) by 15% to 13.8V,  $R_{trim\_up}$  is calculated as follows:

$$R1=6.8K\Omega, R2=2.37K\Omega, R3=2.2K\Omega, R_t=10K\Omega, V_r=2.5V, V_o=13.8V, V_{o,nom}=12V$$

$$R_{trim\_up} = \left[ \frac{2.5 \times 6.8 \times (2.37 + 2.2)}{2.37 \times (13.8 - 12)} \right] - 10 = 8.21 \text{ (K}\Omega\text{)}$$

**The typical value of  $R_{trim\_up}$**

Trim up (%)	5V	12V	15V	24V	48V
	$R_{trim\_up}$ (K $\Omega$ ) DC				
1%	210.44	263.17	302.45	515.62	1040.52
2%	101.12	126.59	145.22	247.81	498.66
3%	64.68	81.06	92.82	158.54	318.04
4%	46.46	58.29	66.61	113.91	227.73
5%	35.53	44.63	50.89	87.12	173.54
6%	28.24	35.53	40.41	69.27	137.42
7%	23.03	29.02	32.92	56.52	111.62
8%	19.13	24.15	27.31	46.95	92.27
9%	16.09	20.35	22.94	39.51	77.21
10%	13.66	17.32	19.44	33.56	65.17
11%	11.68	14.83	16.59	28.69	55.32
12%	10.02	12.76	14.20	24.64	47.11
13%	8.62	11.01	12.19	21.20	40.16
14%	7.42	9.51	10.46	18.26	34.21
15%	6.38	8.21	8.96	15.71	29.05

**The value of  $R_{trim\_down}$  defined as:**

$$R_{trim\_down} = R1 \times \left[ \frac{V_r \times R1}{R2 \times (V_{o,nom} - V_o)} - 1 \right] - R_t \text{ (K}\Omega\text{)}$$

Where:

- $R_{trim\_down}$  is the external resistor in  $K\Omega$ .
- $V_{o,nom}$  is the nominal output voltage.
- $V_o$  is the desired output voltage.
- $R1, R2, R3, R_t$  and  $V_r$  are internal to the unit and are defined in Table 1.



# CHB150W12 Series Application Note V10

For example: to trim-down the output voltage of 48V module (CHB150W12-72S48) by 20% to 38.4V,  $R_{trim\_down}$  is calculated as follows:

$$R1=28.7K\Omega, R2=2.4K\Omega, R3=15K\Omega, Rt=43.2K\Omega, Vr=2.5V, Vo=38.4V, Vo, nom=48V$$

$$R_{trim\_down} = 28.7 \times \left[ \frac{2.5 \times 28.7}{2.4 \times (48 - 38.4)} - 1 \right] - 43.2 = 17.48 (K\Omega)$$

## The typical value of $R_{trim\_down}$

Trim down (%)	$R_{trim\_down} (K\Omega)$				
	5V	12V	15V	24V	48V
1%	387.84	389.67	573.80	929.51	1715.62
2%	186.72	186.43	276.35	447.25	821.86
3%	119.68	118.69	177.20	286.50	523.94
4%	86.16	84.82	127.62	206.13	374.98
5%	66.05	64.49	97.88	157.90	285.60
6%	52.64	50.94	78.05	125.75	226.02
7%	43.06	41.27	63.89	102.79	183.46
8%	35.88	34.01	53.26	85.56	151.54
9%	30.29	28.36	45.00	72.17	126.71
10%	25.82	23.85	38.39	61.45	106.85
11%	22.17	20.15	32.98	52.68	90.60
12%	19.12	17.07	28.47	45.38	77.06
13%	16.54	14.47	24.66	39.19	65.60
14%	14.33	12.23	21.39	33.89	55.78
15%	12.42	10.30	18.56	29.30	47.27
16%	10.74	8.60	16.08	25.28	39.82
17%	9.26	7.11	13.89	21.74	33.25
18%	7.95	5.78	11.95	18.58	27.41
19%	6.77	4.59	10.21	15.76	22.18
20%	5.71	3.52	8.64	13.23	17.48

## 7. Input / Output Considerations

### 7.1 Input Capacitance at the Power Module

The converters must be connected to low AC source impedance. To avoid problems with loop stability source inductance should be low. Also, the input capacitors ( $C_{in}$ ) should be placed close to the converter input pins to decouple distribution inductance. However, the external input capacitors are chosen for suitable ripple handling capability. Low ESR capacitors are good choice. Circuit as shown as below represents typical measurement methods for reflected ripple current.  $C1$  and  $L1$  simulate a typical DC source impedance. The input reflected-ripple current is measured by current probe to oscilloscope with a simulated source inductance ( $L1$ ).

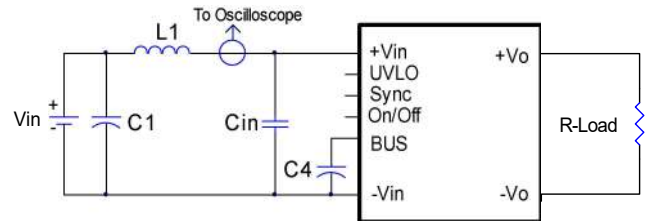

- L1: 12uH
- C1: 220uF ESR<0.047ohm @100KHz
- $C_{in}$ : 220uF ESR<0.047ohm @100KHz
- C4: 240uF (VISHAY 118 AHT series)

### 7.2 Hold Up Time

Hold up time is defined as the duration of time that the DC/DC converter output will remain active following a loss of input power. The BUS pin is for hold up time function. It is designed to work with an external circuit comprises  $C5$ ,  $R1$ ,  $D1$ . When input power supply is interrupt, the CHB150W12-72S series use the energy stored in  $C5$  to support operation.

A typical configuration shows as below.

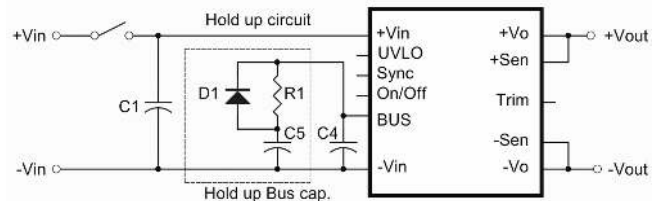

- C1: 100uF/200V ESR<0.047Ω
- C4: 240uF (VISHAY 118 AHT series)
- D1: 200V/10A
- R1: 3mΩ/1W

If hold up time function is not needed, please remove the 3 components. This function provides energy that maintains the DC-DC converter in operation for 10mS and 30mS hold up time. The capacity ( $C5$ ) in the application is recommended as below.

$C5$ \ $V_{in}$	24V	36V	48V	72V	96V	110V
For 10 mS	2400uF	2400uF	2400uF	2400uF	820uF	560uF
For 30 mS	7200uF	7200uF	7200uF	7200uF	2460uF	1680uF

The BUS voltage and input voltage curve is showed as below. The red curve, BUS keeps stable at 73V when input voltage rise from 14V to 73V, when the input voltage is above 73V, then BUS follows input voltage. The blue curve, BUS falls with input voltage until the input voltage falls to 70V, then BUS will maintain 73V until input voltage falls below the UVLO.



# CHB150W12 Series Application Note V10

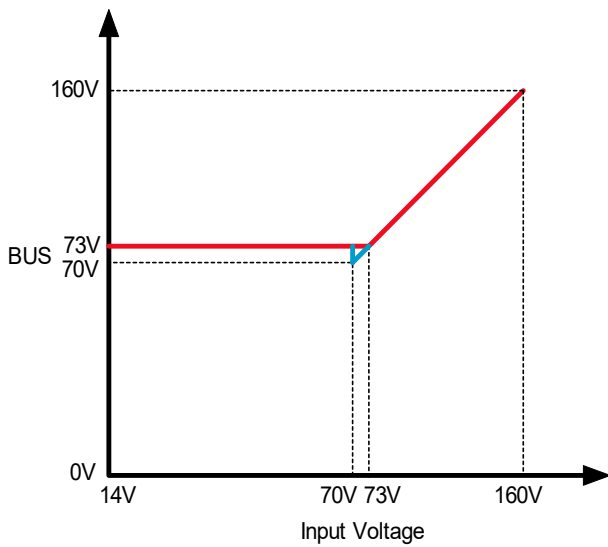

Output ripple and noise measured with 10uF tantalum capacitor (10uF aluminum capacitor for 48Vout) and 1uF ceramic capacitors across output. A 20 MHz bandwidth oscilloscope is normally used for the measurement.

The conventional ground clip on an oscilloscope probe should never be used in this kind of measurement. This clip, when placed in a field of radiated high frequency energy, acts as an antenna or inductive pickup loop, creating an extraneous voltage that is not part of the output noise of the converter.



Another method is shown in below, in case of coaxial-cable/BNC is not available. The noise pickup is eliminated by pressing scope probe ground ring directly against the -Vout terminal while the tip contacts the +Vout terminal. This makes the shortest possible connection across the output terminals.

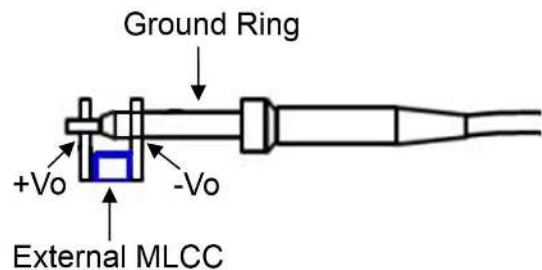

### 7.3 Input Derating Curve

CHB150W12 series has derating by input voltage is required shown below.

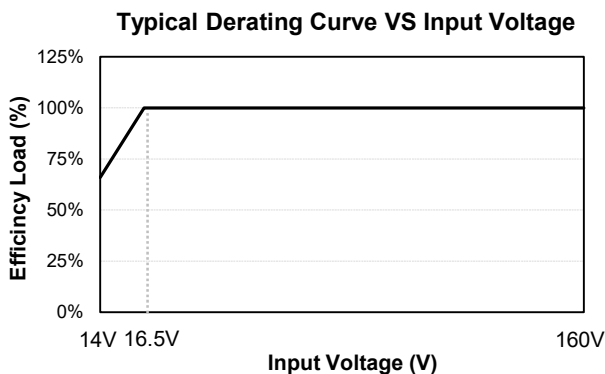

### 7.4 Output Ripple and Noise

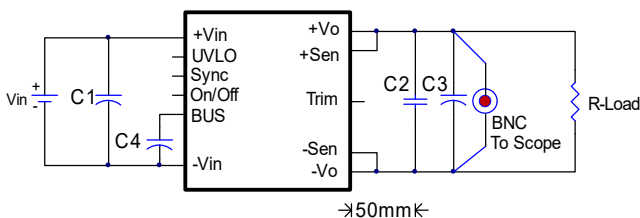

- C1: 100uF/200V ESR<0.047Ω
- C2: 1uF/1210 ceramic capacitor
- C3: 10uF tantalum capacitor.(10uF aluminum for 48Vout).
- C4: 240uF (VISHAY 118 AHT series)

### 7.5 Output Capacitance

The CHB150W12 series converters provide unconditional stability with or without external capacitors. For good transient response, low ESR output capacitors should be located close to the point of load (<100mm). PCB design emphasizes low resistance and inductance tracks in consideration of high current applications. Output capacitors with their associated ESR values have an impact on loop stability and bandwidth. Cincon's converters are designed to work with load capacitance to see specifications.



# CHB150W12 Series Application Note V10

## 7.6 Output Ripple Frequency Synchronized

The CHB150W12-72SXX can be synchronized to an external clock by applying a narrow pulse to the Sync pin. The external clock must be at 530KHz~630KHz the switching frequency. If the external clock frequency is less than the switching frequency, the CHB150W12-72SXX will ignore the synchronizing pulses. The synchronization pulse width at the Sync pin must be a minimum of 60nS~90nS wide. The clock signal must be parallel Zener 5.6V to the Sync pin. When the synchronizing pulse transitions low-to-high (rising edge), the voltage at the Sync pin must be driven to exceed 3.5V ~ 4.5V level. The connect setting is shown below.

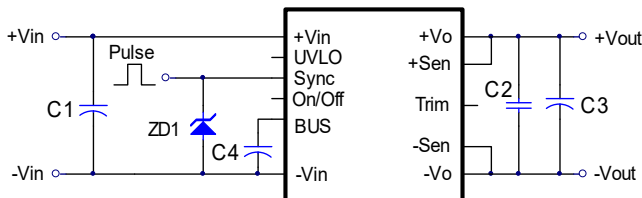

- C1: 100uF/200V ESR<0.047Ω
- C2: 1uF/1210 ceramic capacitor
- C3: 10uF/100V aluminum capacitor.
- C4: 240uF (VISHAY 118 AHT series)
- ZD1: 5.6V Zener

## 8. Series and Parallel Operation

### 8.1 Series Operation

Series operation is possible by connecting the outputs two or more units. Connection is shown in below. The output current in series connection should be lower than the lowest rate current in each power module.

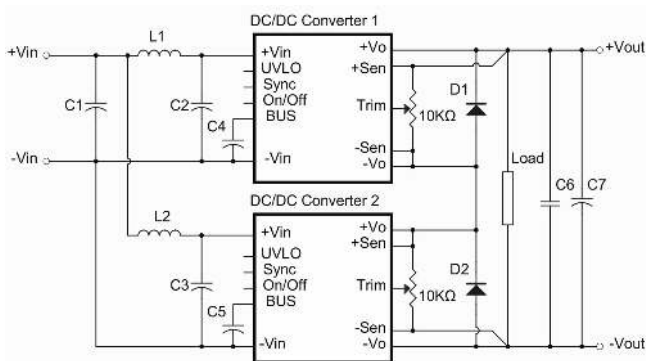

#### Simple Series Operation Connect Circuit

- L1, L2: 1.0uH
- C1, C2, C3: 100uF/200V ESR<0.047Ω
- C4, C5: 240uF (VISHAY 118 AHT series)
- C6: 1uF/1210 ceramic capacitor
- C7: 10uF/200V aluminum capacitor.

### Note:

1. If the impedance of input line is high, C1, C2, C3, C4 and C5 capacitance must be more than above. Use more than two recommended capacitor above in parallel when ambient temperature becomes lower than -20 °C.

2. Recommend Schottky diode(D1,D2) be connected across the output of each series connected converter, so that if one converter shuts down for any reason, then the output stage won't be thermally overstressed. Without this external diode, the output stage of the shut-down converter could carry the load current provided by the other series converters, with its MOSFETs conducting through the body diodes. The MOSFETs could then be overstressed and fail. The external diode should be capable of handling the full load current for as long as the application is expected to run with any unit shut down.

Series for ±output operation is possible by connecting the outputs two units, as shown in the schematic below.

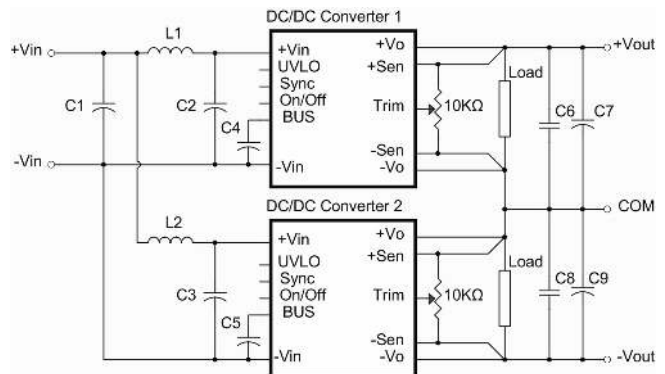

#### Simple ±Output Operation Connect Circuit

- L1, L2: 1.0uH
- C1, C2, C3: 100uF/200V ESR<0.047Ω
- C4, C5: 240uF (VISHAY 118 AHT series)
- C6, C8: 1uF/1210 ceramic capacitor
- C7, C9: 10uF/100V aluminum capacitor

### Note:

If the impedance of input line is high, C1, C2, C3, C4 and C5 capacitance must be more than above. Use more than two recommended capacitor above in parallel when ambient temperature becomes lower than -20 °C.

### 8.2 Parallel Operation

The CHB150W12 series parallel operation is **not** possible.



# CHB150W12 Series Application Note V10

## 8.3 Redundant Operation

Parallel for redundancy operation is possible by connecting the units as shown in the schematic below. The current of each converter become unbalance by a slight difference of the output voltage. Make sure that the output voltage of units of equal value and the output current from each power supply does not exceed the rate current. Suggest use an external potentiometer to adjust output voltage from each power supply.

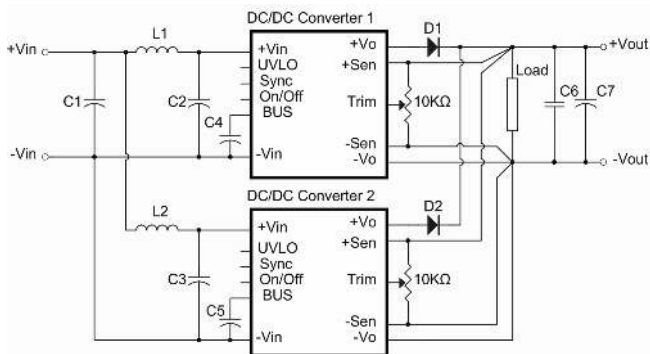

### Simple Redundant Operation Connect Circuit

L1, L2: 1.0uH

C1, C2, C3: 100uF/200V ESR<0.047Ω

C4, C5: 240uF (VISHAY 118 AHT series)

C6: 1uF/1210 ceramic capacitor

C7: 10uF/100V aluminum capacitor

### Note:

If the impedance of input line is high, C1, C2, C3, C4 and C5 capacitance must be more than above. Use more than two recommended capacitor above in parallel when ambient temperature becomes lower than -20 °C.



# CHB150W12 Series Application Note V10

## 9. Thermal Design

### 9.1 Operating Temperature Range

The CHB150W12 series converters can be operated within a wide case temperature range of -40°C to 100°C. Consideration must be given to the derating curves when ascertaining maximum power that can be drawn from the converter. The maximum power drawn from open half brick models is influenced by usual factors, such as:

- Input voltage range
- Output load current
- Forced air or natural convection
- Heat sink optional

### 9.2 Convection Requirements for Cooling

To predict the approximate cooling needed for the half brick module, refer to the power derating curves in **section 9.4**. These derating curves are approximations of the ambient temperatures and airflows required to keep the power module temperature below its maximum rating. Once the module is assembled in the actual system, the module's temperature should be monitored to ensure it does not exceed 100°C as measured at the center of the top of the case (thus verifying proper cooling).

### 9.3 Thermal Considerations

The power module operates in a variety of thermal environments; however, sufficient cooling should be provided to help ensure reliable operation of the unit. Heat is removed by conduction, convection, and radiation to the surrounding environment. The example is presented in **section 9.4**. The power output of the module should not be allowed to exceed rated power ( $V_{o\_set} \times I_{o\_max}$ ).

### 9.4 Power Derating

The operating case temperature range of CHB150W12 series is -40°C to +100°C. When operating the CHB150W12 series, proper derating or cooling is needed. The maximum case temperature under any operating condition should not exceed 100°C.

The following curve is the de-rating curve of CHB150W12 series without heat sink.

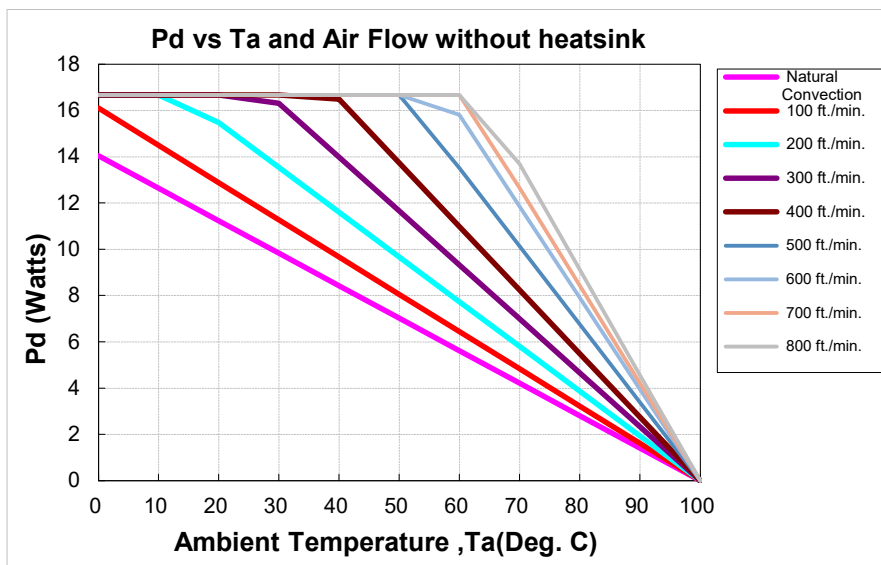

AIR FLOW RATE	TYPICAL $R_{ca}$
Natural Convection	7.12 °C/W
20ft./min. (0.1m/s)	6.21 °C/W
100 ft./min. (0.5m/s)	6.21 °C/W
200 ft./min. (1.0m/s)	5.17 °C/W
300 ft./min. (1.5m/s)	4.29 °C/W
400 ft./min. (2.0m/s)	3.64 °C/W
500 ft./min. (2.5m/s)	2.96 °C/W
600 ft./min. (2.5m/s)	2.53 °C/W
700 ft./min. (2.5m/s)	2.37 °C/W
800 ft./min. (2.5m/s)	2.19 °C/W



# CHB150W12 Series Application Note V10

**Example:**

What is the minimum airflow necessary for a CHB150W12-72S12 operating at nominal line voltage, an output current of 12.5A, and a maximum ambient temperature of 50°C?

**Solution:**

**Given:**  $V_{in}= 72V_{dc}$ ,  $V_o= 12V_{dc}$ ,  $I_o= 12.5A$

**Determine Power dissipation ( $P_d$ ):**  $P_d= P_i-P_o= P_o(1-\eta)/\eta$ ,  $P_d= 12 \times 12.5 \times (1-0.90)/0.90= 16.67Watts$

**Determine airflow:** Given:  $P_d= 16.67W$  and  $T_a= 50^\circ C$

**Check Power Derating curve:** Minimum airflow= 500 ft./min.

**Verify:**

Maximum temperature rise is  $\Delta T= P_d \times R_{ca} = 16.67 \times 2.96= 49.34^\circ C$

Maximum case temperature is  $T_c = T_a + \Delta T= 99.34^\circ C < 100^\circ C$

**Where:**

The  $R_{ca}$  is thermal resistance from case to ambient environment.

$T_a$  is ambient temperature and  $T_c$  is case temperature.

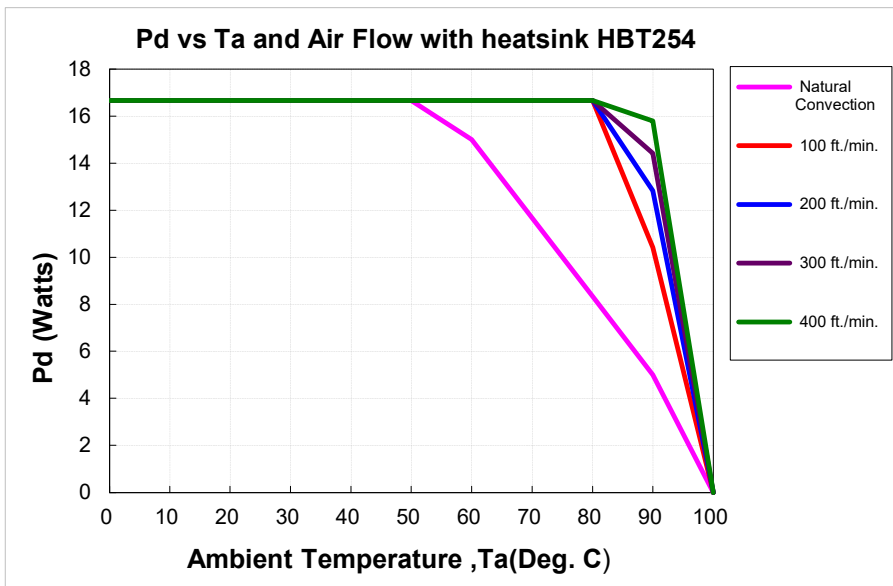

AIR FLOW RATE	TYPICAL $R_{ca}$
Natural Convection 20ft./min. (0.1m/s)	3.00 °C/W
100 ft./min. (0.5m/s)	1.44 °C/W
200 ft./min. (1.0m/s)	1.17 °C/W
300 ft./min. (1.5m/s)	1.04 °C/W
400 ft./min. (2.0m/s)	0.95 °C/W

**Example with heat sink HBT254 (M-C092):**

What is the minimum airflow necessary for a CHB150W12-72S12 operating at nominal line voltage, an output current of 12.5A, and a maximum ambient temperature of 70°C?

**Solution:**

**Given:**  $V_{in}= 72V_{dc}$ ,  $V_o= 12V_{dc}$ ,  $I_o= 12.5A$

**Determine Power dissipation ( $P_d$ ):**  $P_d= P_i-P_o= P_o(1-\eta)/\eta$ ,  $P_d= 12.0 \times 12.5 \times (1-0.90)/0.90= 16.67Watts$

**Determine airflow:** Given:  $P_d= 16.67W$  and  $T_a = 70^\circ C$

**Check above Power de-rating curve:** Minimum airflow= 100 ft./min

**Verify:**

Maximum temperature rise is  $\Delta T= P_d \times R_{ca}= 16.67 \times 1.44= 24.0^\circ C$

Maximum case temperature is  $T_c= T_a + \Delta T= 94.0^\circ C < 100^\circ C$

**Where:**

The  $R_{ca}$  is thermal resistance from case to ambient environment.

$T_a$  is ambient temperature and  $T_c$  is case temperature.



# CHB150W12 Series Application Note V10

## 9.5 Half Brick Heat Sinks:

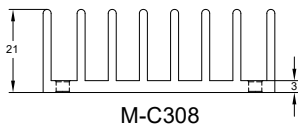
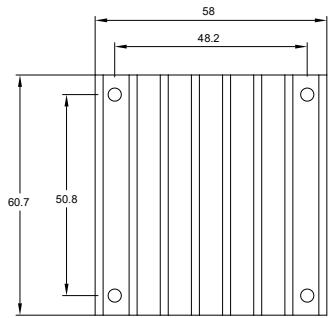

M-C308

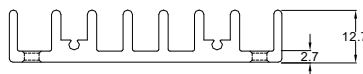
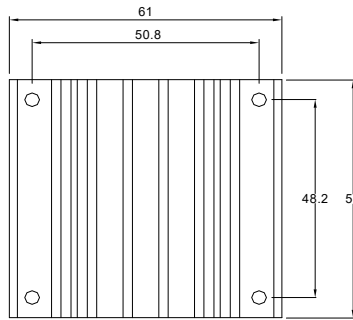

M-C091

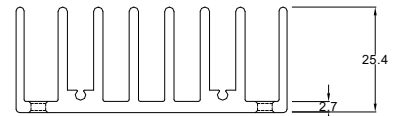
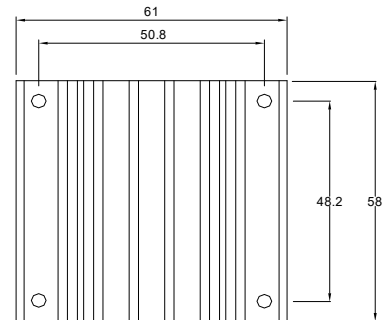

M-C092

All Dimensions in mm

**HBL210 (M-C308) G6620400201**  
Longitudinal Heat Sink

**Rca:**

- 3.90°C/W (typ.), natural convection
- 1.74°C/W (typ.), at 100LFM
- 1.33°C/W (typ.), at 200LFM
- 1.12°C/W (typ.), at 300LFM
- 0.97°C/W (typ.), at 400LFM

**HBT127 (M-C091) G6610120402**  
Transverse Heat Sink

**Rca:**

- 4.70°C/W (typ.), natural convection
- 2.89°C/W (typ.), at 100LFM
- 2.30°C/W (typ.), at 200LFM
- 1.88°C/W (typ.), at 300LFM
- 1.59°C/W (typ.), at 400LFM

**HBT254 (M-C092) G6610130402**  
Transverse Heat Sink

**Rca:**

- 3.00°C/W (typ.), natural convection
- 1.44°C/W (typ.), at 100LFM
- 1.17°C/W (typ.), at 200LFM
- 1.04°C/W (typ.), at 300LFM
- 0.95°C/W (typ.), at 400LFM

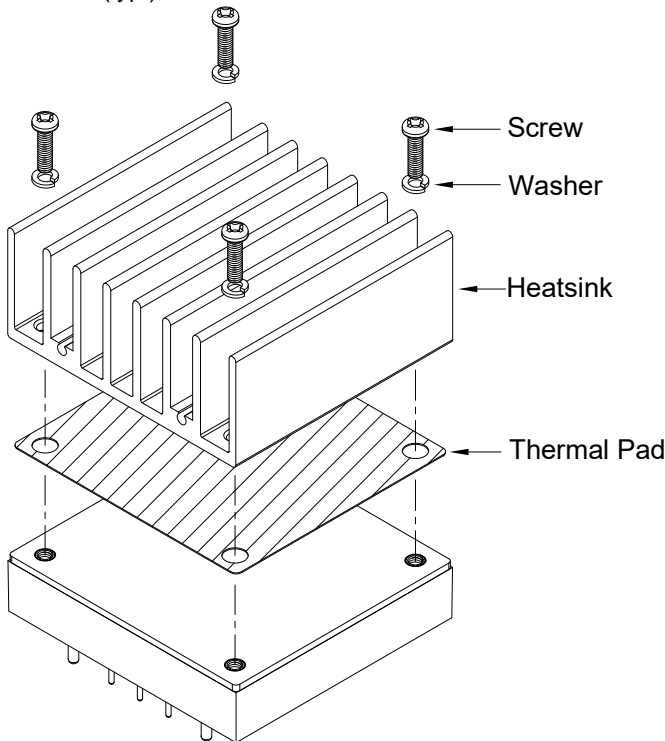

Heatsink: HBL210 (M-C308)

HBT127 (M-C091)

HBT254 (M-C092)

THERMAL PAD PH01: SZ 56.9\*60\*0.25 mm (G6135041091)

Screw & Washer K308W: M3\*8L & WS3.2N (G75A1300322)

Recommended torque 3Kgf-cm



# CHB150W12 Series Application Note V10

## 10. Safety & EMC

### 10.1 Input Fusing and Safety Considerations

The CHB150W12 series converters have no internal fuse. In order to achieve maximum safety and system protection, always use an input line fuse. We recommended a 18A time delay fuse for all models. It is recommended that the circuit have a transient voltage suppressor diode (TVS) across the input terminal to protect the unit against surge or spike voltage and input reverse voltage (as shown).

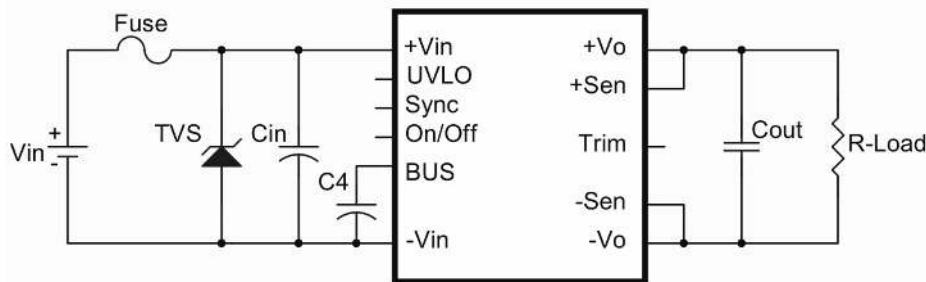

The external input capacitor (Cin) and transient voltage suppressor diode (TVS) are required if CHB150W12 series has to meet EN61000-4-4, EN61000-4-5.

The Cin recommended a 100uF/200V (Nippon Chemi-Con KY series) aluminum capacitor. And the TVS recommended a SMCJ180A transient voltage suppressor.

### 10.2 EMC Considerations

EMI Test standard: EN55032 Class A / EN50121-3-2:2016 Conducted & Radiated Emission

Test Condition: Input Voltage: 110Vdc, Output Load: Full Load

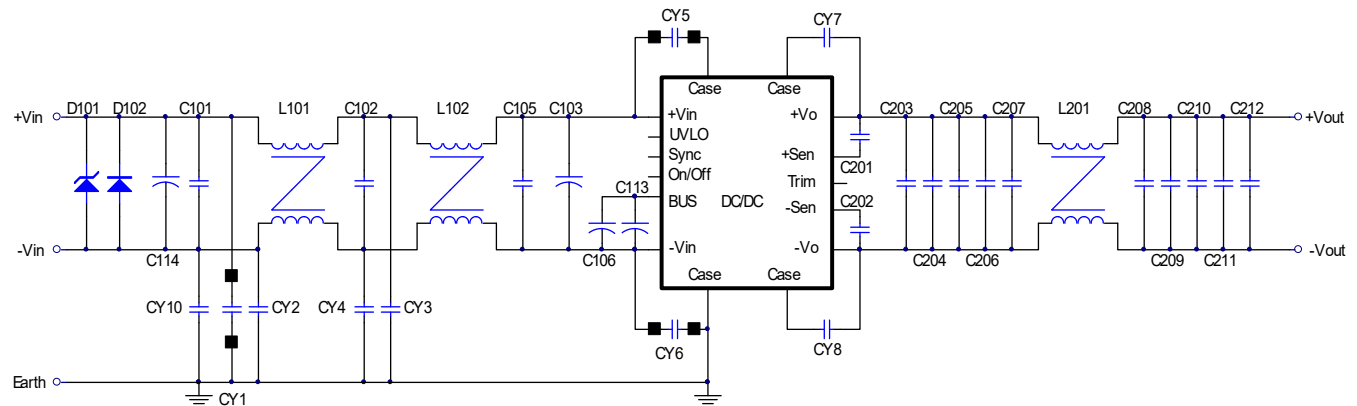

Figure1 Connection circuit



# CHB150W12 Series Application Note V10

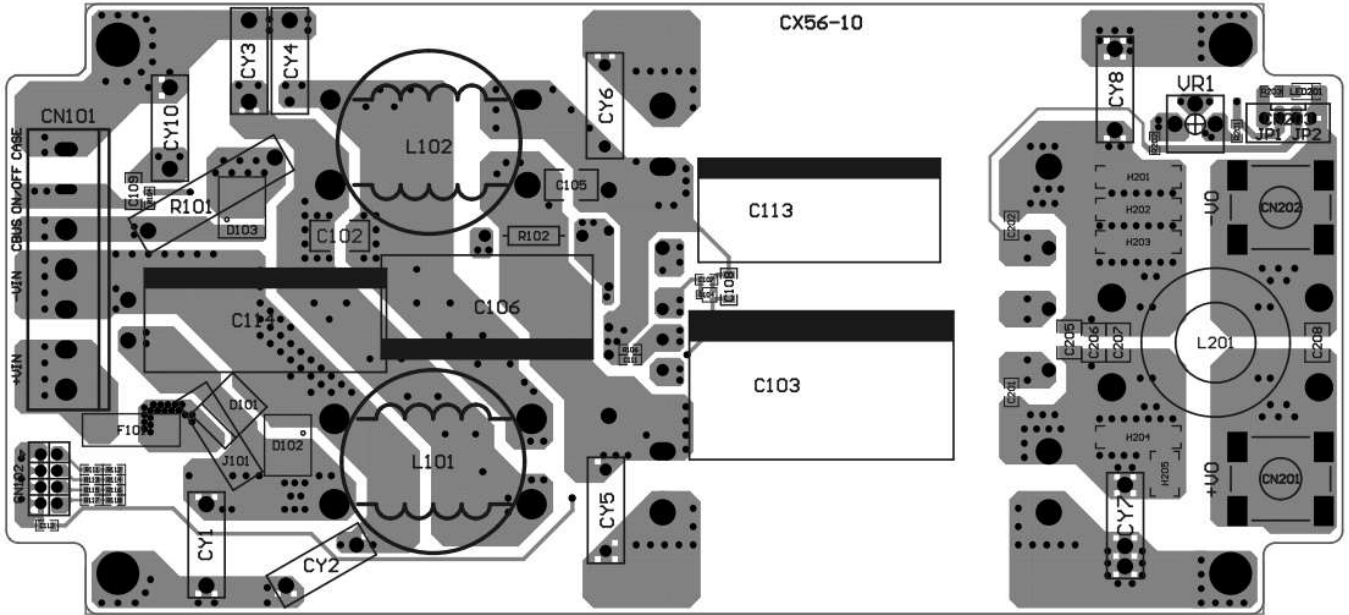

Figure2 PCB layout top view

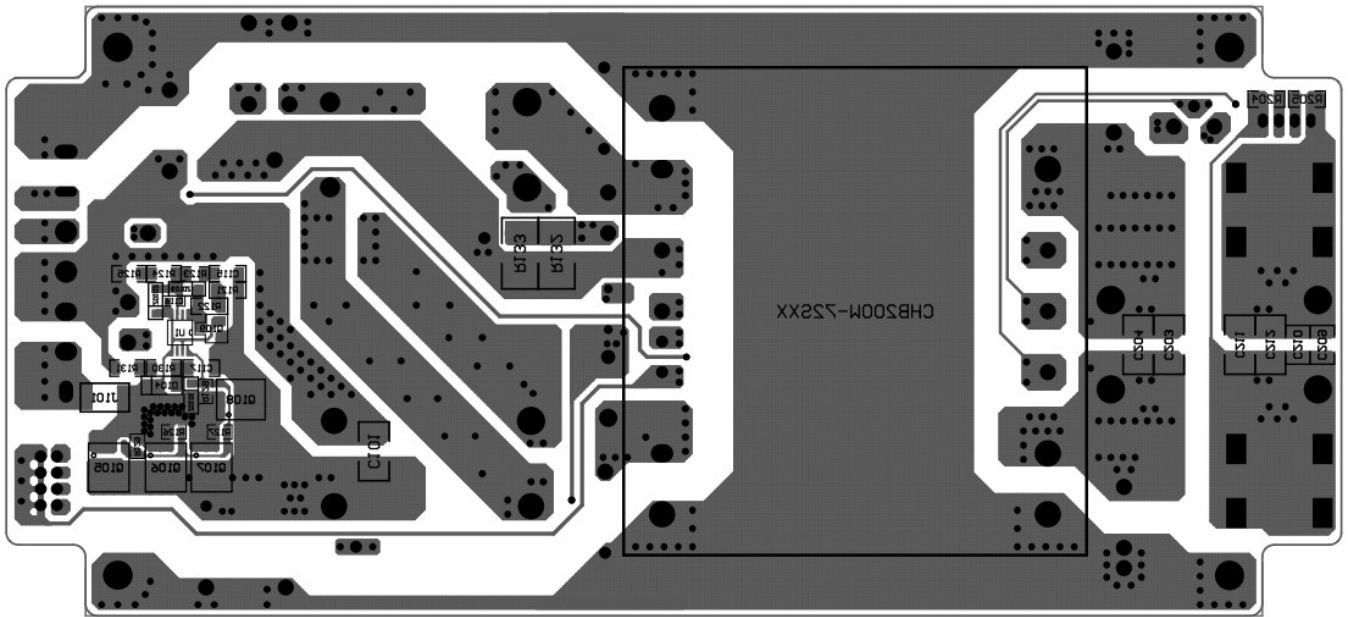

Figure3 PCB layout bottom view



# CHB150W12 Series Application Note V10

## Components value:

	Model Number				
	CHB150W12-72S05	CHB150W12-72S12	CHB150W12-72S15	CHB150W12-72S24	CHB150W12-72S48
C101, C102, C105	1uF/250V SMD				
C103, C113	220uF/200V aluminum cap. KXJ series				
C106	68uF/200V aluminum cap. CS series				
C114	120uF/220V aluminum cap. KXJ series				
C201, C202	0.1uF/100V SMD		0.068uF/50V SMD	0.1uF/100V SMD	
C203~204	6.8uF/50V SMD				2.2uF/100V SMD
C205~C207	10uF/50V SMD				2.2uF/100V SMD
C208	0.1uF/50V SMD				0.1uF/100V SMD
C209~C210	1uF/50V SMD				1uF/100V SMD
C211~C212	6.8uF/50V SMD				2.2uF/100V SMD
CY10	100pF/Y1				
CY1	NC	100pF/Y1		NC	100pF/Y1
CY2	100pF/Y1				
CY3~CY4	2200pF/Y1				
CY5~CY6	2200pF/Y1				
CY7~CY8	0.022uF/275Vac 10mm X2				
L101~L102	0.72mH 0.8mm*2/10T R-22/14/8B MA100-C ALWIN				
L201	0.12mH 0.7mm*8/2T FCN0179C WELL LIGHT		0.51mH 0.8mm*4/4T FCN0179C WELL LIGHT		
BEAD CORE	CY5, CY6, BRI 4*1.5*2 CHILISIN (G4058651007)				

## Note:

- C101, C102, C105: 1812 X7R ceramic
- C103, C113: NIPPON CHEMI-CON KXJ series aluminum capacitor
- C106: Nichicon CS series aluminum capacitor
- C114: NIPPON CHEMI-CON KXJ series aluminum capacitor
- C201, C202: 0805 X7R ceramic
- C203, C204, C211, C212: 1812 X7R ceramic
- C205, C206, C207, C208, C209, C210: 1206 X7R ceramic
- CY1, CY2, CY3, CY4, CY5, CY6, CY10: TDK Y1 capacitor or equivalent
- CY7, CY8: CARLI MPX Series X2 capacitor
- L101, L102: 0.72mH 0.8mm\*2/10T R-22/14/8B MA100-C ALWIN (G91CA125615)
- L201: 0.12mH 0.7mm\*8/2T, FCNO179C WELL LIGHT (G91C7425515)  
0.51mH 0.8mm\*4/4T, FCNO179C WELL LIGHT (G91C7421915)
- D101: SMCJ180A, LITTELFUSE
- D102: STTH8R03DJF-TR ST



# CHB150W12 Series Application Note V10

## Conducted Emission (Input):

CHB150W12-72S05

Line

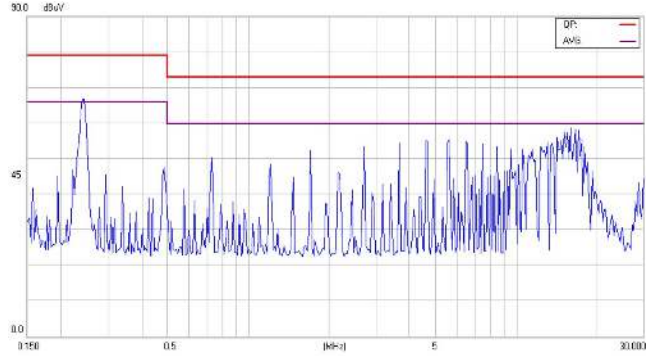

Neutral

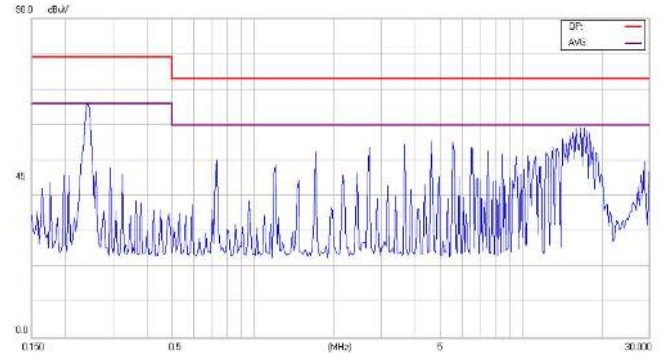

CHB150W12-72S12

Line

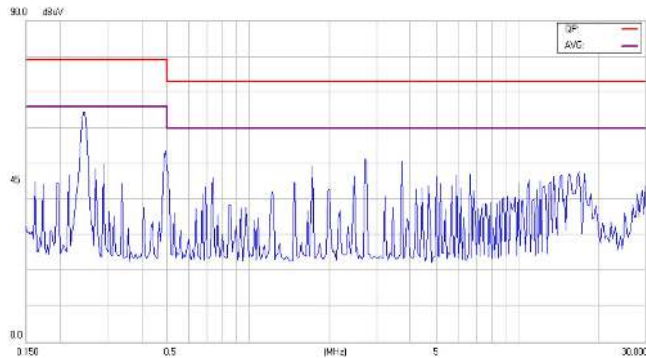

Neutral

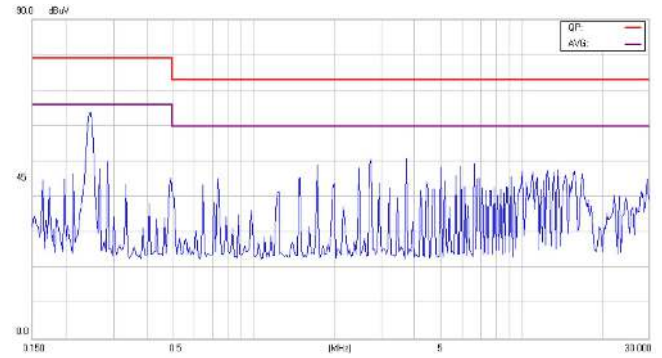

CHB150W12-72S15

Line

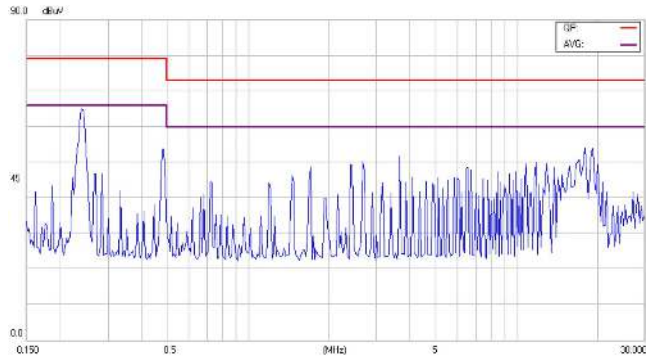

Neutral

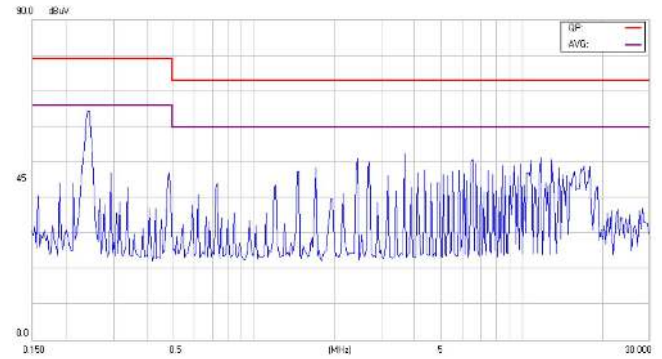

CHB150W12-72S24

Line

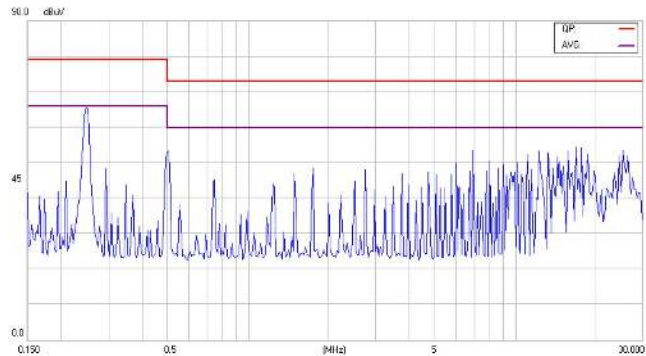

Neutral

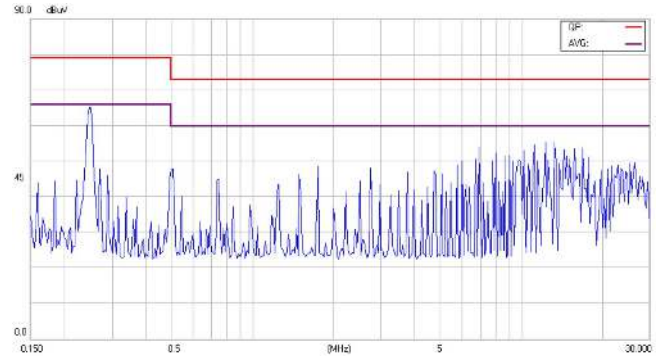



# CHB150W12 Series Application Note V10

## CHB150W12-72S48

Line

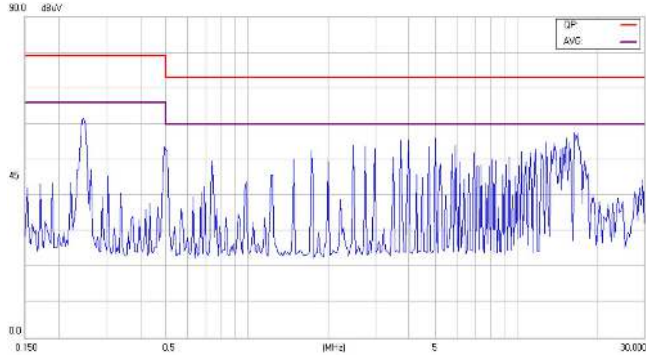

Neutral

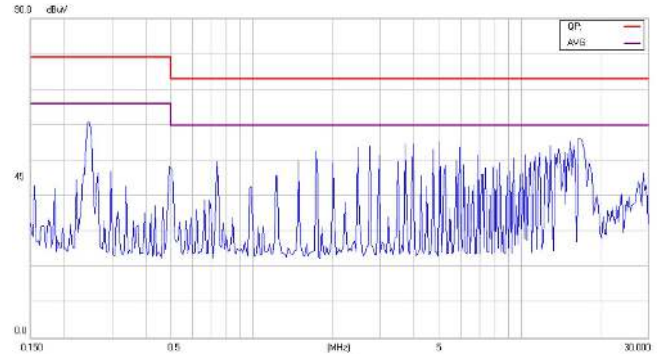

## Conducted Emission (Output):

### CHB150W12-72S05

Positive

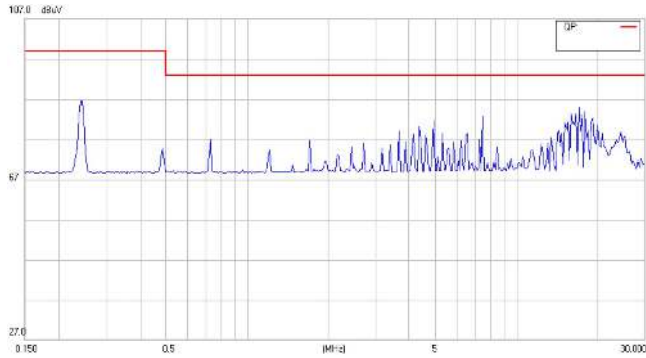

Negative

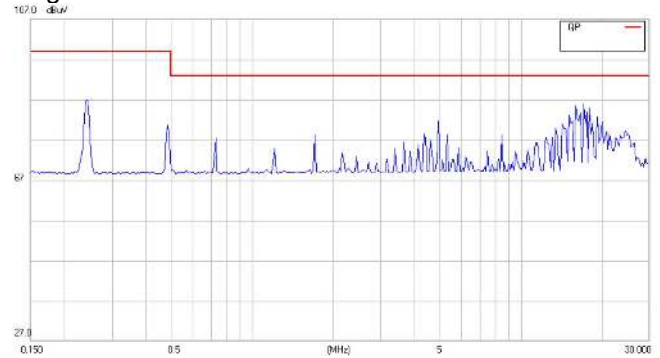

### CHB150W12-72S12

Positive

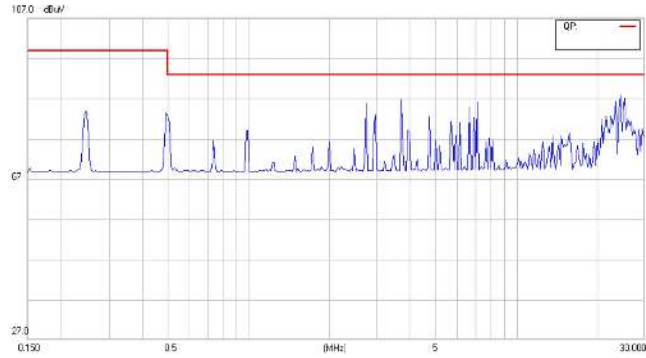

Negative

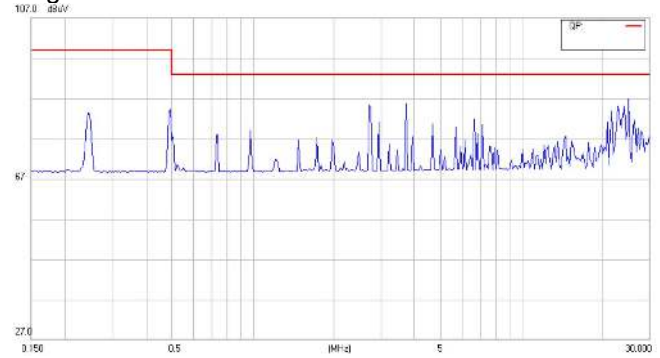

### CHB150W12-72S15

Positive

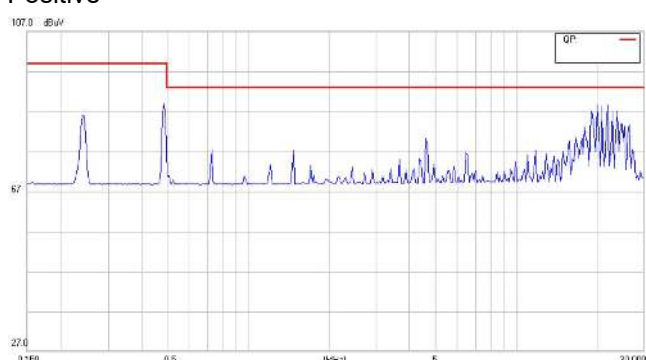

Negative

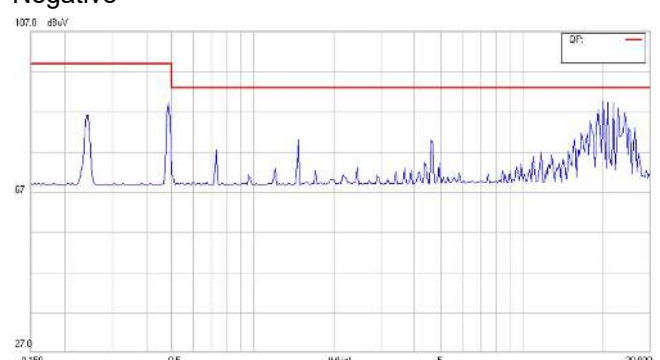



# CHB150W12 Series Application Note V10

CHB150W12-72S24

Positive

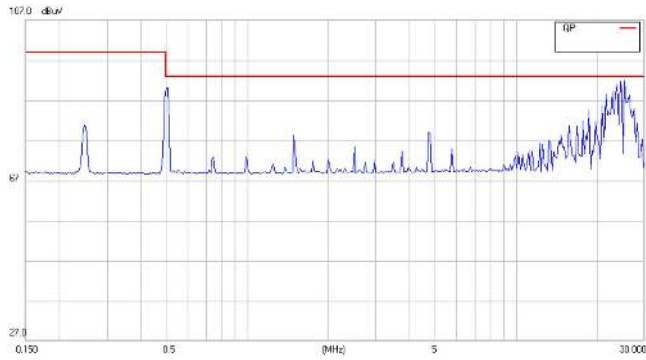

Negative

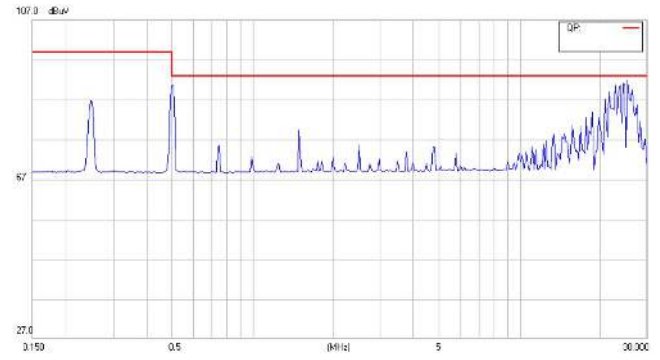

CHB150W12-72S48

Positive

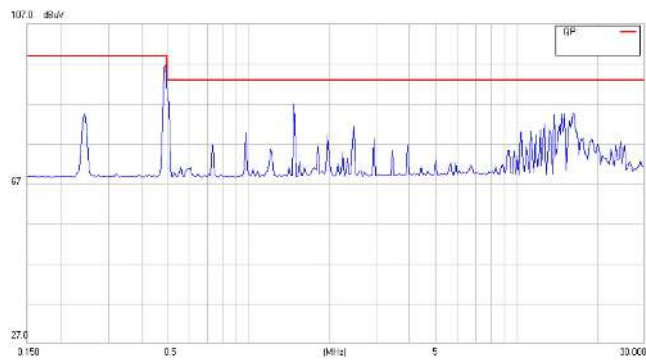

Negative

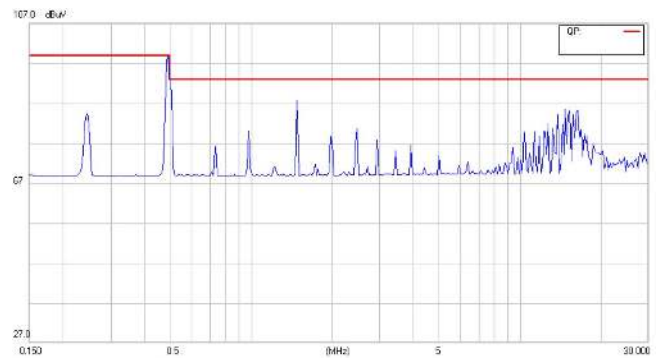

## Radiated Emission:

CHB150W12-72S05

Vertical

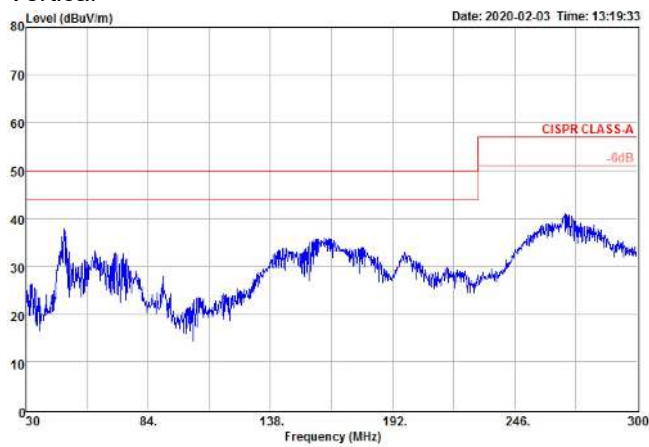

CHB150W12-72S12

Vertical

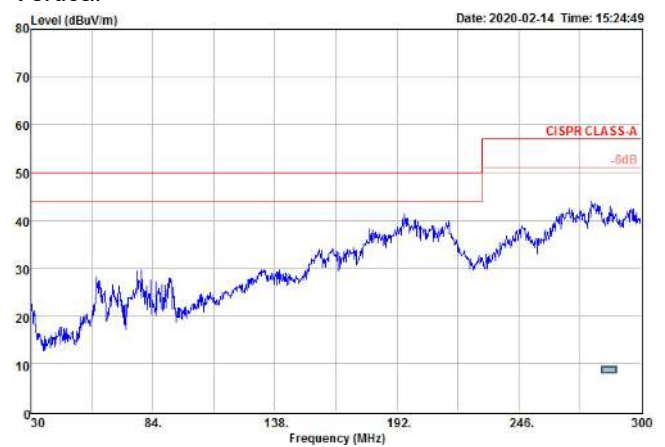



# CHB150W12 Series Application Note V10

CHB150W12-72S15

Vertical

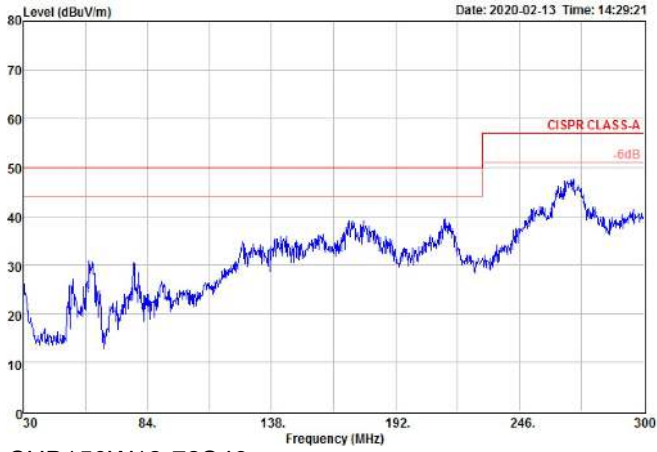

CHB150W12-72S24

Vertical

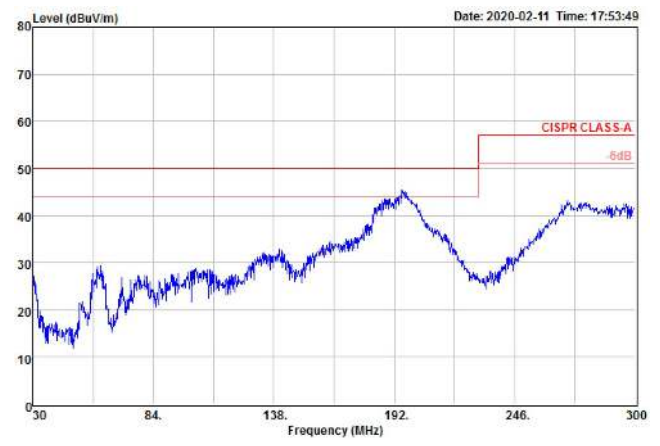

CHB150W12-72S48

Vertical

