



# CFB400W Series Application Note V16 July 2019

## ISOLATED DC-DC CONVERTER CFB400W SERIES APPLICATION NOTE



**Approved By:**

Department	Approved By	Checked By	Written By
Research and Development Department	Enoch	Danny	Joyce
		Jacky	
Quality Assurance Department	Ryan	Benny	



# CFB400W Series

## Application Note V16 July 2019

---

### Contents

1. Introduction .....	3
2. DC-DC Converter Features.....	3
3. Electrical Block Diagram .....	3
4. Technical Specifications.....	5
5. Main Features and Functions.....	9
5.1 Operating Temperature Range.....	9
5.2 Output Voltage Adjustment.....	9
5.3 Over Current Protection.....	9
5.4 Output Overvoltage Protection .....	9
5.5 Remote On/Off.....	9
5.6 UVLO&OVLO (Under/Over Voltage Lock Out).....	9
5.7 Over Temperature Protection .....	9
6. Applications.....	9
6.1 Recommended Layout, PCB Footprint and Soldering Information.....	9
6.2 Convection Requirements for Cooling .....	10
6.3 Thermal Considerations .....	10
6.4 Power De-rating .....	11
6.5 Full Brick Heat Sinks: .....	13
6.6 Efficiency VS. Load .....	15
6.7 Test Set-Up.....	17
6.8 Output Voltage Adjustment.....	17
6.9 Output Remote Sensing .....	19
6.10 Output Ripple and Noise.....	19
6.11 Output Capacitance.....	19
6.12 Parallel Operation.....	19
6.13 IOG Signal.....	20
6.14 Auxiliary Power for Output Signal .....	20
6.15 On/Off Control .....	20
7. Safety & EMC.....	21
7.1 Input Fusing and Safety Considerations.....	21
7.2 EMC Considerations.....	21
8. Part Number .....	24
9. Mechanical Specifications .....	24
9.1 Mechanical Outline Diagrams.....	24



# CFB400W Series

## Application Note V16 July 2019

### 1. Introduction

This specification describes the features and functions of Cincon's CFB400W series of isolated DC-DC Converters. These are highly efficient, reliable and compact, high power density, single output DC/DC converters. The modules can be used in the field of telecommunications, data communications, wireless communications, servers, base station, etc. The CFB400W series can deliver up to 80A output current and provide a precisely regulated output voltage over a wide range of 9-36 and 18-75VDC. The modules can achieve high efficiency up to 90%. The module offers direct cooling of dissipative components for excellent thermal performance. Standard features include isolated remote on/off (positive or negative), remote sense, output voltage adjustment, over voltage, over current and over temperature protection. Parallel operation is also optional.

### 2. DC-DC Converter Features

- 400W Isolated Output
- Efficiency (at full load) up to 90%
- Regulated Output
- Fixed Switching Frequency
- Input Under/Over Voltage Lockout Protection
- Over Current Protection
- Isolated remote On/Off
- Continuous Short Circuit Protection
- Industry Standard Full-Brick Package
- Fully Isolated to 1500VDC

### 3. Electrical Block Diagram

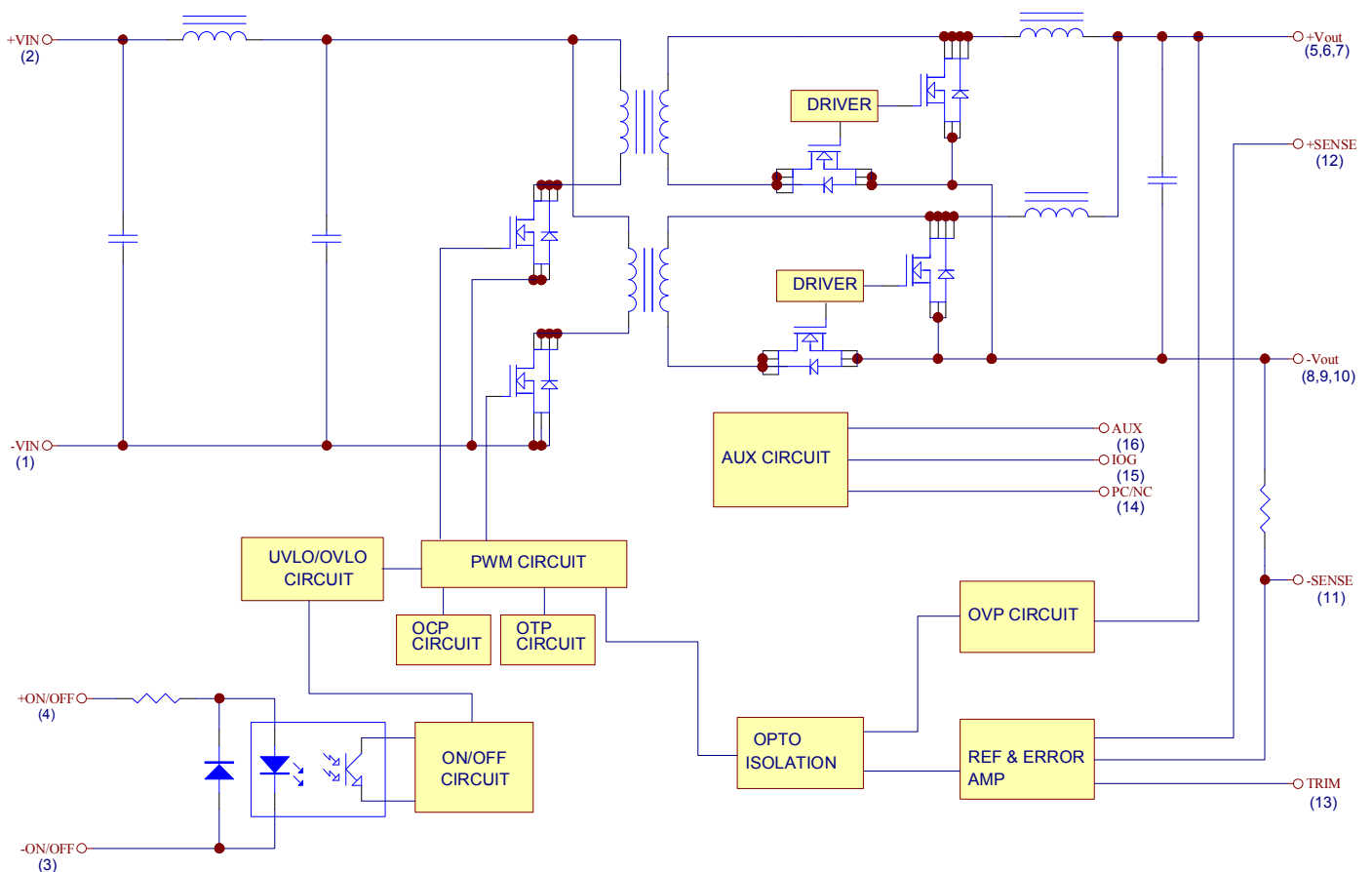

Electrical Block Diagram for 5V Modules



# CFB400W Series Application Note V16 July 2019

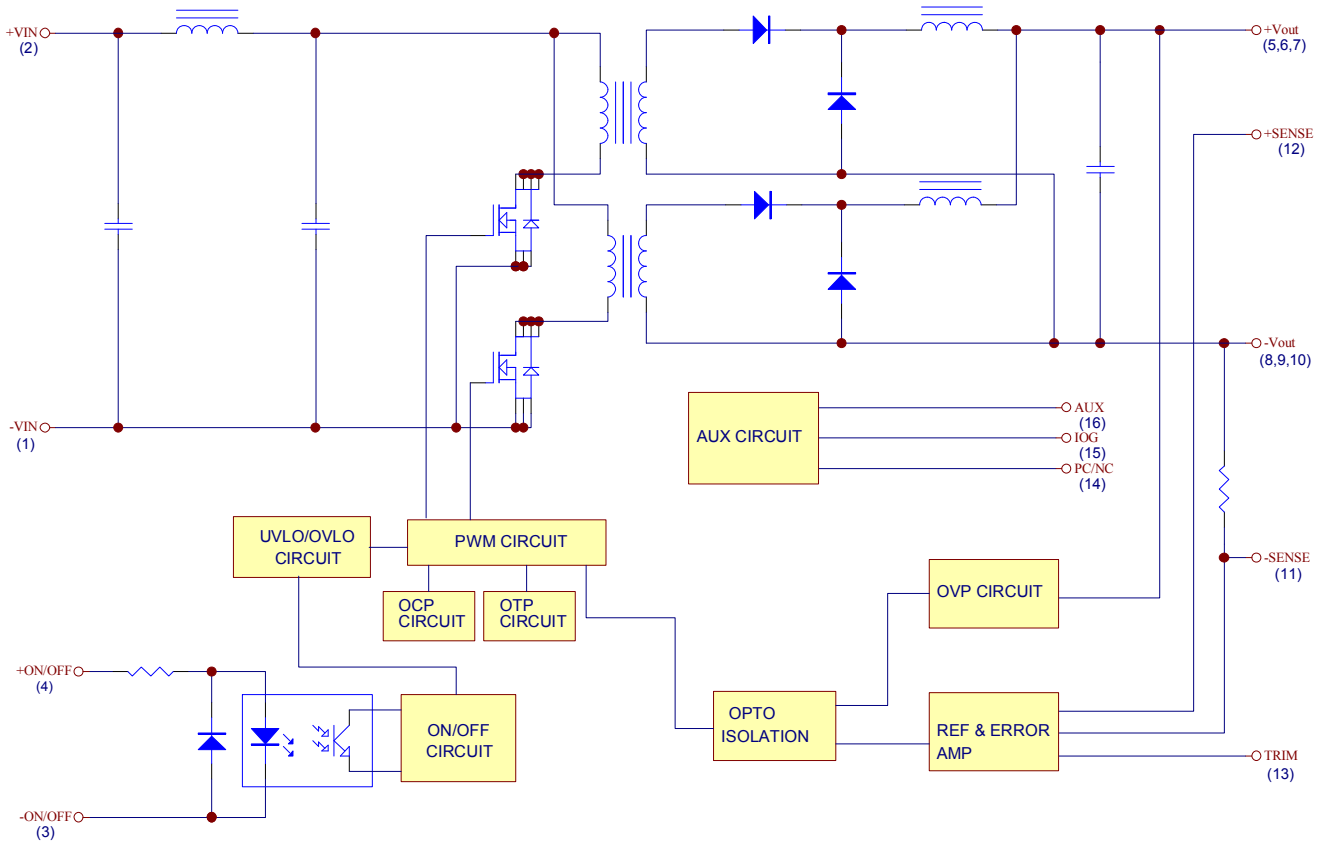

Electrical Block Diagram for other Modules



# CFB400W Series

## Application Note V16 July 2019

### 4. Technical Specifications

(All specifications are typical at nominal input, full load at 25°C unless otherwise noted.)

#### ABSOLUTE MAXIMUM RATINGS

Stresses in excess of the absolute maximum ratings can cause permanent damage to the device. These are absolute stress ratings only, functional operation of the device is not implied at these or any other conditions in excess of those given in the operations sections of the data sheet. Exposure to absolute maximum ratings for extended periods can adversely affect the device reliability.

PARAMETER	NOTES and CONDITIONS	Device	Min.	Typical	Max.	Units
Input Voltage						
Continuous		24SXX	-0.3		36	V <sub>dc</sub>
		48SXX	-0.3		75	
Operating Case Temperature		All	-40		100	°C
Storage Temperature		All	-55		125	°C
Input/Output Isolation Voltage	1 minute	All	1500			V <sub>dc</sub>

#### INPUT CHARACTERISTICS

PARAMETER	NOTES and CONDITIONS	Device	Min.	Typical	Max.	Units
Operating Input Voltage		24SXX	9	24	36	V <sub>dc</sub>
		48SXX	18	48	75	
Input Under Voltage Lockout						
Turn-On Voltage Threshold		24SXX	8	8.5	9	V <sub>dc</sub>
		48SXX	16	17	18	
Turn-Off Voltage Threshold		24SXX	6.5	7.5	8.5	V <sub>dc</sub>
		48SXX	14.5	15.5	16.5	
Lockout Hysteresis Voltage		24SXX		1.0		V <sub>dc</sub>
		48SXX		1.5		
Input Over Voltage Lockout						
Turn-On Voltage Threshold		24SXX	37	40	43	V <sub>dc</sub>
		48SXX	76	80	84	
Turn-Off Voltage Threshold		24SXX	39	42	45	V <sub>dc</sub>
		48SXX	79	83	87	
Lockout Hysteresis Voltage		24SXX		2.0		V <sub>dc</sub>
		48SXX		3.0		
Maximum Input Current	100% Load, V <sub>in</sub> =9V	24SXX		52		A
	100% Load, V <sub>in</sub> =18V	48SXX		26		
Input current at full load	100% Load V <sub>in</sub> =24V	24S05		19.05		A
		24S12		19.36		
		24S24		19.19		
		24S28		19.19		
		24S48		19.19		
	100% Load V <sub>in</sub> =48V	48S05		9.36		A
		48S12		9.41		
		48S24		9.28		
		48S28		9.27		
		48S48		9.27		



# CFB400W Series

## Application Note V16 July 2019

PARAMETER	NOTES and CONDITIONS	Device	Min.	Typical	Max.	Units
No-Load Input Current		24S05		600	1500	mA
		24S12		120	250	
		24S24		120	250	
		24S28		120	250	
		24S48		120	250	
		48S05		300	800	
		48S12		60	150	
		48S24		60	150	
		48S28		60	150	
		48S48		60	150	
Inrush Current ( $I^2t$ )		All			1.0	A <sup>2</sup> s
Input Capacitance (External)	added capacitance, <0.7Ω ESR.	24SXX	1000	3300		uF
		48SXX	330	1000		

### OUTPUT CHARACTERISTICS

PARAMETER	NOTES and CONDITIONS	Device	Min.	Typical	Max.	Units
Output Voltage Set Point	$V_{in}$ =Nominal $V_{in}$ , $I_o = I_{o\_max}$ , $T_c=25^\circ C$	$V_o=5V$	4.95	5.00	5.05	$V_{dc}$
		$V_o=12V$	11.88	12.00	12.12	
		$V_o=24V$	23.76	24.00	24.24	
		$V_o=28V$	27.72	28.00	28.28	
		$V_o=48V$	47.52	48.00	48.48	
Output Voltage Regulation						
Load Regulation	$I_o=I_{o\_min}$ to $I_{o\_max}$	All			±0.5	%
Line Regulation	$V_{in}$ =low line to high line	All			±0.2	%
Temperature Coefficient	$T_c=-40^\circ C$ to $100^\circ C$	All			±0.03	%/°C
Output Voltage Ripple and Noise						
Peak-to-Peak	20MHz bandwidth, Full load, 10uF tantalum and 1.0uF ceramic capacitors (48V: 10uF aluminum and 1.0uF ceramic capacitors)	$V_o=5V$			100	mV
		$V_o=12V$			120	
		$V_o=24V$			240	
		$V_o=28V$			280	
		$V_o=48V$			480	
RMS	20MHz bandwidth, Full load, 10uF solid tantalum and 1.0uF ceramic capacitors (48V: 10uF aluminum and 1.0uF ceramic capacitors)	$V_o=5V$			40	mV
		$V_o=12V$			60	
		$V_o=24V$			100	
		$V_o=28V$			100	
		$V_o=48V$			120	
Operating Output Current Range		$V_o=5V$	0		80	A
		$V_o=12V$	0		33.3	
		$V_o=24V$	0		16.7	
		$V_o=28V$	0		14.3	
		$V_o=48V$	0		8.3	
Output DC Current Limit Inception	Output Voltage=90% Nominal Output Voltage	All	110		150	%



# CFB400W Series

## Application Note V16 July 2019

PARAMETER	NOTES and CONDITIONS	Device	Min.	Typical	Max.	Units
Output Capacitance	Full load (resistive)	Vo=5V	680		10000	uF
		Vo=12V	330		10000	
		Vo=24V	330		4700	
		Vo=28V			2200	
		Vo=48V	100			
Power Good Signal (IOG)	Vout ready: low level, sink current	All			20	mA
	Vout not ready: open drain output, applied voltage	All			50	V

### DYNAMIC CHARACTERISTICS

PARAMETER	NOTES and CONDITIONS	Device	Min.	Typical	Max.	Units
Output Voltage Current Transient						
Step Change in Output Current	d <sub>r</sub> /d <sub>t</sub> =0.1A/us, Load change from 75% to 100% to 75% of I <sub>o,max</sub>	5V		±5	±8	%
		Others		±3	±5	
Setting Time (within 1% Vout nominal)	d <sub>r</sub> /d <sub>t</sub> =0.1A/us	All			500	us
Turn-On Delay and Rise Time						
Turn-On Delay Time, From On/Off Control	V <sub>on/off</sub> to 10%V <sub>o_set</sub>	All			75	ms
Turn-On Delay Time, From Input	V <sub>in_min</sub> to 10%V <sub>o_set</sub>	All			250	ms
Output Voltage Rise Time	10%V <sub>o_set</sub> to 90%V <sub>o_set</sub>	All			50	ms

### EFFICIENCY

PARAMETER	NOTES and CONDITIONS	Device	Min.	Typical	Max.	Units
100% Load		24S05		87.5		%
		24S12		86		
		24S24		87		
		24S28		87		
		24S48		86.5		
		48S05		89		
		48S12		88.5		
		48S24		89		
		48S28		90		
		48S48		89		

### ISOLATION CHARACTERISTICS

PARAMETER	NOTES and CONDITIONS	Device	Min.	Typical	Max.	Units
Isolation Voltage	1 minute; input/output, input/case, output/case input/remote, output/remote	All			1500	V <sub>dc</sub>
Isolation Resistance		All	10			MΩ
Isolation Capacitance		All		4000		pF

### FEATURE CHARACTERISTICS

PARAMETER	NOTES and CONDITIONS	Device	Min.	Typical	Max.	Units
Switching Frequency		All		230		KHz
On/Off Control, Negative Remote On/Off						
Module Off	Floating	All	0		0.01	mA
Module On		All	1.0		10	mA



# CFB400W Series

## Application Note V16 July 2019

PARAMETER	NOTES and CONDITIONS	Device	Min.	Typical	Max.	Units
On/Off Control, Positive Remote On/Off (Models with part number suffix "P")						
Module Off		All	1.0		10	mA
Module On	Floating	All	0		0.01	mA
Auxiliary Output Voltage		AUX	7	10	13	V
Auxiliary Output Current		AUX			20	mA
Load Share Accuracy (50%-100% load)	only for the module (12/24/28/48V) with parallel control function	5V	-	-	-	-
		others	-10		10	%
Off Converter Input Current	Shutdown input idle current	All			50	mA
Output Voltage Trim Range	$V_{in}$ =high line-low line, $P_{out}$ =max rated power, $I_{out}$ =max rated current	Others	-20		+10	%
	$V_{in}$ =9-13V for 24S24, 24S28, 24S48 $V_{in}$ =18-22V for 48S24, 48S28, 48S48 $I_{out}$ =max rated current	$V_o$ =24V $V_o$ =28V $V_o$ =48V	-20		0	
	$V_{in}$ =13-36V, $P_{out}$ =max rated power, $I_{out}$ =max rated current	24S24 24S28 24S48	-20		+10	
	$V_{in}$ =22-75V, $P_{out}$ =max rated power, $I_{out}$ =max rated current	48S24 48S28 48S48	-20		+10	
Output Over Voltage Protection		All	115	125	140	%
Over-Temperature Shutdown		All		110		°C

### GENERAL SPECIFICATIONS

PARAMETER	NOTES and CONDITIONS	Device	Min.	Typical	Max.	Units
MTBF	$I_o=100\%$ of $I_{o\_max}$ ; $T_a=25^\circ\text{C}$ per MIL-HDBK-217F	All		340		K hours
Weight		All		220		grams



# CFB400W Series

## Application Note V16 July 2019

### 5. Main Features and Functions

#### 5.1 Operating Temperature Range

The CFB400W series converters can be operated within a wide case temperature range of  $-40^{\circ}\text{C}$  to  $100^{\circ}\text{C}$ . Consideration must be given to the de-rating curves when ascertaining maximum power that can be drawn from the converter. The maximum power drawn from full brick models is influenced by usual factors, such as:

- Input voltage range
- Output load current
- Forced air or natural convection

#### 5.2 Output Voltage Adjustment

Section 6.8 describes in detail how to trim the output voltage with respect to its set point. The output voltage on all models is adjustable within the range of 80% to 110%.

#### 5.3 Over Current Protection

The converter is protected against over current or short circuit conditions. At the instance of current-limit inception, the module enters a constant current mode of operation. While the fault condition exists, the module will remain in this constant current mode, and can remain in this mode until the fault is cleared. The unit operates normally once the output current is reduced back into its specified range.

#### 5.4 Output Overvoltage Protection

The converter is protected against output over voltage conditions. When the output voltage is higher than the specified range, the module enters a hiccup mode of operation.

#### 5.5 Remote On/Off

The on/off input pins permit the user to turn the power module on or off via a system signal from the primary side or the secondary side. All models are available in "negative logic" (standard) and "positive logic" (optional) versions. Negative logic turns the module on as long as a current (1-10mA) is flowing between +on/off and -on/off and inactive when no current is flowing (floating). Models with part number suffix "P" are the "positive logic" remote on/off version. Positive logic turns the module off as long as a current (1-10mA) is flowing between +on/off and -on/off and active when no current is flowing (floating), the module will turn on.

#### 5.6 UVLO&OVLO (Under/Over Voltage Lock Out)

Input under/over voltage lockout is standard with this converter. At input voltages below/beyond the input under voltage lockout limit, the module operation is disabled.

### 5.7 Over Temperature Protection

These modules have an over temperature protection circuit to safeguard against thermal damage. When the case temperature rises above over temperature shutdown threshold, the converter will shut down to protect it from overheating. The module will automatically restart after it cools down.

### 6. Applications

#### 6.1 Recommended Layout, PCB Footprint and Soldering Information

The system designer or end user must ensure that metal and other components in the vicinity of the converter meet the spacing requirements for which the system is approved. Low resistance and inductance PCB layout traces are the norm and should be used where possible. Due consideration must also be given to proper low impedance tracks between power module, input and output grounds. The recommended soldering profile and PCB layout are shown below.

Lead Free Wave Soldering Profile

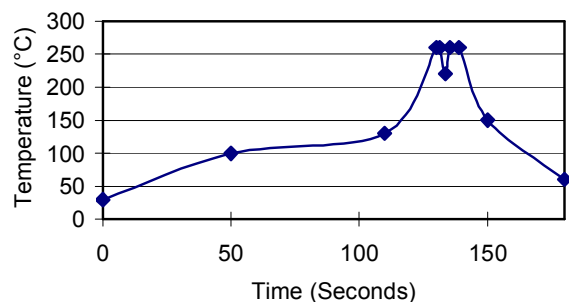

Note :

1. Soldering Materials: Sn/Cu/Ni
2. Ramp up rate during preheat:  $1.4^{\circ}\text{C}/\text{Sec}$  (From  $50^{\circ}\text{C}$  to  $100^{\circ}\text{C}$ )
3. Soaking temperature:  $0.5^{\circ}\text{C}/\text{Sec}$  (From  $100^{\circ}\text{C}$  to  $130^{\circ}\text{C}$ ),  $60\pm 20$  seconds
4. Peak temperature:  $260^{\circ}\text{C}$ , above  $250^{\circ}\text{C}$  3~6 Seconds
5. Ramp up rate during cooling:  $-10.0^{\circ}\text{C}/\text{Sec}$  (From  $260^{\circ}\text{C}$  to  $150^{\circ}\text{C}$ )

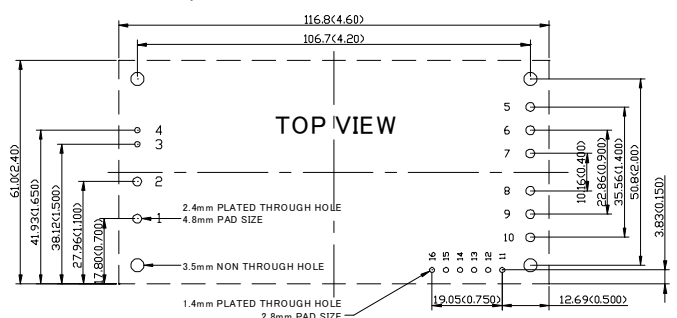

Recommend PCB Pad layout



## CFB400W Series Application Note V16 July 2019

---

### **6.2 Convection Requirements for Cooling**

To predict the approximate cooling needed for the full brick module, refer to the power de-rating curves in section 6.4. These de-rating curves are approximations of the ambient temperatures and airflows required to keep the power module temperature below its maximum rating. Once the module is assembled in the actual system, the module's temperature should be monitored to ensure it does not exceed 100°C as being measured at the center of the top of the case (thus verifying proper cooling).

### **6.3 Thermal Considerations**

The power module operates in a variety of thermal environments; however, sufficient cooling should be provided to help ensure reliable operation of the unit. Heat is removed by conduction, convection, and radiation to the surrounding environment. The test data is presented in section 6.4. The power output of the module should not be allowed to exceed rated power ( $V_{o\_set} \times I_{o\_max}$ ).



# CFB400W Series Application Note V16 July 2019

## 6.4 Power De-rating

The operating case temperature range of CFB400W series is  $-40^{\circ}\text{C}$  to  $+100^{\circ}\text{C}$ . When operating the CFB400W series, proper de-rating or cooling is needed. The maximum case temperature under any operating condition should not be exceeded  $100^{\circ}\text{C}$ .

The following curve is the de-rating curve of CFB400W series without heat sink.

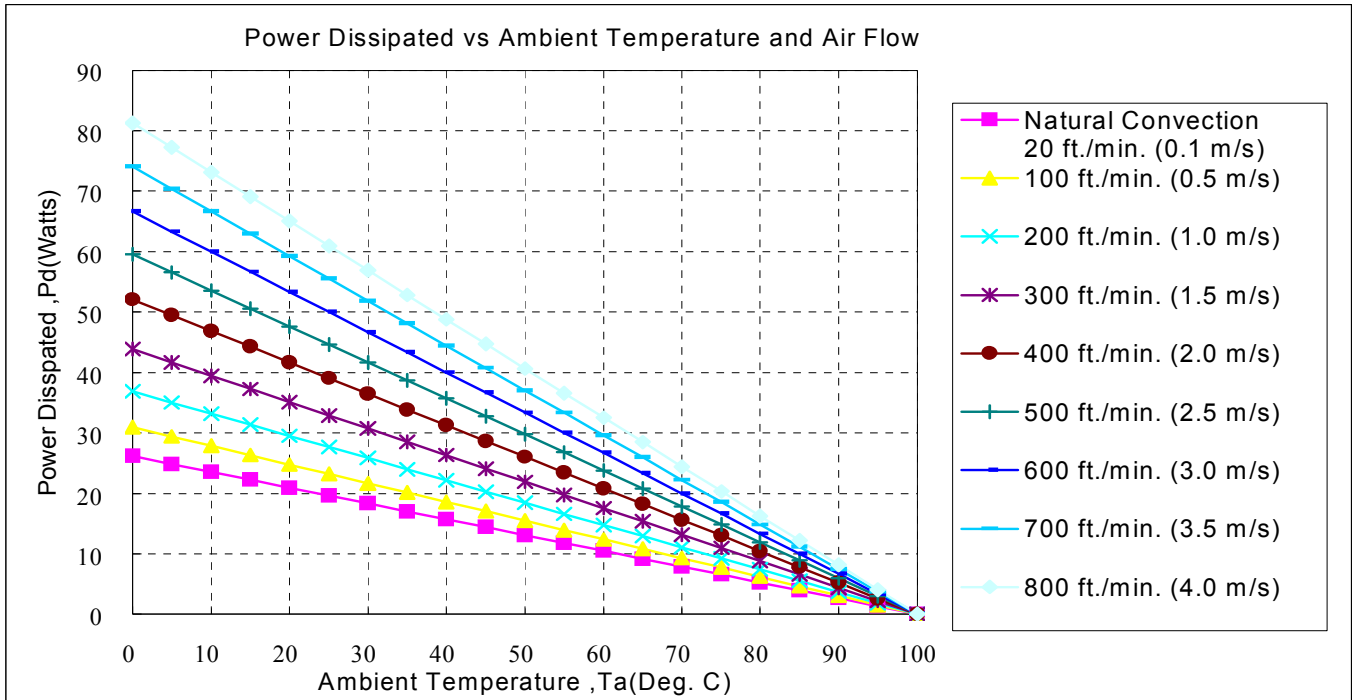

### Example:

What is the minimum airflow necessary for a CFB400W-48S24 operating at nominal line, an output current of 16.7A, and a maximum ambient temperature of  $40^{\circ}\text{C}$

Solution:

Given:  $V_{in}=48V_{dc}$ ,  $V_o=24V_{dc}$ ,  $I_o=16.7A$

Determine Power dissipation ( $P_d$ ):

$$P_d = P_i - P_o = P_o(1-\eta)/\eta$$

$$P_d = 24 \times 16.7 \times (1-0.9)/0.9 = 44.5 \text{ Watts}$$

Determine airflow:

Given:  $P_d = 44.5W$  and  $T_a = 40^{\circ}\text{C}$

Check above Power de-rating curve:

minimum airflow= 700 ft./min.

Verifying: The maximum temperature rise  $\Delta T = P_d \times$

$$R_{ca} = 44.5 \times 1.23 = 54.7^{\circ}\text{C}$$

$$\text{The maximum case temperature } T_c = T_a + \Delta T = 94.7^{\circ}\text{C} < 100^{\circ}\text{C}$$

Where: The  $R_{ca}$  is thermal resistance from case to ambience.

The  $T_a$  is ambient temperature and the  $T_c$  is case temperature.

Chart of Thermal Resistance vs Air Flow

AIR FLOW RATE	TYPICAL $R_{ca}$
Natural Convection 20ft./min. (0.1m/s)	$3.82^{\circ}\text{C/W}$
100 ft./min. (0.5m/s)	$3.23^{\circ}\text{C/W}$
200 ft./min. (1.0m/s)	$2.71^{\circ}\text{C/W}$
300 ft./min. (1.5m/s)	$2.28^{\circ}\text{C/W}$
400 ft./min. (2.0m/s)	$1.92^{\circ}\text{C/W}$
500 ft./min. (2.5m/s)	$1.68^{\circ}\text{C/W}$
600 ft./min. (3.0m/s)	$1.50^{\circ}\text{C/W}$
700 ft./min. (3.5m/s)	$1.35^{\circ}\text{C/W}$
800 ft./min. (4.0m/s)	$1.23^{\circ}\text{C/W}$



# CFB400W Series Application Note V16 July 2019

The following curve is the de-rating curve of CFB400W series with heat sink FBL254 (M-B012).

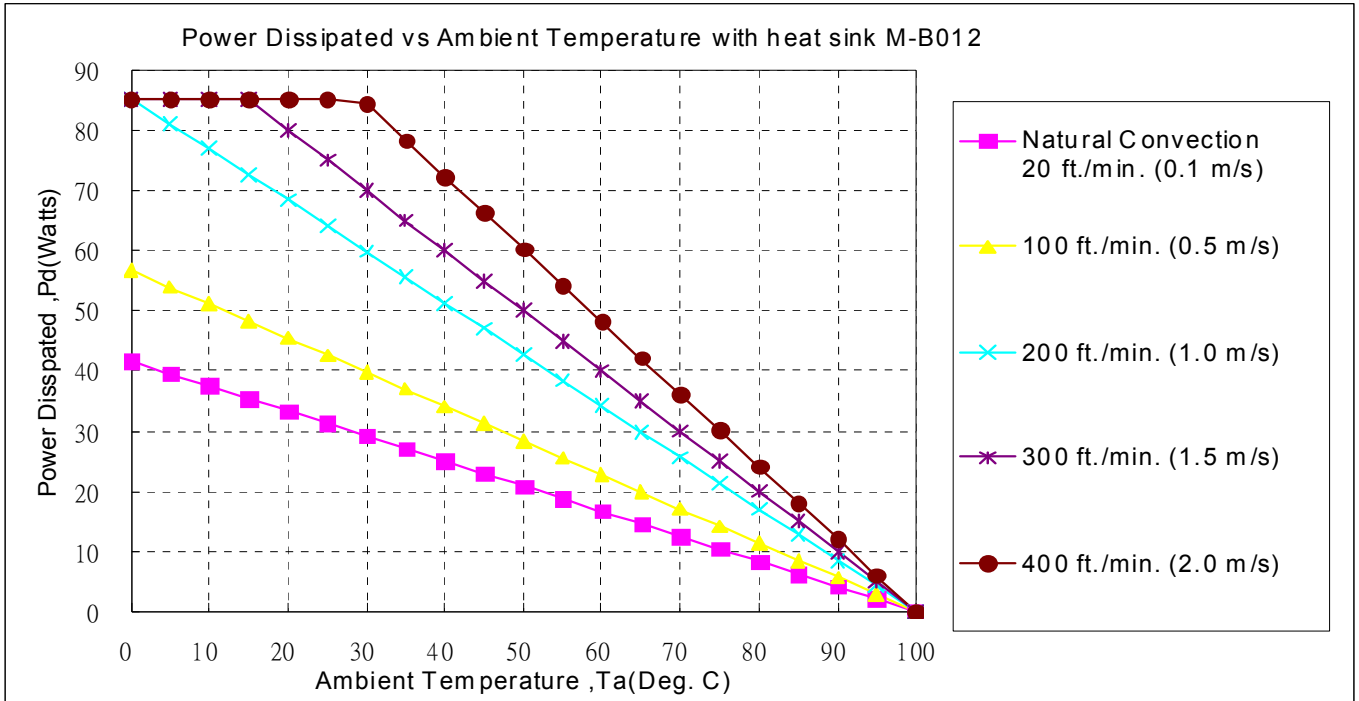

Forced Convection Power De-rating with Heat Sink FBL254 (M-B012)

**Example:**

What is the minimum airflow necessary for a CFB400W-48S24 operating at nominal line, an output current of 16.7A, and a maximum ambient temperature of 40°C

Solution:

Given:  $V_{in}=48V_{dc}$ ,  $V_o=24V_{dc}$ ,  $I_o=16.7A$

Determine Power dissipation ( $P_d$ ):

$$P_d = P_i - P_o = P_o(1-\eta)/\eta$$

$$P_d = 24 \times 16.7 \times (1-0.9)/0.9 = 44.5 \text{ Watts (Chart of Thermal Resistance vs Air Flow)}$$

Determine airflow:

Given:  $P_d=44.5W$  and  $T_a=40^\circ C$

Check above Power de-rating curve:

minimum airflow= 200 ft./min.

Verifying: The maximum temperature rise  $\Delta T = P_d \times R_{ca} = 44.5 \times 1.17 = 52.1^\circ C$

The maximum case temperature  $T_c = T_a + \Delta T = 92.1^\circ C < 100^\circ C$

Where: The  $R_{ca}$  is thermal resistance from case to ambience.

The  $T_a$  is ambient temperature and the  $T_c$  is case temperature.

AIR FLOW RATE	TYPICAL $R_{ca}$
Natural Convection 20ft./min. (0.1m/s)	2.4 °C/W
100 ft./min. (0.5m/s)	1.76 °C/W
200 ft./min. (1.0m/s)	1.17 °C/W
300 ft./min. (1.5m/s)	1.00 °C/W
400 ft./min. (2.0m/s)	0.83 °C/W



# CFB400W Series Application Note V16 July 2019

## 6.5 Full Brick Heat Sinks:

Heat-sink FBL254 (M-B012)

All Dimension In mm

Longitudinal Fins

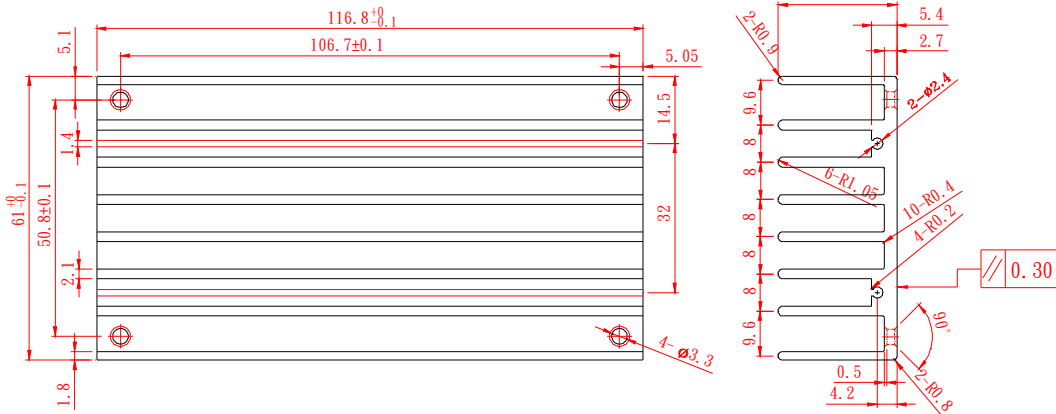

Heat Sink (Clear Mounting Inserts  $\Phi 3.3$ mm Through): 116.8\*61\*25.4 FBL254 (M-B012) G6620090204

Thermal PAD PF01: SR60\*115.8\*0.23 (G6135013070)

Screw & Nut K320N: M3\*20L (G75A1300052) & NH+WOM3\*P0.5N(G75A2440392)

Heat-sink FBL254T (M-C997)

All Dimension In mm

Longitudinal Fins

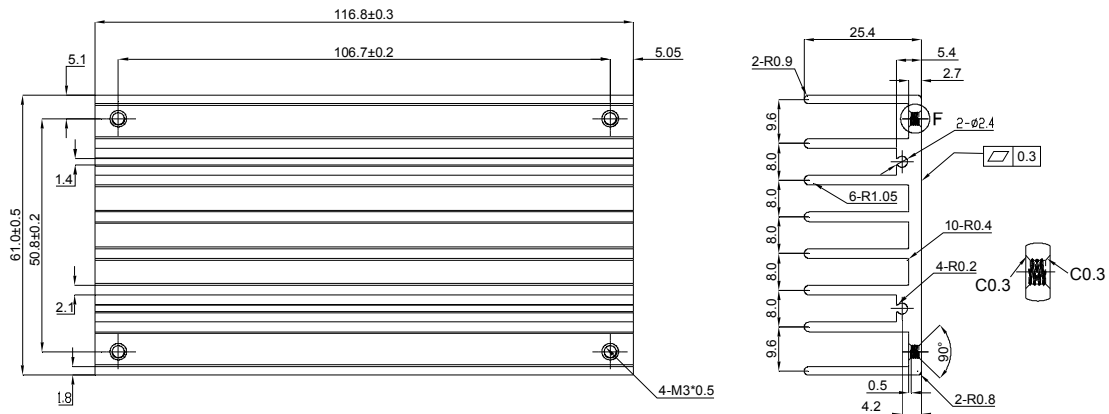

Heat Sink (Mounting Inserts M3\*0.5 Through): 116.8\*61\*25.4 FBL254T (M-C997) G6620980201

Thermal PAD PF01: SR60\*115.8\*0.23 (G6135013070)

Screw & Washer K320W: M3\*20L (G75A1300052) & WS3.2N (G75A47A0752)

AIR FLOW RATE	TYPICAL $R_{ca}$
Natural Convection 20ft./min. (0.1m/s)	2.4 °C/W
100 ft./min. (0.5m/s)	1.76 °C/W
200 ft./min. (1.0m/s)	1.17 °C/W
300 ft./min. (1.5m/s)	1.00 °C/W
400 ft./min. (2.0m/s)	0.83 °C/W



# CFB400W Series Application Note V16 July 2019

## Full Brick Heat Sink Assembly

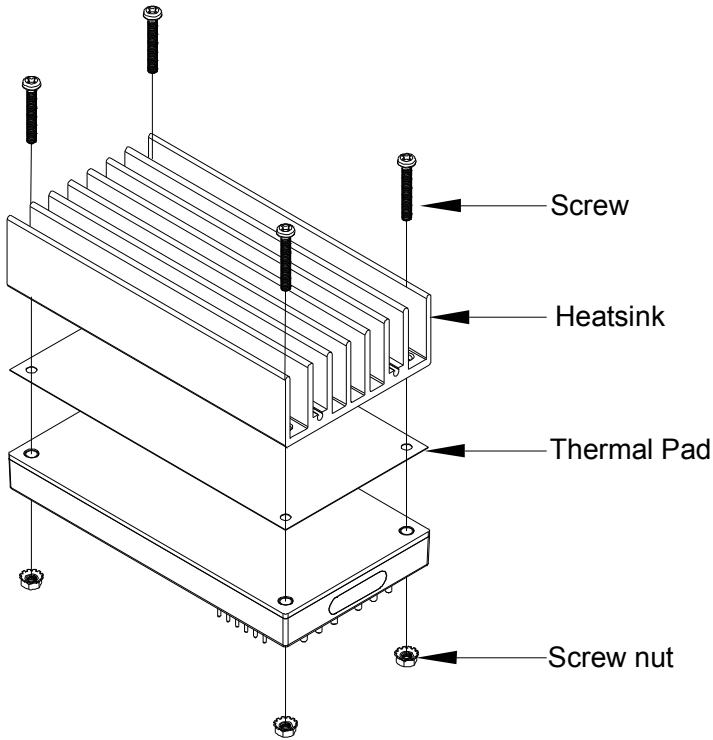

Heat Sink: FBL254 (M-B012)  
 Thermal PAD PF01: SR60\*115.8\*0.23 (G6135013070)  
 Screw & Nut K320N:  
 M3\*20L (G75A1300052) & NNH+WOM3\*P0.5N (G75A2440392)

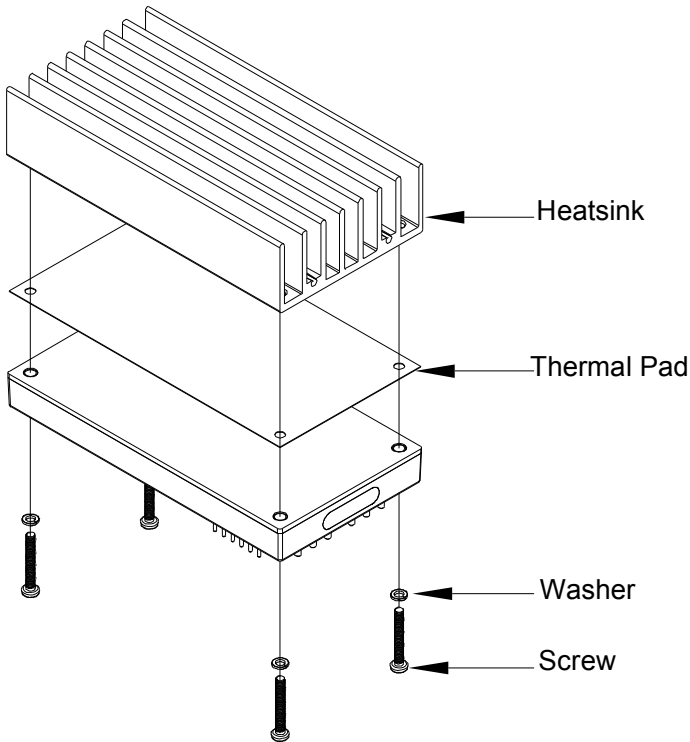

Heat Sink: FBL254T (M-C997)  
 Thermal PAD PF01: SR60\*115.8\*0.23 (G6135013070)  
 Screw & Washer K320W:  
 M3\*20L (G75A1300052) & WS3.2N (G75A47A0752)



# CFB400W Series Application Note V16 July 2019

## 6.6 Efficiency VS. Load

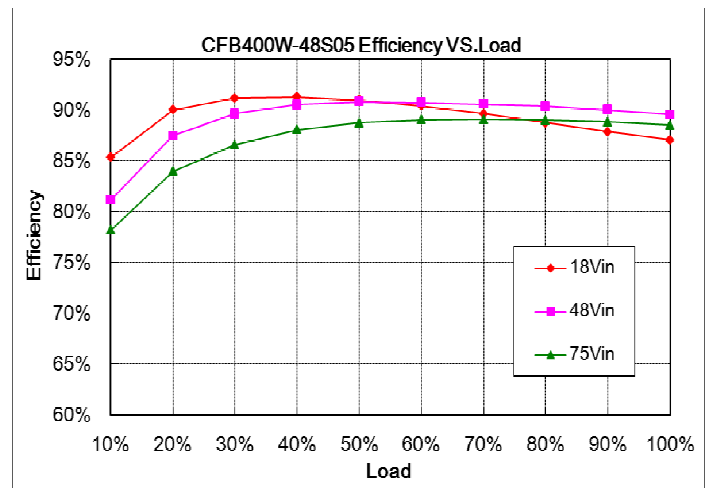
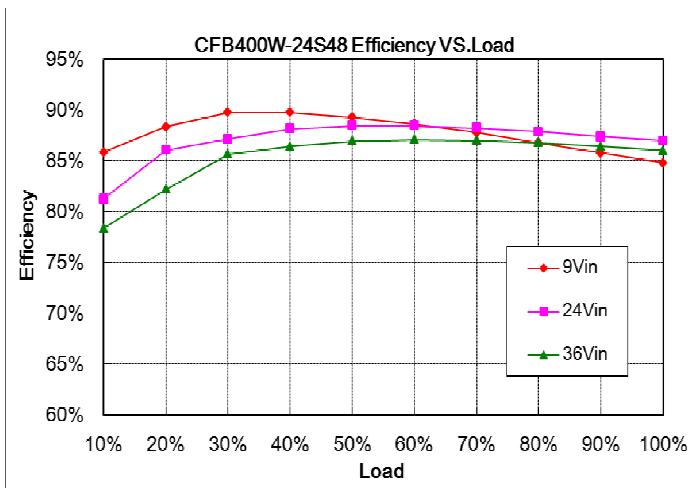
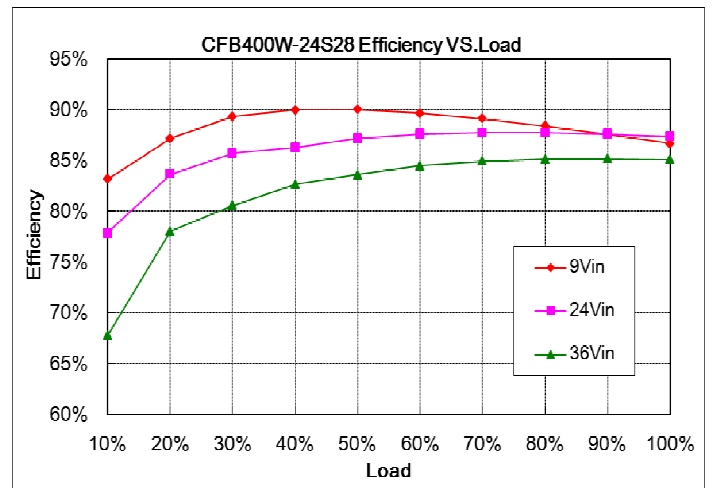
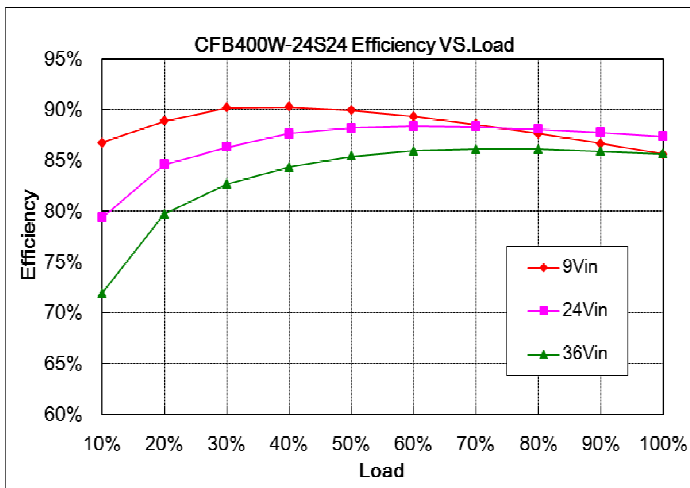
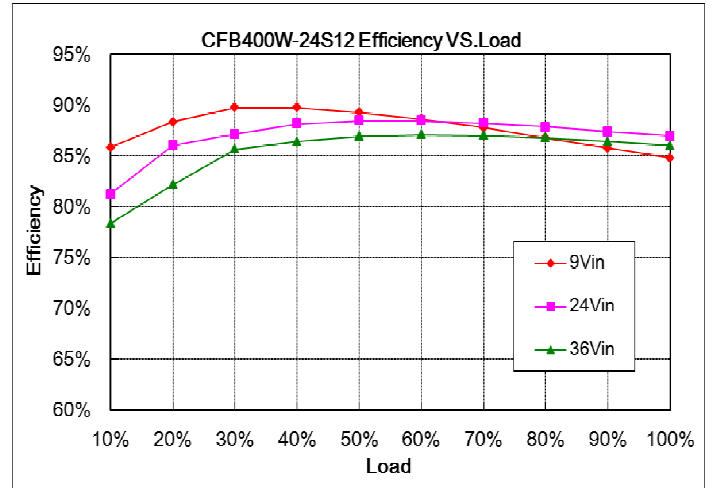
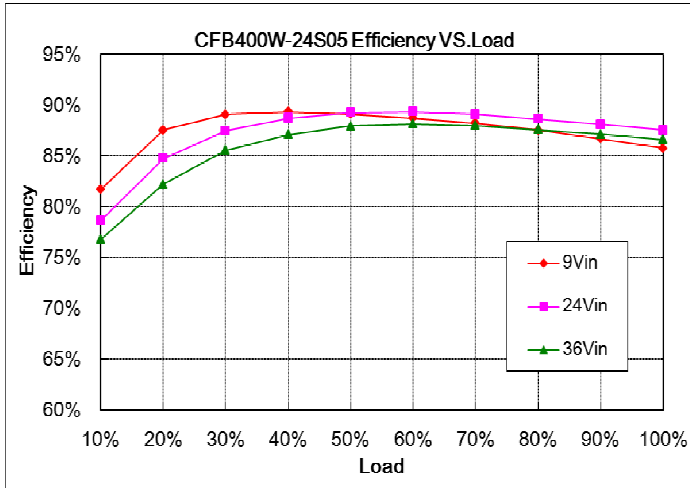



# CFB400W Series

## Application Note V16 July 2019

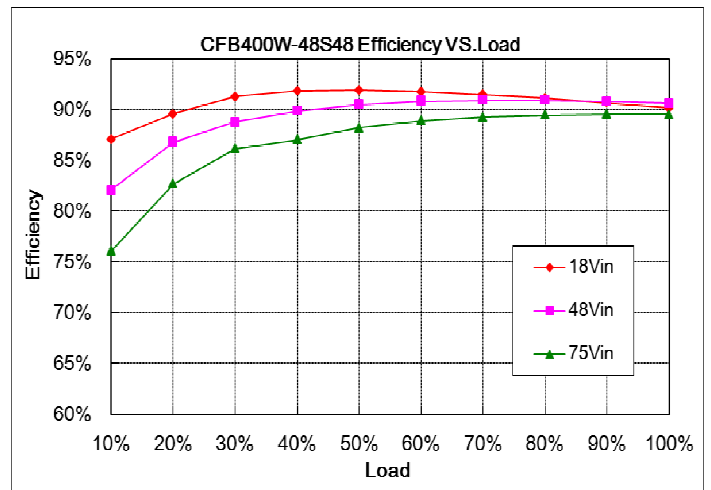
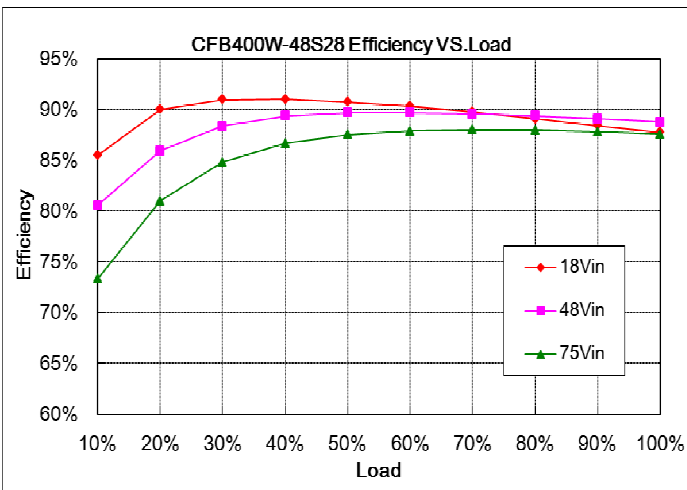
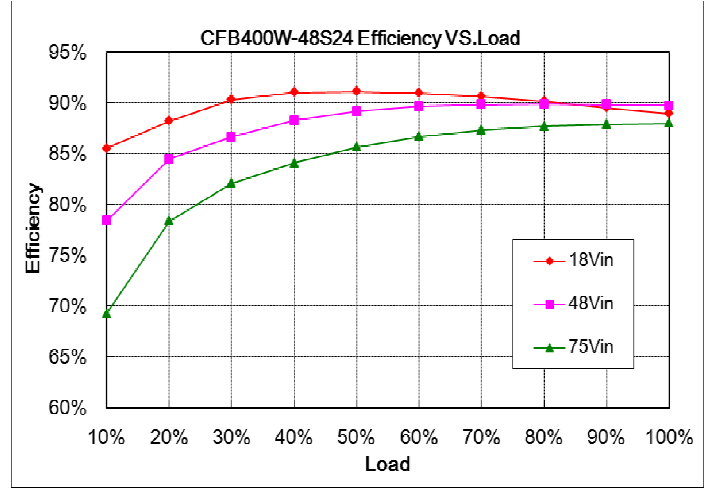
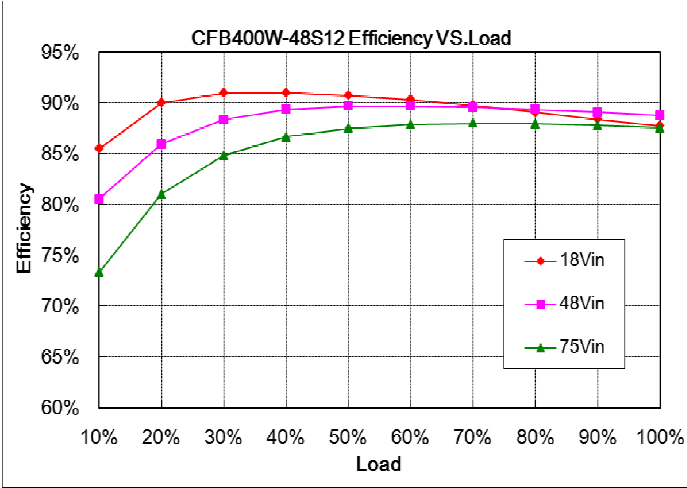



# CFB400W Series

## Application Note V16 July 2019

### 6.7 Test Set-Up

The basic test set-up to measure parameters such as efficiency and load regulation is shown below. When testing the modules under any transient conditions please ensure that the transient response of the source is sufficient to power the equipment under test. We can calculate:

- Efficiency
- Load regulation and line regulation.

The value of efficiency is defined as:

$$\eta = \frac{V_o \times I_o}{V_{in} \times I_{in}} \times 100\%$$

Where:

$V_o$  is output voltage,  
 $I_o$  is output current,  
 $V_{in}$  is input voltage,  
 $I_{in}$  is input current.

The value of load regulation is defined as:

$$Load.reg = \frac{V_{FL} - V_{NL}}{V_{NL}} \times 100\%$$

Where:

$V_{FL}$  is the output voltage at full load  
 $V_{NL}$  is the output voltage at no load

The value of line regulation is defined as:

$$Line.reg = \frac{V_{HL} - V_{LL}}{V_{LL}} \times 100\%$$

Where:  $V_{HL}$  is the output voltage of maximum input voltage at full load.  $V_{LL}$  is the output voltage of minimum input voltage at full load.

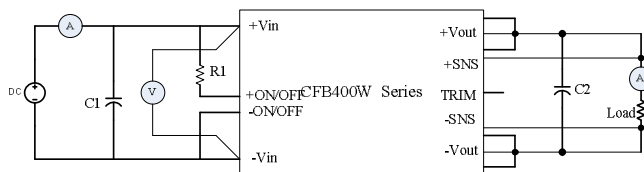

CFB400W Series Test Setup

### Recommend C1 and C2 Value

CFB400W-24SXX: C1:1000uF/50V  
 CFB400W-48SXX: C1:330uF/100V

For CFB400W series it's necessary to connect the input electrolytic capacitor C1 with low ESR to prevent the effective of input line inductance to the DC/DC converter.

For stable operation, connect a low impedance electrolytic capacitor C2 in the output terminals according to output capacitance items in **page 7**. When operated at lower temperature than  $-20^\circ\text{C}$ ,

increasing the C2 capacitance with three or four times more than the recommended value.

### 6.8 Output Voltage Adjustment

The Trim input permits the user to adjust the output voltage up or down according to the trim range specification (80% to 110% of nominal output). This is accomplished by connecting an external resistor between the +Vout and +Sense pin for trim up and between the TRIM and -Sense pin for trim down, see Figure

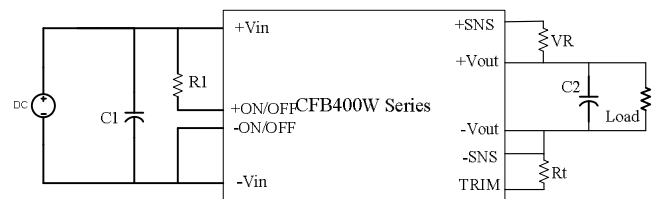

Output voltage trim circuit configuration

The Trim pin should be left open if trimming is not being used. The output voltage can be determined by the following equations:

$$V_f = \frac{1.24 \times \left( \frac{R_t \times 33}{R_t + 33} \right)}{7.68 + \frac{R_t \times 33}{R_t + 33}}$$

$$V_{out} = (V_o + V_R) \times V_f$$

Unit: K $\Omega$

$V_o$ : Nominal Output Voltage

Recommend  $R_t$ : 6.8K $\Omega$

The output voltage can also be adjustment by using external DC voltage

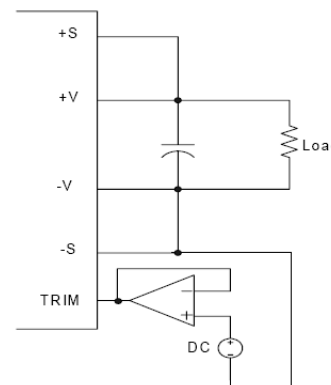

$$\text{Output Voltage} = \text{TRIM Terminal Voltage} \times \text{Nominal Output Voltage}$$

Note: the output voltage can be increased by the remote sense and the trim. The amount of power delivered by the module is defined as the voltage at the output terminals multiplied by the output current. When using remote sense and trim, the output voltage



# CFB400W Series

## Application Note V16 July 2019

of the module can be increased and consequently increase the power output of the module if output current remains unchanged. Care should be taken to ensure that the maximum output power of the module remains at or below the maximum rated power (Maximum rated power =  $V_{o,set} \times I_{o,max}$ )  
 The output voltage on 5V&12V models is adjustable within the range of +10% to -20%. For 24V&28V&48V models, see input& output trim curves for trim up and trim down ranges.

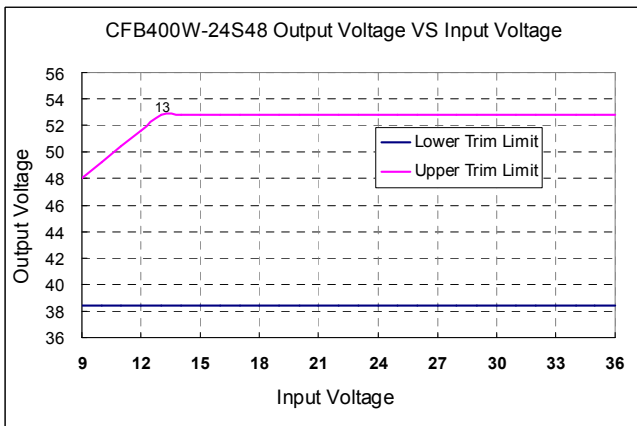
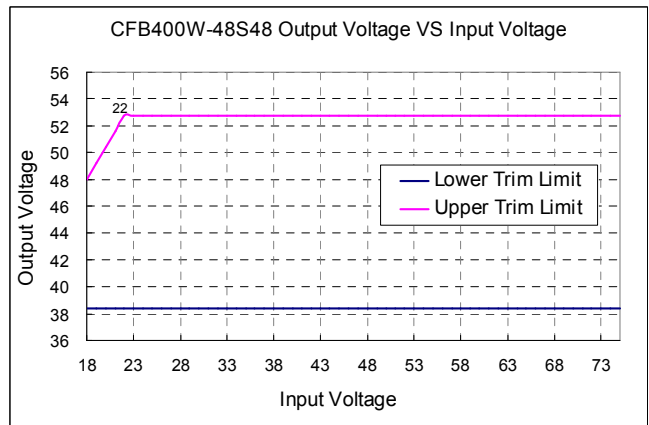
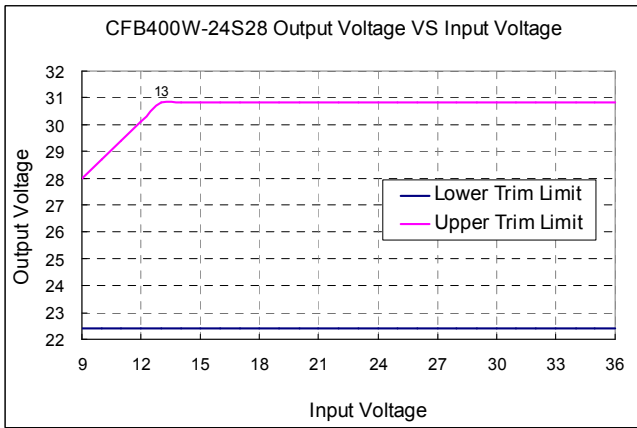
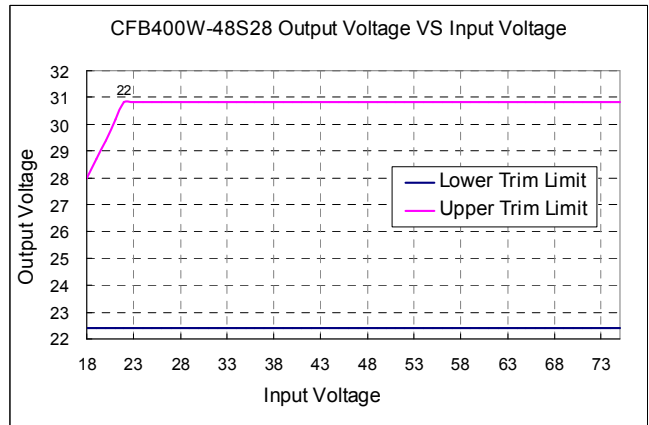
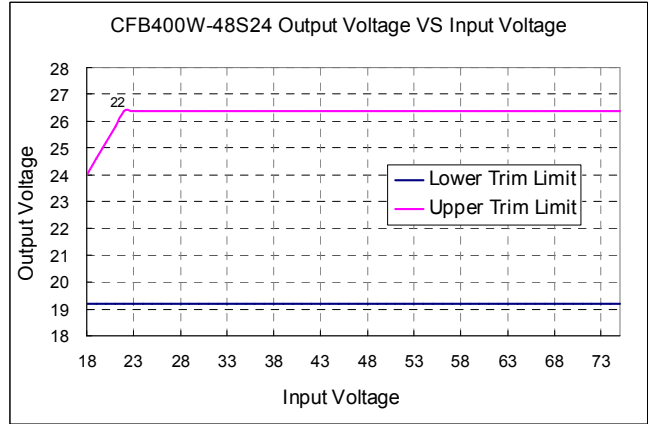
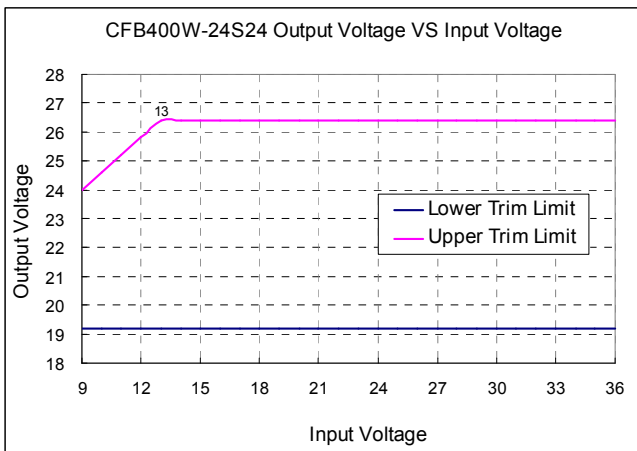



# CFB400W Series

## Application Note V16 July 2019

### 6.9 Output Remote Sensing

The CFB400W SERIES converter has the capability to remotely sense both lines of its output. This feature moves the effective output voltage regulation point from the output of the unit to the point of connection of the remote sense pins. This feature automatically adjusts the real output voltage of the CFB400W series in order to compensate for voltage drops in distribution and maintain a regulated voltage at the point of load. The remote-sense voltage range is:

$$[(+V_{out}) - (-V_{out})] - [(+Sense) - (-Sense)] \leq 10\% \text{ of } V_{o\_nominal}$$

If the remote sense feature is not to be used, the sense pins should be connected locally. The +Sense pin should be connected to the +Vout pin at the module and the -Sense pin should be connected to the -Vout pin at the module.

This is shown in the schematic below.

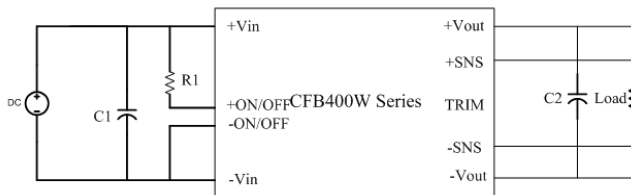

Note:

Although the output voltage can be increased by both the remote sense and by the trim, the maximum increase for the output voltage is not the sum of both. The maximum increase is the larger of either the remote sense or the trim. The amount of power delivered by the module is defined as the voltage at the output terminals multiplied by the output current. When using remote sense and trim, the output voltage of the module can be increased and consequently increase the power output of the module if output current remains unchanged. Care should be taken to ensure that the maximum output power of the module remains at or below the maximum rated power (Maximum rated power =  $V_{o,set} \times I_{o,max}$ )

### 6.10 Output Ripple and Noise

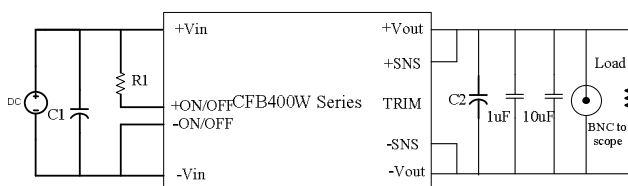

Output ripple and noise is measured with 1.0uF ceramic and 10uF solid tantalum capacitors across the output.

### 6.11 Output Capacitance

The CFB400W series converters provide unconditional stability with or without external capacitors. For good transient response, low ESR output capacitors should be located close to the point of load. PCB design emphasizes low resistance and inductance tracks in consideration of high current applications. Output capacitors with their associated ESR values have an impact on loop stability and bandwidth. The output capacitance is recommended in output capacitance items which need three or four times capacitance when operating below  $-20^{\circ}\text{C}$  and the absolute maximum value of CFB400W series' output capacitance is 10000uF. For values larger than this, please contact your local CINCON's representative.

### 6.12 Parallel Operation

The CFB400W series (except 5Vout) are also designed for parallel operation. When paralleled, the load current can be equally shared between the modules by connecting the PC pins together.

There are two different parallel operations for CFB400W series, one is parallel operation when load can't be supplied by only one power unit; the other is the N+1 redundant operation which is high reliable for load of N units by using N+1 units.

(a) parallel operation (except 5Vout)

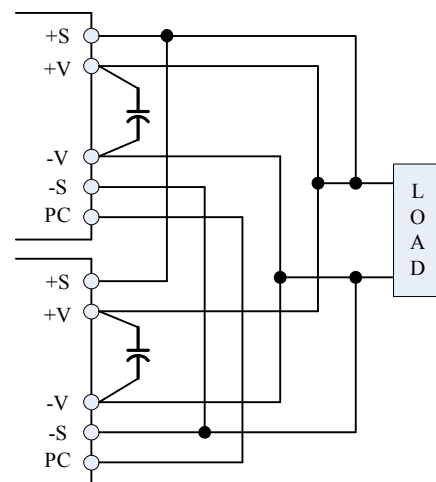

(b) Parallel operation with programmed and adjustable output (except 5Vout)



# CFB400W Series

## Application Note V16 July 2019

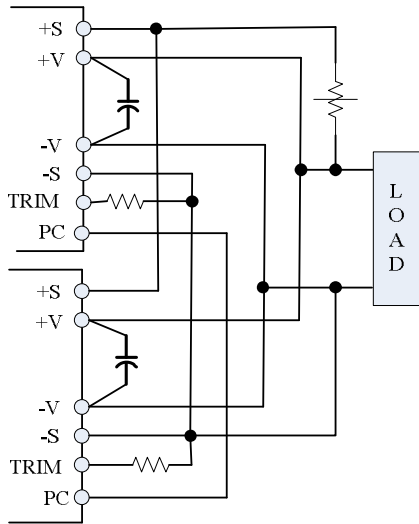

(c) N+1 redundant connection

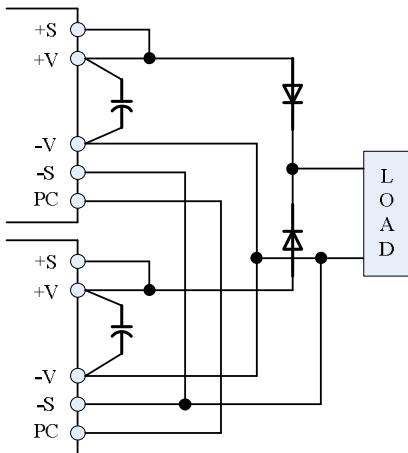

(d) N+1 redundant connection with programmed output and adjustable output voltage

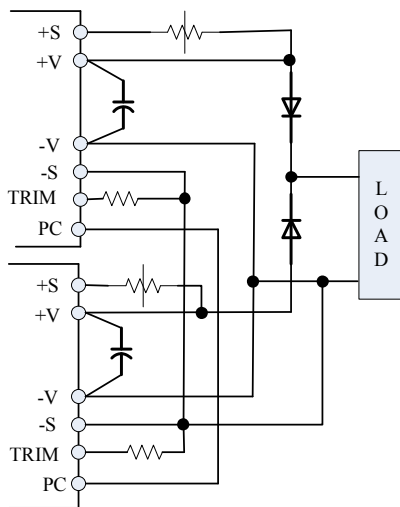

### 6.13 IOG Signal

Normal and abnormal operation of the converter can be monitored by using the I.O.G signal. Output of this signal monitor is located at the secondary side and is

open collector output, you can use the signal by the internal aux power supply or the the external DC supply as the following figures. the ground reference is the  $-sense$ . For the sink current and voltage rating applied see output characteristic on **page 7**.

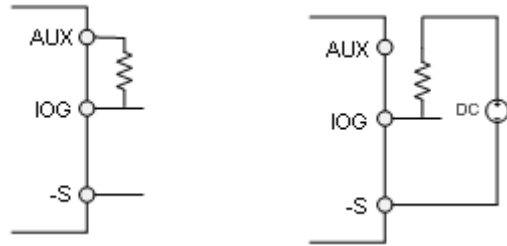

By internal AUX

By external DC supply

This signal is low when the converter is normally operating and high when the converter is disabled or when the converter is abnormally operating.

### 6.14 Auxiliary Power for Output Signal

The auxiliary power supply output is within 7-13V with maximum current of 20mA. Ground reference is the  $-sense$  Pin.

### 6.15 On/Off Control

The converter's on/off can be controlled from the input side or the output side.

Output voltage turns on when current is made to through on/off terminals which can be reached by opening or closing the switches. The maximum current through the on/off pin is 10mA, setting the resistor value to avoid the maximum current through the ON/OFF pins.

(A) Controlling the on/off terminal from the input side, recommend R1 value is 12K (1.0W) for 48V<sub>in</sub> and 6K (0.5W) for 24V<sub>in</sub>.

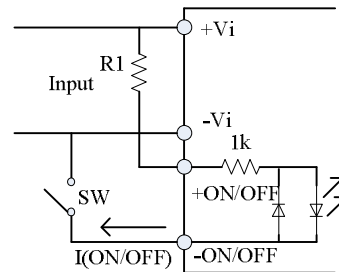

(B) Controlling the on/off terminal from the output side, Recommend R2 value is 4.3K (0.1W).

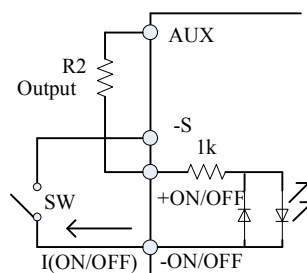



# CFB400W Series Application Note V16 July 2019

## 7. Safety & EMC

### 7.1 Input Fusing and Safety Considerations

The CFB400W series converters have no internal fuse. In order to achieve maximum safety and system protection, always use an input line fuse. We recommended a 80A fast blow type fuse for 24V<sub>in</sub> models, and 40A for 48V<sub>in</sub> models. It is recommended that the circuit have a transient voltage suppressor diode (TVS) across the input terminal to protect the unit against surge or spike voltage and input reverse voltage (as shown).

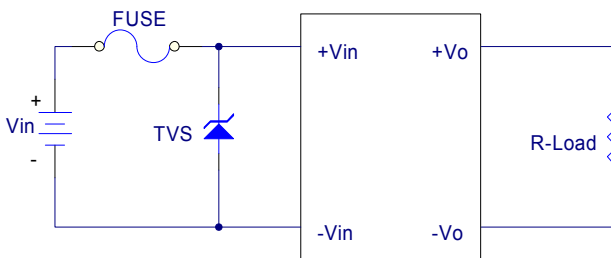

### 7.2 EMC Considerations

#### Suggested Circuits for Conducted EMI CLASS A

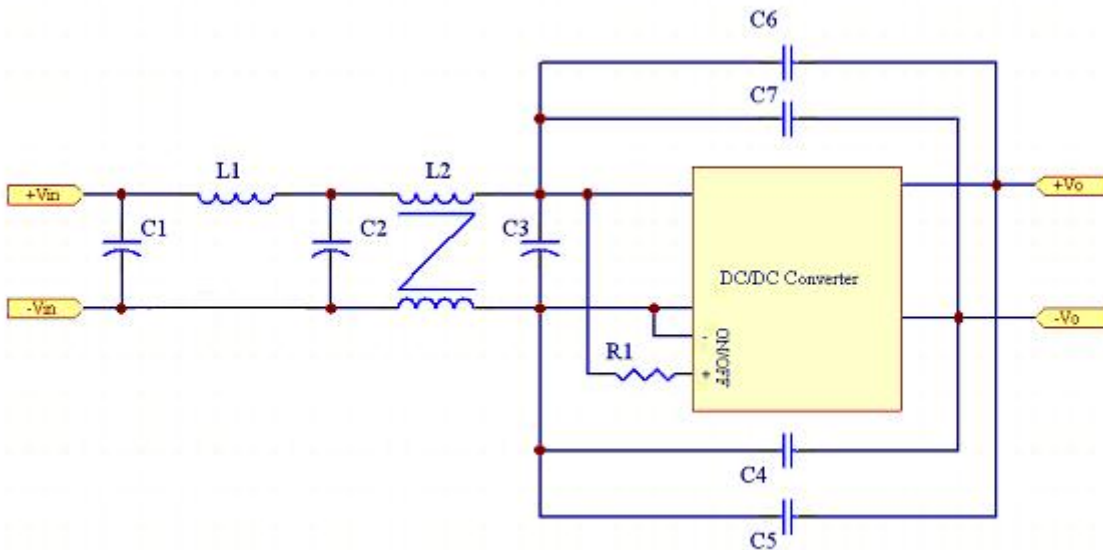

(1) EMI and conducted noise meet EN55032 Class A specifications:

Model No.	C1	C2	C3	C4	C5	C6	C7	L1	L2	R1
CFB400W-24S12	NC	470uF/50V KY	1000uF/50V KY	2200pF/2KV	NC	NC	NC	Short	200uH RM8 SM100	6K (0.5W)
CFB400W-48S48	330uF/100V KMF	330uF/100V KMF	330uF/100V KMF	NC	NC	NC	NC	1uH SPI-13050-1R0	1.5mH CM20*12*10	12K(1.0W)

Note:

C1, C2, C3 is NIPPON CHEMI-CON KY or KMF series aluminum capacitor,  
C4 is ceramic capacitors.

L1: Core TODA ISU SPI-13050-1R0

L2: Core SM RM8 SM100 0.51\*3.25mm/4T\*4 (for CFB400W-24S12)

L2: Core SM CM20\*12\*10 turns double wire (for CFB400W-48S48)



# CFB400W Series Application Note V16 July 2019

## Suggested Circuits for Conducted EMI CLASS B

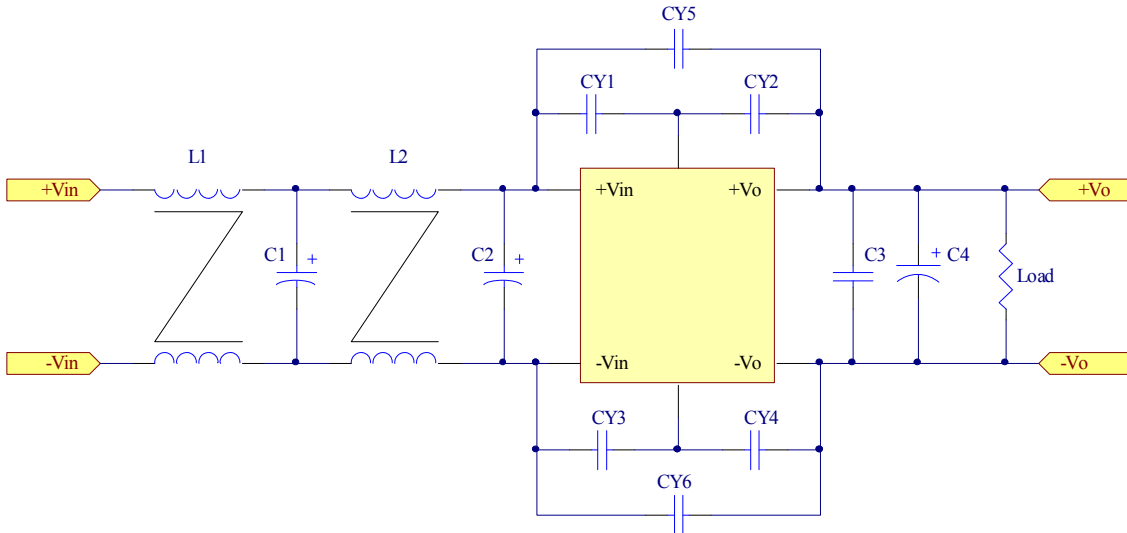

(1) EMI and conducted noise meet EN55032 Class B specifications:

Model No.	C1	C2	C3	CY1, CY2, CY3, CY4	CY5, CY6	L1	L2
CFB400W-24S12	47uF/50V KY	1000uF/50V KY	330uF/100V PW	6800pF/2KV*4	6800pF/2KV*2	0.2mH	1mH
CFB400W-48S12	120uF/100V KY	330uF/100V PW	330uF/100V PW	6800pF/2KV*4 //2200pF/2KV	6800pF/2KV*2	0.2mH	1mH

Note:

C1, C2, C3 is NIPPON CHEMI-CON KY series or NICHICON PW series aluminum capacitor, CY1, CY2, CY3, CY4, CY5, CY6 are ceramic capacitors.

L1: Core SM CM20\*12\*105 turns double wire, L2: Core: SM150 T31\*19\*13, 7 turns double wire

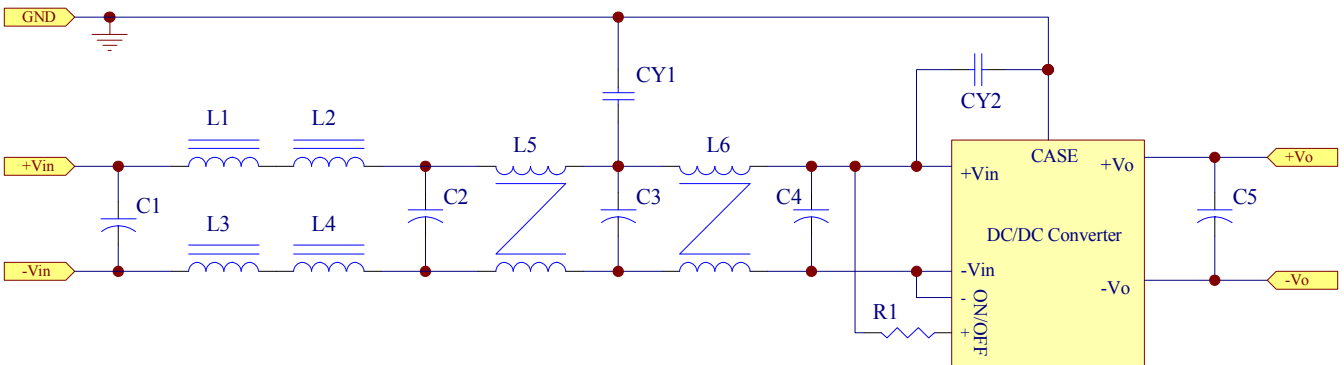

(1) EMI and conducted noise meet EN55032 Class B specifications:

Model No.	C1	C2	C3	C4	C5	CY1	CY2
CFB400W-24S24	470uF/50V PS	470uF/50V PS	4.7uF/100V 1812	1000uF/50V KY	330uF/50V KY	0.01uF/250V*4 Y2 Cap.	2200pF/250V*2 Y2 Cap.
	L1, L2, L3, L4	L5, L6	R1				
	100nH	0.5mH	6K (0.5W)				

Note:

C1, C2, C4, C5 is NIPPON CHEMI-CON KY series or NICHICON PS series aluminum capacitor, CY1, CY2 are ceramic capacitors.

L1, L2, L3, L4: PA0511.900NLT Puls, L5, L6: 744 825 350 5 Würth



# CFB400W Series Application Note V16 July 2019

## Suggested Circuits for Conducted EMI CLASS B

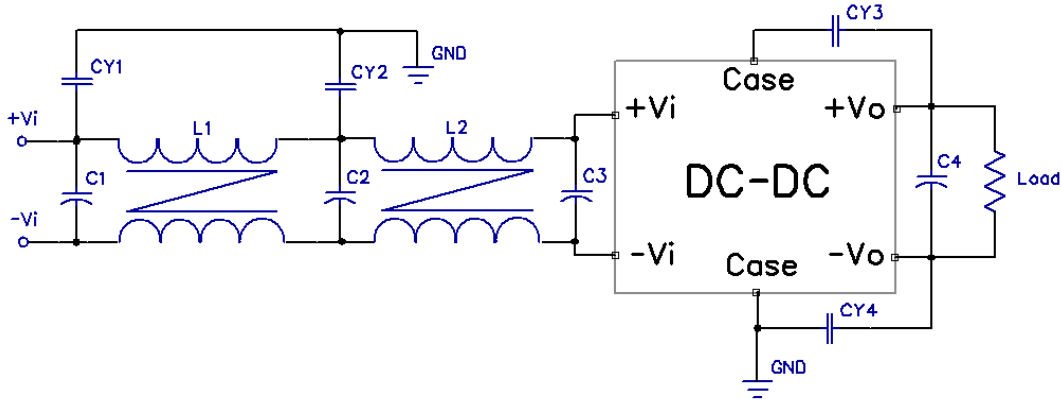

(1) EMI and conducted noise meet EN55032 Class B specifications:

Model No.	C1	C2	C3	C4	CY1	CY2	CY3	CY4	L1	L2
CFB400W-48S24	470uF/100V PS	470uF/100V PS	470uF/100V PS	330uF/50V KY	470pF 250V	4700pF 250V	0.047uF 1KV	0.047uF 1KV	2mH	2mH

Note:

C1, C2, C3, C4 is NIPPON CHEMI-CON KY series or NICHICON PS series aluminum capacitor,

CY1, CY2, CY3, CY4 are ceramic capacitors.

L1: SC15-200 KEMET



# CFB400W Series Application Note V16 July 2019

## 8. Part Number

Format: CFB400W – II X 00 L

Parameter	Series	Nominal Input Voltage	Number of Outputs	Output Voltage	Remote ON/OFF Logic
Symbol	CFB400W	II	X	00	L
Value	CFB400W	24: 24 Volts 48: 48 Volts	S: Single	05: 05 Volts 12: 12 Volts 24: 24 Volts 28: 28 Volts 48: 48 Volts	None: Negative P: Positive

## 9. Mechanical Specifications

### 9.1 Mechanical Outline Diagrams

All Dimensions In Inches(mm)  
 Tolerances Inches: .XX±0.02 .XXX±0.010 ±0.004  
 Millimeters: .X±0.5 .XX±0.25 ±0.1

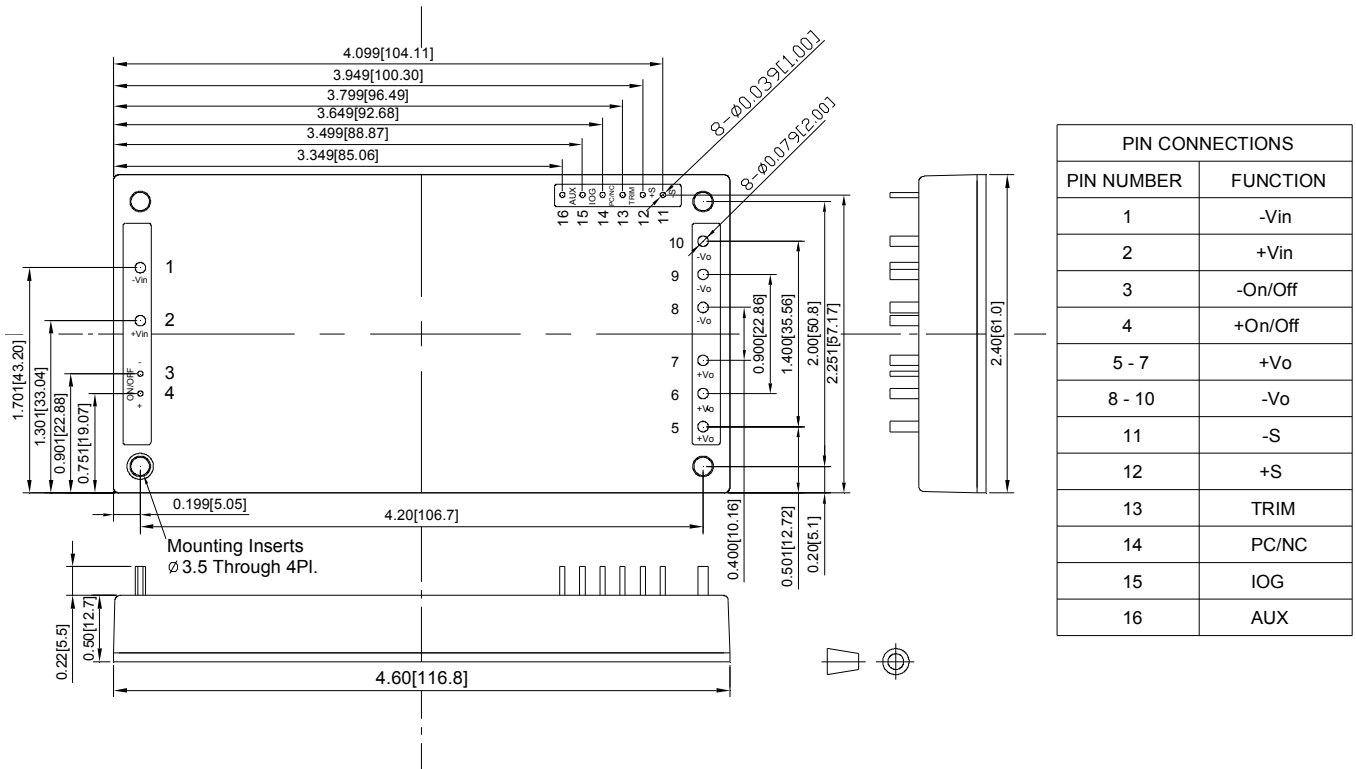

CFB400W Mechanical Outline Diagram

## CINCON ELECTRONICS CO., LTD.

### Headquarters:

14F, No.306, Sec.4, Hsin Yi Rd.  
 Taipei, Taiwan  
 Tel: 886-2-27086210  
 Fax: 886-2-27029852  
 E-mail: sales@cincon.com.tw  
 Web Site: http://www.cincon.com

### Factory:

No. 8-1, Fu Kung Rd.  
 Fu Hsing Industrial Park  
 Fu Hsing Hsiang,  
 Chang Hua Hsien, Taiwan  
 Tel: 886-4-7690261  
 Fax: 886-4-7698031

### Cincon North America:

1655 Mesa Verde Ave. Ste 180  
 Ventura, CA 93003  
 Tel: 805-639-3350  
 Fax: 805-639-4101  
 E-mail: info@cincon.com