

Current Transducer LH 100-P

$I_{PN} = 100\text{ A}$

For the electronic measurement of current: DC, AC, pulsed..., with galvanic separation between the primary and the secondary circuit.

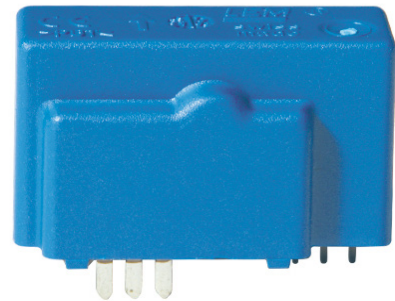

Features

- Closed loop (compensated) current transducer
- PCB mounting
- Current output.

Advantages

- High accuracy
- Very low offset
- Very low offset drift over temperature.

Applications

- AC variable speed and servo motor drives
- Static converters for DC motor drives
- Battery supplied applications
- Uninterruptible Power Supplies (UPS)
- Switched Mode Power Supplies (SMPS)
- Power supplies for welding applications
- Solar inverters.

Standards

- IEC 61800-1: 1997
- IEC 61800-2: 2015
- IEC 61800-3: 2004
- IEC 61800-5-1: 2007
- IEC 62109-1: 2010
- IEC 62477-1: 2012
- UL 508: 2013.

Application Domain

- Industrial.

Absolute maximum ratings

Parameter	Symbol	Unit	Value
Maximum supply voltage (working) (-40 ... 85 °C)	$U_{C\ max}$	V	±15.75
Maximum primary conductor temperature	$T_{B\ max}$	°C	100
Maximum steady state primary current (-40 ... 85 °C)	$I_{P\ N\ max}$	A	100

Stresses above these ratings may cause permanent damage.
Exposure to absolute maximum ratings for extended periods may degrade reliability.

UL 508: Ratings and assumptions of certification

File # E189713 Volume: 2 Section: 10

Standards

- USR indicates investigation to the Standard for Industrial Control Equipment UL 508.
- CNR indicates investigation to the Canadian standard for Industrial Control Equipment CSA C22.2 No. 14-13

Conditions of acceptability

When installed in the end-use equipment, with primary feed through potential involved of 600 V AC/DC, consideration shall be given to the following:

- 1 - *These products must be mounted in a suitable end-use enclosure.*
- 2 - *The secondary pin terminals have not been evaluated for field wiring.*
- 3 - *Low voltage control circuit shall be supplied by an isolating source (such as transformer, optical isolator, limiting impedance or electro-mechanical relay).*
- 4 - *Based on the temperature test performed on all series, the primary bar or conductor shall not exceed 100 °C in the end use application.*

Marking

Only those products bearing the UL or UR Mark should be considered to be Listed or Recognized and covered under UL's Follow-Up Service. Always look for the Mark on the product.

Insulation coordination

Parameter	Symbol	Unit	Value	Comment
RMS voltage for AC insulation test, 50 Hz, 1 min	U_d	kV	5	
Impulse withstand voltage 1.2/50 μ s	U_{Ni}	kV	12	
Insulation resistance	R_{INS}	G Ω	≥ 1	measured at 500 V DC
Partial discharge extinction RMS voltage @ 10 pC	U_e	kV	> 2	
Clearance (pri. - sec.)	d_{Cl}	mm	See dimensions drawing on page 11	
Creepage distance (pri. - sec.)	d_{Cp}	mm		
Case material	-	-	V0	According to UL 94
Comparative tracking index	CTI		600	
Application example		V	600	Reinforced insulation, CAT III, PD 2 non uniform field according to IEC 61800-5-1
Application example		V	1000	Basic insulation, CAT III, PD 2 non uniform field according to IEC 61800-5-1

Environmental and mechanical characteristics

Parameter	Symbol	Unit	Min	Typ	Max	Comment
Ambient operating temperature	T_A	$^{\circ}$ C	-40		85	
Ambient storage temperature	$T_{A\text{st}}$	$^{\circ}$ C	-50		90	
Mass	m	g		23		

Electrical data

At $T_A = 25\text{ °C}$, $\pm U_C = \pm 15\text{ V}$, $R_M = 1\ \Omega$, unless otherwise noted.

Lines with a * in the conditions column apply over the $-40 \dots 85\text{ °C}$ ambient temperature range.

Parameter	Symbol	Unit	Min	Typ	Max	Comment
Primary nominal RMS current	I_{PN}	A		100		*
Primary current, measuring range	I_{PM}	A	-175		175	* With $R_M \leq 24\ \Omega$ with $U_C = \pm 15\text{ V}$
Measuring resistance	R_M	Ω	10 ¹⁾			* Measuring resistance range is defined in figure 1, 2
Secondary nominal RMS current	I_{SN}	mA		50		*
Resistance of secondary winding	R_S	Ω			94	$R_S(T_A) = R_S \times (1 + 0.004 \times (T_A + \Delta\text{temp} - 25))$ Estimated temperature increase @ I_{PN} is $\Delta\text{temp} = 15\text{ °C}$
Secondary current	I_S	mA	-87.5		87.5	*
Number of secondary turns	N_S			2000		
Theoretical sensitivity		mA/A		0.5		
Supply voltage	$\pm U_C$	V	± 11.4		± 15.75	*
Current consumption	I_C	mA		20 21		$\pm U_C = \pm 12\text{ V}$ $\pm U_C = \pm 15\text{ V}$
Offset current referred to primary	I_O	A	-0.12		0.12	
Offset current referred to secondary		mA	-0.060		0.060	
Overall I_O at $-40 \dots 85\text{ °C}$, referred to primary	\bar{I}_{Oov}	A	-0.18		0.18	*
Overall I_O at $-40 \dots 85\text{ °C}$, referred to secondary		mA	-0.09		0.09	*
Temperature coefficient of I_{OE} , referred to primary	TCI_{OE}	$\mu\text{A/K}$	-400		400	*
Magnetic offset current, after overload referred to secondary	I_{OM}	mA		± 0.04		After $5 \times I_{PN}$
Sensitivity error	ε_S	%	-0.2		0.2	*
Temperature coefficient of S	TCS	ppm/K	-30		30	*
Linearity error	ε_L	% of I_{PN}	-0.1		0.1	*
Total error at I_{PN}	ε_{tot}	%			0.4	*
Error at I_{PN}	ε	%			0.2	*
RMS noise current referred to primary	I_{no}	mA		18		1 Hz to 100 kHz (see figure 4)
Delay time to 10 % of the final output value for I_{PN} step	t_{D10}	ns		200		0 to 100 A, 50 A/ μs $R_M = 10\ \Omega$
Delay time to 90 % of the final output value for I_{PN} step	t_{D90}	ns		500		0 to 100 A, 50 A/ μs , $R_M = 10\ \Omega$ (figure 3); PCB design defined in fig.7
Delay time to 90 % of the final output value for I_{PN} step	t_{D90}	ns		100		0 to 100 A, 50 A/ μs , $R_M = 10\ \Omega$; PCB design defined in fig. 6
Frequency bandwidth	BW	kHz		200		$R_M = 10\ \Omega$; -3 dB

Note: ¹⁾ With $\pm 15\text{ V} \pm 5\%$ as power supply, $T_A = 85\text{ °C}$ and I_{PN} (DC value).

Other values of minimum values according to conditions of use are given in Figure 1, 2.

Typical performance characteristics

Definition of typical, minimum and maximum values

Minimum and maximum values for specified limiting and safety conditions have to be understood as such as well as values shown in “typical” graphs.

On the other hand, measured values are part of a statistical distribution that can be specified by an interval with upper and lower limits and a probability for measured values to lie within this interval.

Unless otherwise stated (e.g. “100 % tested”), the LEM definition for such intervals designated with “min” and “max” is that the probability for values of samples to lie in this interval is 99.73 %.

For a normal (Gaussian) distribution, this corresponds to an interval between -3 sigma and $+3$ sigma. If “typical” values are not obviously mean or average values, those values are defined to delimit intervals with a probability of 68.27 %, corresponding to an interval between $-\text{sigma}$ and $+\text{sigma}$ for a normal distribution.

Typical, maximal and minimal values are determined during the initial characterization of the product

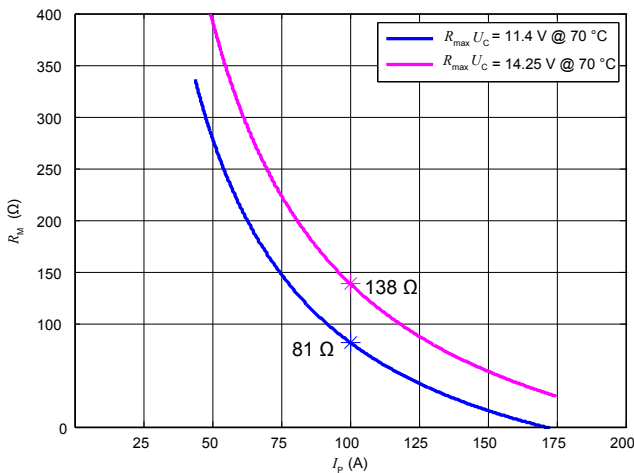

Figure 1: Maximum measuring resistance @ 70 °C in DC

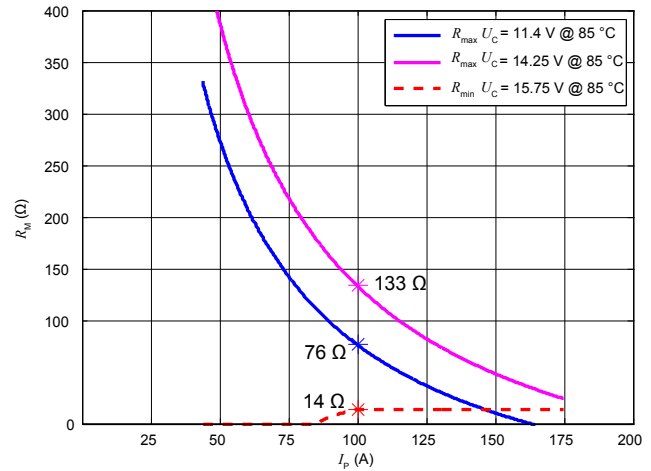

Figure 2: Maximum measuring resistance @ 85 °C in DC

$$R_{M \max} = N_S \times \frac{U_{C \min} - 1.5 \text{ V}}{I_p} - R_{S \max}$$

The measuring resistance (R_M) has to be properly defined in order to guarantee the optimal transducer performance. Maximum measuring resistance ($R_{M \max}$) is based on the maximum current that must be measured by the transducer. The simple formula $R_{M \max}$ is shown above.

Minimum measuring resistance ($R_{M \min}$) is based on the maximum heat dissipation capacity of the transducer.

It depends on the following working conditions: supply voltage U_C , ambient temperature T_A and the nominal primary RMS current ($I_{P,N}$).

Minimum R_M value can be as low as 0 Ω , and this is normally the case when the transducer is supplied with a low supply voltage $U_C = \pm 12 \text{ V}$.

In figure 1 the minimum R_M value data is omitted whenever it is equal to 0 Ω .

Typical performance characteristics continued

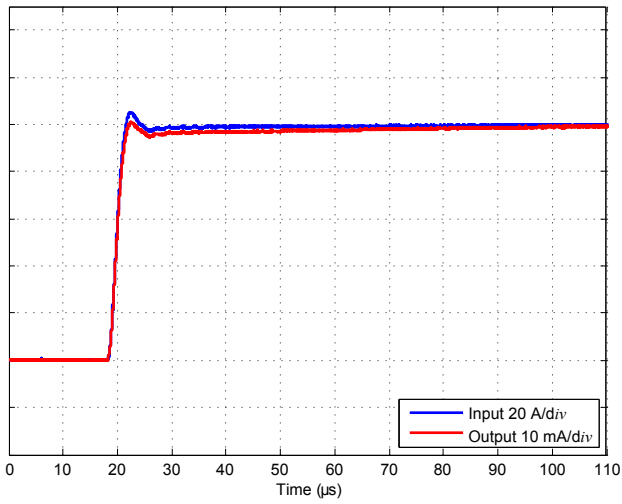

Figure 3: Typical delay time (0 to 100 A, 50 A/μs with $R_M = 10 \Omega$)

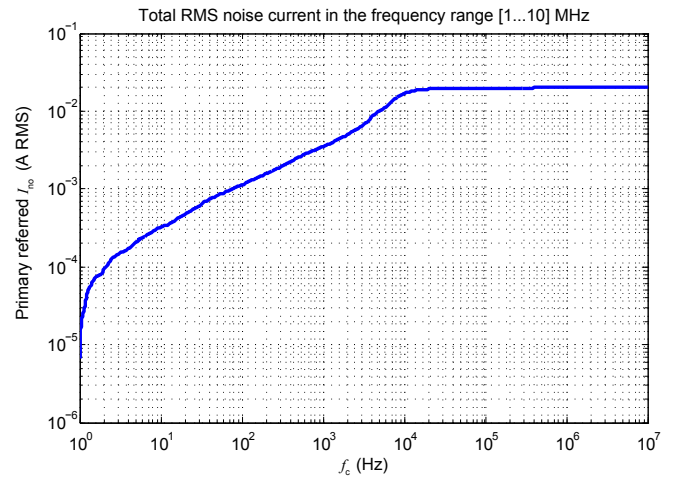

Figure 4: Typical total RMS noise current (primary referred, RMS) with $R_M = 10 \Omega$

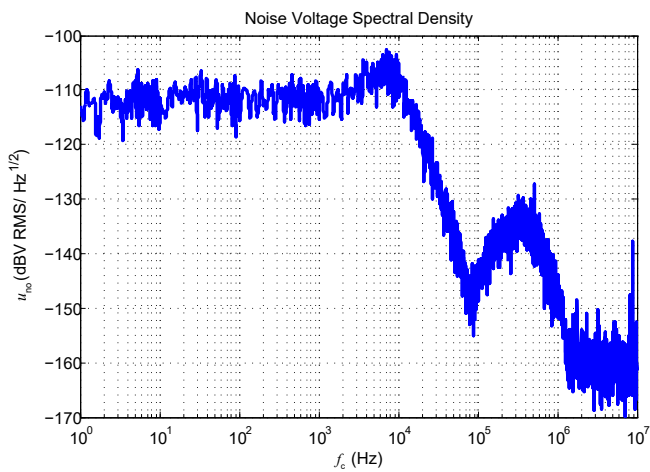

Figure 5: Typical noise voltage spectral density u_{no} with $R_M = 10 \Omega$

High and low speed PCB designs

The PCB design is very important to achieve good response to high-frequency primary current in terms of accuracy and bandwidth. High speed PCB design, as the one shown here below, allows the transducer to obtain lower delay times to high varying primary current. In order to achieve the highest bandwidth possible the loop of the primary current traces at the transducer back should be as tight as possible.

On the other hand, high speed PCB design requires more PCB area for the primary current traces compared to low speed PCB design. The customer must define the optimal PCB design according to the application specifications.

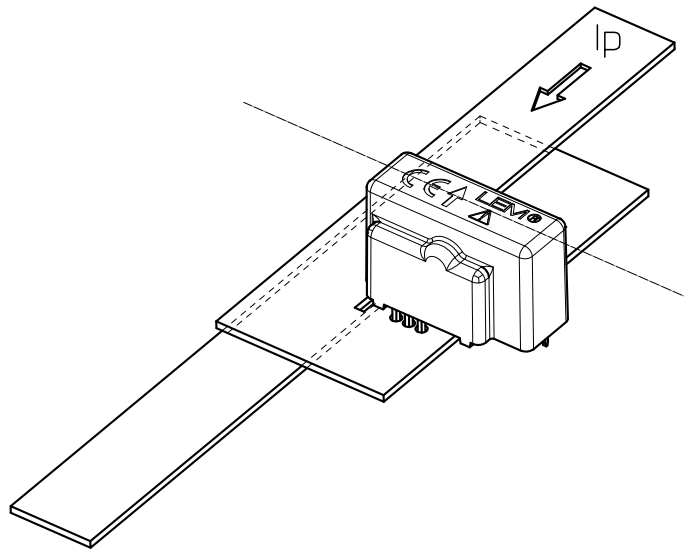

Figure 6: High speed PCB design

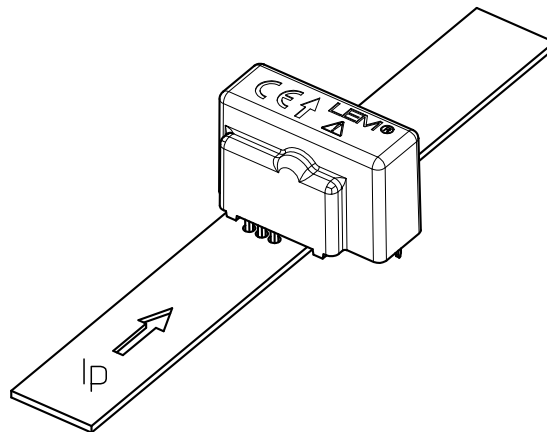

Figure 7: Low speed PCB design

Performance parameters definition

Ampere-turns and amperes

The transducer is sensitive to the primary current linkage θ_p (also called ampere-turns).

$$\theta_p = N_p \cdot I_p \text{ (At)}$$

Where N_p is the number of primary turn (depending on the connection of the primary jumpers)

Caution: As most applications will use the transducer with only one single primary turn ($N_p = 1$), much of this datasheet is written in terms of primary current instead of current linkages. However, the ampere-turns (At) unit is used to emphasize that current linkages are intended and applicable.

Transducer simplified model

The static model of the transducer at temperature T_A is:

$$I_S = S \cdot \theta_p + \varepsilon$$

In which

$$\varepsilon = I_{OE} + I_{OT}(T_A) + \varepsilon_s \cdot \theta_p \cdot S + \varepsilon_L(\theta_{Pmax}) \cdot \theta_{Pmax} \cdot S + TCS \cdot (T_A - 25) \cdot \theta_p \cdot S$$

With:

- $\theta_p = N_p \cdot I_p$: primary current linkage (At)
- θ_{Pmax} : max primary current linkage applied to the transducer
- I_S : secondary current (A)
- T_A : ambient operating temperature ($^{\circ}\text{C}$)
- I_{OE} : electrical offset current (A)
- $I_{OT}(T_A)$: temperature variation of I_O at temperature T_A ($^{\circ}\text{C}$)
- S : sensitivity of the transducer (A/At)
- TCS : temperature coefficient of G
- ε_s : sensitivity error
- $\varepsilon_L(\theta_{Pmax})$: linearity error for θ_{Pmax}

This model is valid for primary ampere-turns θ_p between $-\theta_{Pmax}$ and $+\theta_{Pmax}$ only.

Sensitivity and linearity

To measure sensitivity and linearity, the primary current (DC) is cycled from 0 to I_p , then to $-I_p$ and back to 0 (equally spaced $I_p/10$ steps). The sensitivity S is defined as the slope of the linear regression line for a cycle between $\pm I_{PN}$.

The linearity error ε_L is the maximum positive or negative difference between the measured points and the linear regression line, expressed in % of I_{PN} .

Magnetic offset

The magnetic offset current I_{OM} is the consequence of a current on the primary side ("memory effect" of the transducer's ferro-magnetic parts). It is measured using the following primary current cycle. I_{OM} depends on the current value I_{P1} ($I_{P1} > I_{PM}$).

$$I_{OM} = \frac{I_S(t_1) - I_S(t_2)}{2} \cdot \frac{1}{S}$$

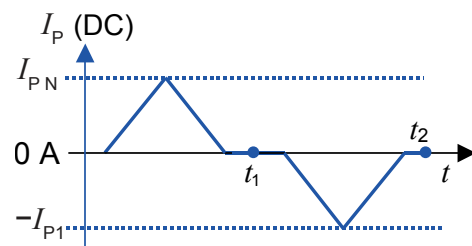

Figure 8: Current cycle used to measure magnetic and electrical offset (transducer supplied)

Performance parameters definition

Electrical offset

The electrical offset current I_{OE} can either be measured when the ferro-magnetic parts of the transducer are:

- completely demagnetized, which is difficult to realize,
- or in a known magnetization state, like in the current cycle shown in figure 8.

Using the current cycle shown in figure 8, the electrical offset is:

$$I_{OE} = \frac{I_s(t_1) + I_s(t_2)}{2}$$

The temperature variation I_{OT} of the electrical offset current I_{OE} is the variation of the electrical offset from 25 °C to the considered temperature:

$$I_{OT}(T) = I_{OE}(T) - I_{OE}(25^\circ\text{C})$$

Note: the transducer has to be demagnetized prior to the application of the current cycle (for example with a demagnetization tunnel).

Total error

The total error ε_{tot} is the error at $\pm I_{PN}$, relative to the rated value I_{PN} . The total error ε_{tot} at 25 °C includes the electrical offset, the magnetic offset, the sensitivity error and the linearity error, expressed in % of I_{PN} .

The formula for total error ε_{tot} is:

$$\varepsilon_{tot} \text{ at } I_P = \left(\frac{I_{out} \text{ at } I_P}{S_N} - I_{P.ref} \right) \times \frac{100}{I_{PN}} \text{ [in \% of } I_{PN}]$$

Error

The error ε is defined as the global error for each measured point at a given primary current without taking into account the electrical offset, expressed in % of I_{PN} .

The formula for error ε is:

$$\varepsilon \text{ at } I_P = \varepsilon_s \text{ at } I_P - I_{OE} \text{ referred to primary [in \% of } I_{PN}]$$

Delay times

The delay time t_{D10} and the delay time t_{D90} are shown in figure 9. Both depend on the primary current di/dt . They are measured at nominal ampere-turns.

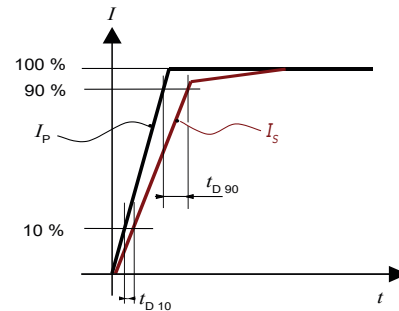

Figure 9: t_{D90} (delay time @ 10%) and t_{D10} (delay time @ 10%)

Safety

This transducer must be used in limited-energy secondary circuits according to IEC 61010-1.



This transducer must be used in electric/electronic equipment with respect to applicable standards and safety requirements in accordance with the manufacturer's operating instructions.



Caution, risk of electrical shock

When operating the transducer, certain parts of the module can carry hazardous voltage (e.g. primary busbar, power supply). Ignoring this warning can lead to injury and/or cause serious damage.

This transducer is a build-in device, whose conducting parts must be inaccessible after installation.

A protective housing or additional shield could be used. Main supply must be able to be disconnected.

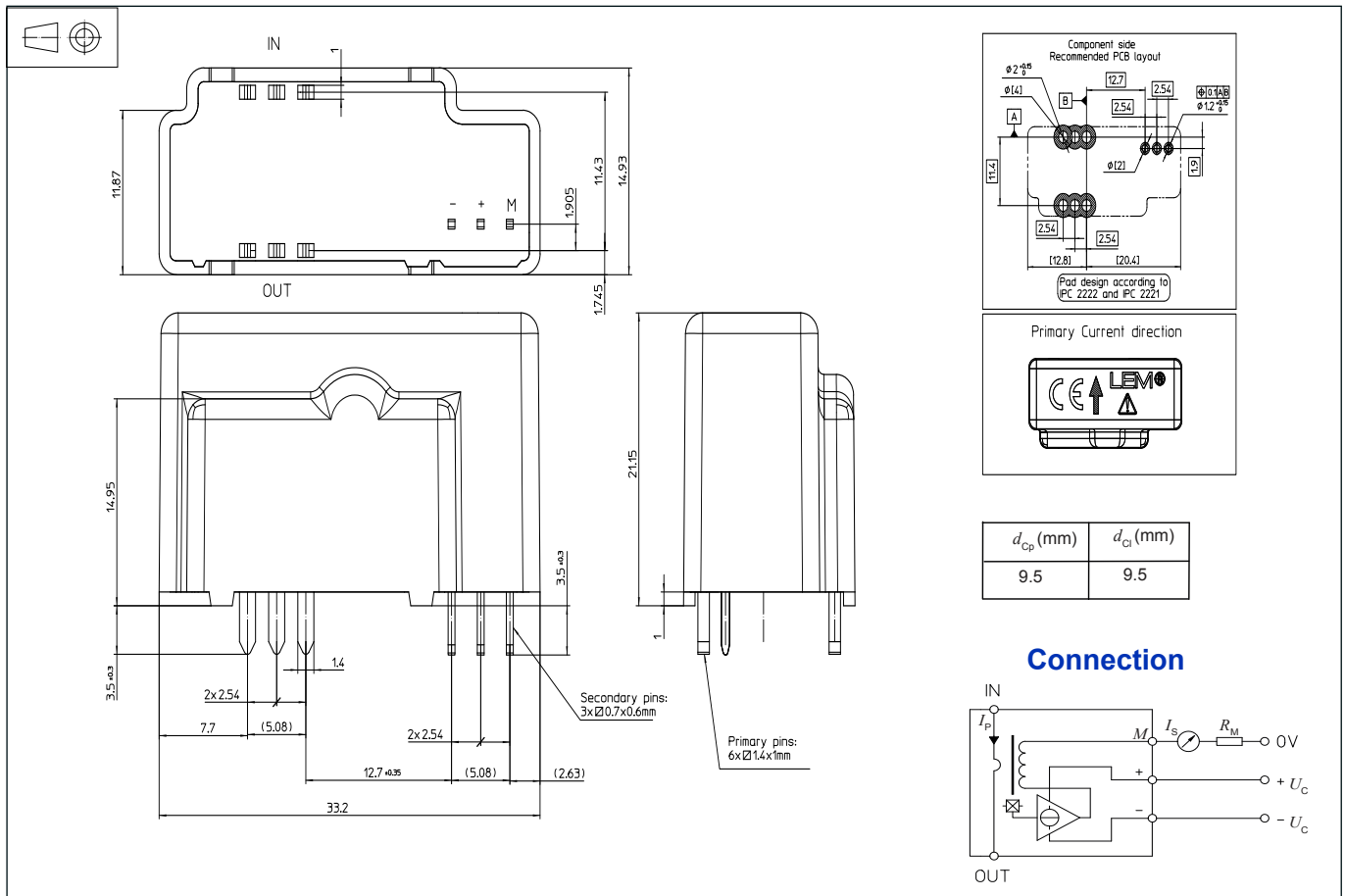
Dimensions (in mm)

Number of primary turns	Primary current nominal I_{PN} [A]	Primary current maximum I_P [A]	Nominal output current I_{SN} [mA]	Turns ratio N_P/N_S	Primary resistance R_P [mΩ]	Primary insertion inductance L_P [μH]
1	100	175	50	1 : 2000	0.08	0.007

Mechanical characteristics

- General tolerance ± 0.2 mm
- Fastening & connection of primary
Recommended PCB hole 2 mm
- Fastening & connection of secondary
Recommended PCB hole 1.2 mm

Remarks

- I_S is positive when I_P flows from terminals (IN) to terminals (OUT).
- The jumper temperature and PCB should not exceed 100 °C.
- This is a standard model. For different versions (supply voltages, turns ratios, unidirectional measurements...), please contact us.
- Installation of the transducer must be done, unless otherwise specified on the datasheet, according to LEM Transducer Generic Mounting Rules. Please refer to LEM document N°ANE120504 available on our Web site: <https://www.lem.com/en/file/3137/download/>.