

Ref: GO 12-SME/SP2, GO 20-SME/SP2

For the electronic measurement of current: DC, AC, pulsed..., with galvanic separation between the primary and the secondary circuit.

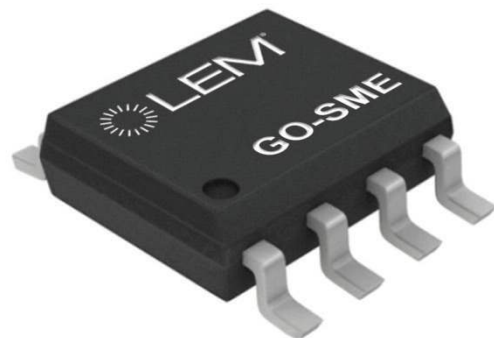

Features

- Hall effect measuring principle
- Galvanic separation between primary and secondary circuit
- Insulated test voltage 2500 V RMS
- Low power consumption
- Extremely low profile
- Delay time 2 μ s.

Special feature

- Ratiometric output.

Advantages

- Small size and space saving
- High immunity to external interference
- High insulation capability
- Low electrical resistance (0.9 m Ω)
- No magnetic hysteresis
- Robust against external fields and cross-talk.

Applications

- Small drives
- HVAC
- Appliances
- E-Bikes.

Standards

- IEC 61800-5-1: 2007
- IEC 62109-1: 2010
- IEC 60950-1: 2005
- UL 1577: 2014.

Application Domains

- Industrial.

Absolute maximum ratings

Parameter	Symbol	Unit	Min	Typ	Max	Conditions
Maximum supply voltage (not destructive)	$U_{C\ max}$	V			8	
Maximum supply voltage (not entering non-standard modes)					6.5	
Primary withstand peak current (maximum)	$\hat{I}_{P\ max}$	A			±200	$T_A = 25\ ^\circ\text{C}$, 1 ms pulse
Maximum electrostatic discharge voltage (HMB-Human Body Model)	$U_{ESD\ HBM}$	V			2000	AEC-Q100-002 REV D
Maximum electrostatic discharge voltage (CDM-Charged Device Model)	$U_{ESD\ CDM}$	V			500	AEC-Q100-011 REV B
Maximum output current source	$I_{out\ max}$	mA			25	
Maximum output current sink	$I_{out\ max}$	mA			50	
Maximum junction temperature	$T_{J\ max}$	°C			150	

Insulation coordination

Parameter	Symbol	Unit	Value	Comment
RMS voltage for AC insulation test, 50 Hz, 1 min	U_d	V	2500	According to IEC 60664-1
RMS voltage for AC insulation test, 60 Hz, 1 min	U_d	V	2500	According to UL 1577
RMS voltage for AC insulation test, 50 Hz, 1 min	U_d	V	2500	According to IEC 60950-1
Impulse withstand voltage 1.2/50 μs	U_{Ni}	V	4000	According to IEC 61800-5-1 , IEC 62109-1, UL 60950-1
Partial discharge RMS test voltage ($q_m < 5\ \text{pC}$)	U_t	V	850	Primary/secondary Corresponds to a recurring peak voltage of 728 V peak-to-peak According to IEC 61800-5-1, IEC 62109-1
Clearance (pri. - sec.)	d_{Cl}	mm	4	Shortest distance through air
Creepage distance (pri. - sec.)	d_{Cp}			Shortest path along body
Comparative tracking index	CTI		600	
Application example		V RMS	300	Basic insulation according to IEC 61800-5-1, IEC 62109-1, IEC 60950-1, CAT II, PD2

UL 1577 Non Optical isolating devices - Component

File # E486776, Vol 1

Single protection, non-optical isolators, 2500 vac insulation

Standards

- UL 1577, Optical Isolators;
- CSA Component Acceptance Service Notice N°. 5 A, Component Acceptance Service for Optocouplers and Related Devices.

Marking

Only those products bearing the UL or UR Mark should be considered to be Listed or Recognized and covered under UL's Follow-Up Service. Always look for the Mark on the product.

Environmental and mechanical characteristics

Parameter	Symbol	Unit	Min	Typ	Max	Conditions
Ambient operating temperature	T_A	°C	-40		125	
Ambient storage temperature	$T_{A\text{st}}$	°C	-55		165	
Resistance of the primary @ $T_A = 25\text{ °C}$	R_p	mΩ		0.9		
Thermal resistance, junction to board ¹⁾	R_{thJB}	K/W		15		
Time constant	t	s		1		To reach steady state

Note: ¹⁾ Done on LEM evaluation board PCB 2320.

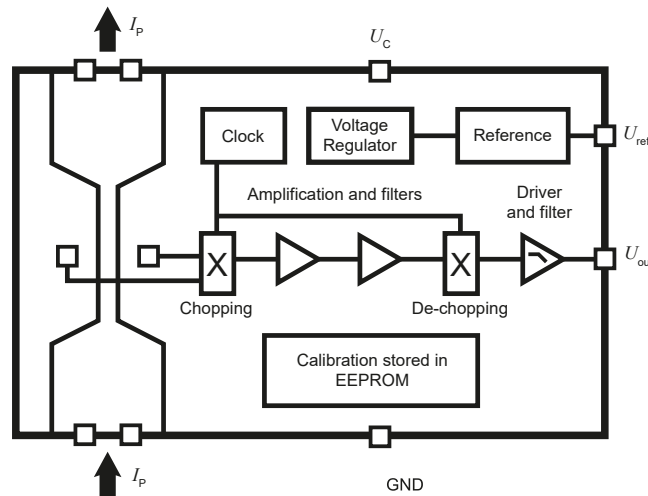
Block diagram

Connection diagram

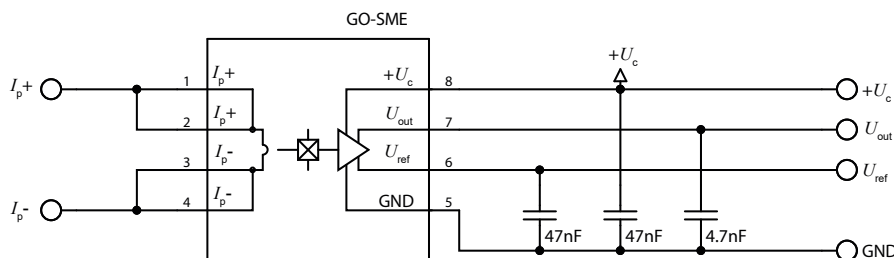
Pin#	Name	Function
From 1 to 2	I_{p+}	Input of the primary current
From 3 to 4	I_{p-}	Output of the primary current
5	GND	Ground
6	U_{ref}	Reference voltage (output)
7	U_{out}	Output voltage
8	U_c	Supply voltage



Electrical data GO 12-SME/SP2

 At $T_A = -40\text{ °C} \dots 125\text{ °C}$, $U_C = +5\text{ V}$, $R_L = 10\text{ k}\Omega$ unless otherwise noted.

Parameter	Symbol	Unit	Min	Typ	Max	Conditions
Primary nominal RMS current	I_{PN}	A		12		
Primary current, measuring range	I_{PM}	A	-30.3		30.3	
Supply voltage ¹⁾	U_C	V	4.5	5	5.5	
Current consumption	I_C	mA		20	26	
Reference voltage (output)	U_{ref}	V		$U_C/2$		@ 25 °C
Reference voltage (input)	U_{ref}	V	0.5		2.6	$U_C = 5\text{ V}$
Output voltage range @ I_{PM}	$U_{out} - U_{ref}$	V	-2		2	
Output internal resistance	R_{out}	Ω			5	Up to 10 kHz
Reference internal resistance	R_{ref}	Ω	120	200	333	
Load capacitance	C_L	nF	0		6	
Nominal sensitivity	S_N	mV/A		66		
Electrical offset voltage @ $I_{PN} = 0$	U_{OE}	mV	-5		5	$T_A = 25\text{ °C}$, $U_{out} - U_{ref}$ @ $U_{ref} = 2.5$ and 1.65 V
Electrical offset current referred to I_{PN}	I_{OE}	mA	-75		75	$T_A = 25\text{ °C}$
Temperature coefficient of U_{ref}	TCU_{ref}	ppm/K	-170		170	$U_{ref} = 2.5$ and 1.65 V
Temperature coefficient of U_{OE}	TCU_{OE}	mV/K	-0.075		0.075	
Temperature coefficient of I_{OE}	TCI_{OE}	mA/K	-1.14		1.14	
Temperature coefficient of S	TCS	ppm/K	-150		150	
Delay time to 90 % of the final output value for I_{PN} step	t_{D90}	μs			2	
Delay time to 10 % of the final output value for I_{PN} step	t_{D10}	μs			1.5	
Frequency bandwidth -3 dB, $T_A = 25\text{ °C}$	BW	KHz		300		
Noise voltage spectral density	u_{no}	$\mu\text{V}/\text{Hz}^{1/2}$		14.5		NBW = 1 kHz ... 100 kHz
Sensitivity error	ε_S	%	-1		1	Factory adjustment
Linearity error 0 ... I_{PN}	ε_L	% @ I_{PN}	-0.3		0.3	
Linearity error 0 ... I_{PM}	ε_L	% @ I_{PM}	-0.6		0.6	
Sum of sensitivity and linearity error @ I_{PN} @ $T_A = 25\text{ °C}$	ε_{SL25}	% @ I_{PN}	-1.3		1.3	$T_A = 25\text{ °C}$
Sum of sensitivity and linearity error @ I_{PN} @ $T_A = 85\text{ °C}$ ²⁾	ε_{SL85}	% @ I_{PN}	-3.1		3.1	
Sum of sensitivity and linearity error @ I_{PN} @ $T_A = 105\text{ °C}$ ²⁾	ε_{SL105}	% @ I_{PN}	-3.7		3.7	
Sum of sensitivity and linearity error @ I_{PN} @ $T_A = 125\text{ °C}$ ²⁾	ε_{SL125}	% @ I_{PN}	-4.3		4.3	

Notes: ¹⁾ The output voltage U_{out} is fully ratiometric. The offset and sensitivity are dependent on the supply voltage U_C relative to the following formula:

$$I_P = \left(\frac{5}{U_C} \times U_{out} - U_{ref} \right) \times \frac{1}{S} \text{ with } S \text{ in (V/A)}$$

$$\varepsilon_{SL}(T_A) = \varepsilon_{SL25} + \left(TCS + \frac{TCI_{OE}}{I_{PN}} \right) \times |T_A - 25|$$

Electrical data GO 20-SME/SP2

 At $T_A = -40\text{ °C} \dots 125\text{ °C}$, $U_C = +5\text{ V}$, $R_L = 10\text{ k}\Omega$ unless otherwise noted.

Parameter	Symbol	Unit	Min	Typ	Max	Conditions
Primary nominal RMS current	I_{PN}	A		20		
Primary current, measuring range	I_{PM}	A	-50		50	
Supply voltage ¹⁾	U_C	V	4.5	5	5.5	
Current consumption	I_C	mA		20	26	
Reference voltage (output)	U_{ref}	V		$U_C/2$		@ 25 °C
Reference voltage (input)	U_{ref}	V	0.5		2.6	$U_C = 5\text{ V}$
Output voltage range @ I_{PM}	$U_{out} - U_{ref}$	V	-2		2	
Output internal resistance	R_{out}	Ω			5	Up to 10 kHz
Reference internal resistance	R_{ref}	Ω	120	200	333	
Load capacitance	C_L	nF	0		6	
Nominal sensitivity	S_N	mV/A		40		
Electrical offset voltage @ $I_{PN} = 0$	U_{OE}	mV	-5		5	$T_A = 25\text{ °C}$, $U_{out} - U_{ref}$ @ $U_{ref} = 2.5\text{ V}$
Electrical offset current referred to I_{PN}	I_{OE}	mA	-125		125	$T_A = 25\text{ °C}$
Temperature coefficient of U_{ref}	TCU_{ref}	ppm/K	-170		170	$U_{ref} = 1.65\text{ V}$
Temperature coefficient of U_{OE}	TCU_{OE}	mV/K	-0.075		0.075	
Temperature coefficient of I_{OE}	TCI_{OE}	mA/K	-1.88		1.88	
Temperature coefficient of S	TCS	ppm/K	-150		150	
Delay time to 90 % of the final output value for I_{PN} step	t_{D90}	μs			2	
Delay time to 10 % of the final output value for I_{PN} step	t_{D10}	μs			1.5	
Frequency bandwidth -3 dB, $T_A = 25\text{ °C}$	BW	KHz		300		
Noise voltage spectral density	u_{no}	$\mu\text{V}/\text{Hz}^{1/2}$		7		NBW = 1 kHz ... 100 kHz
Sensitivity error	ε_S	%	-1		1	Factory adjustment
Linearity error 0 ... I_{PN}	ε_L	% @ I_{PN}	-0.3		0.3	
Linearity error 0 ... I_{PM}	ε_L	% @ I_{PM}	-0.6		0.6	
Sum of sensitivity and linearity error @ I_{PN} @ $T_A = 25\text{ °C}$	ε_{SL25}	% @ I_{PN}	-1.3		1.3	$T_A = 25\text{ °C}$
Sum of sensitivity and linearity error @ I_{PN} @ $T_A = 85\text{ °C}$ ²⁾	ε_{SL85}	% @ I_{PN}	-3.1		3.1	
Sum of sensitivity and linearity error @ I_{PN} @ $T_A = 105\text{ °C}$ ²⁾	ε_{SL105}	% @ I_{PN}	-3.7		3.7	
Sum of sensitivity and linearity error @ I_{PN} @ $T_A = 125\text{ °C}$ ²⁾	ε_{SL125}	% @ I_{PN}	-4.3		4.3	

Notes: ¹⁾ The output voltage U_{out} is fully ratiometric. The offset and sensitivity are dependent on the supply voltage U_C relative to the following formula:

$$I_P = \left(\frac{5}{U_C} \times U_{out} - U_{ref} \right) \times \frac{1}{S} \text{ with } S \text{ in (V/A)}$$

$$\varepsilon_{SL}(T_A) = \varepsilon_{SL25} + \left(TCS + \frac{TCI_{OE}}{I_{PN}} \right) \times |T_A - 25|$$

Dimensions (in mm)

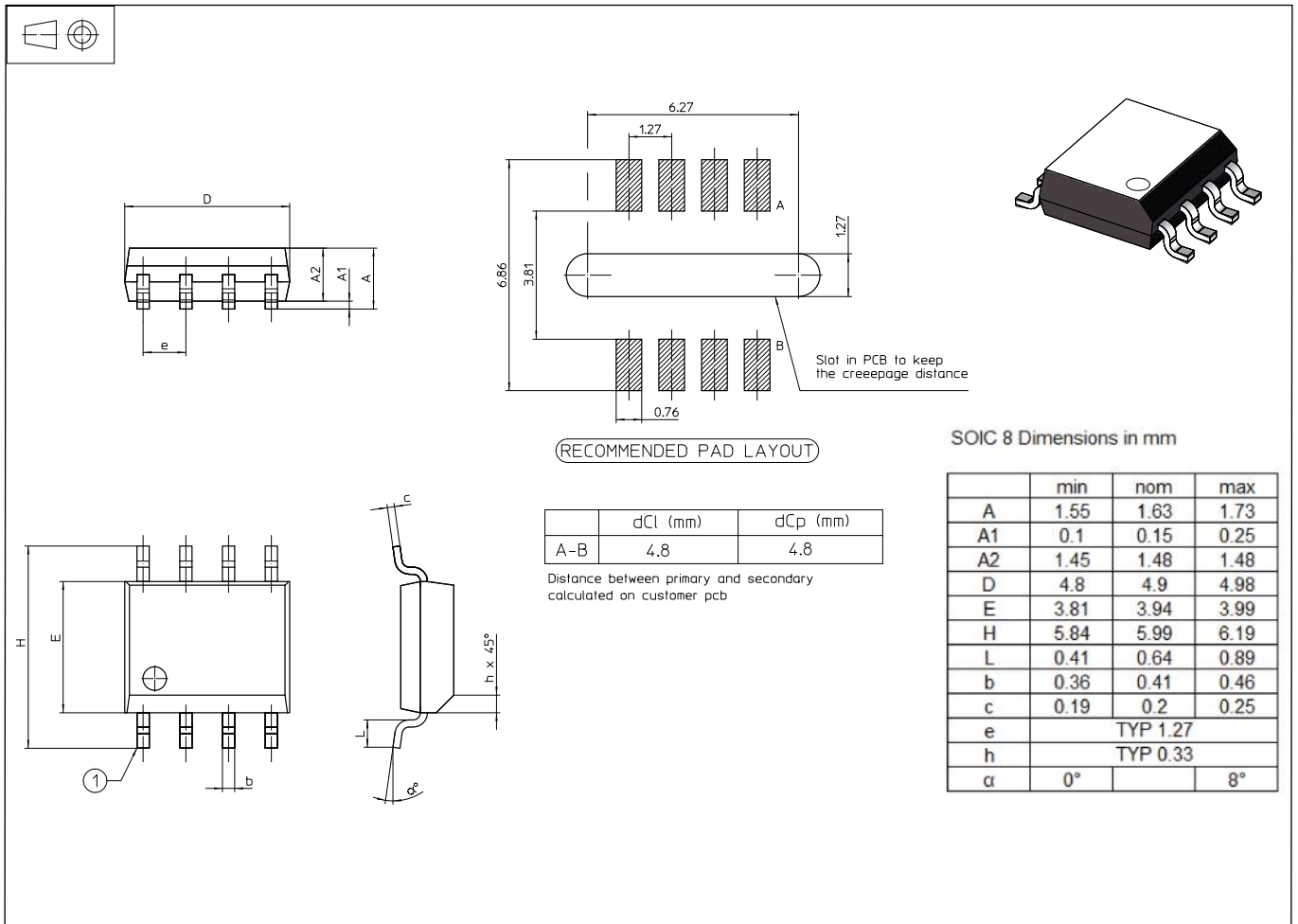

Tape and reel dimensions (in mm)

Leader & Trailer:

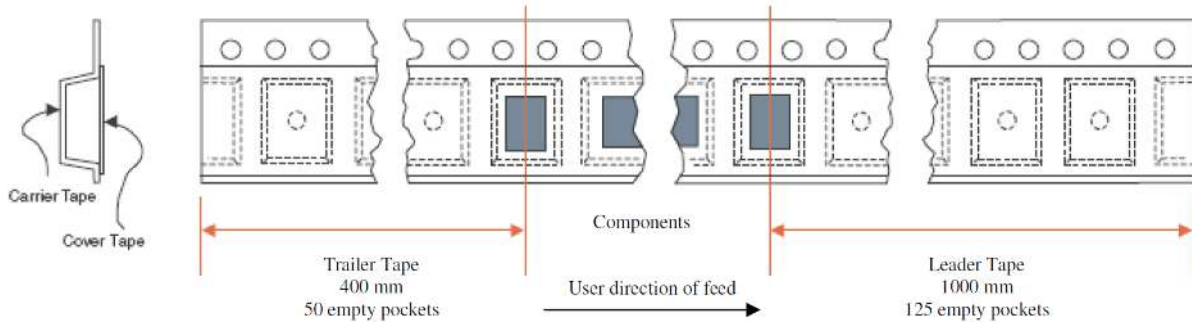

Carrier Tape Data:

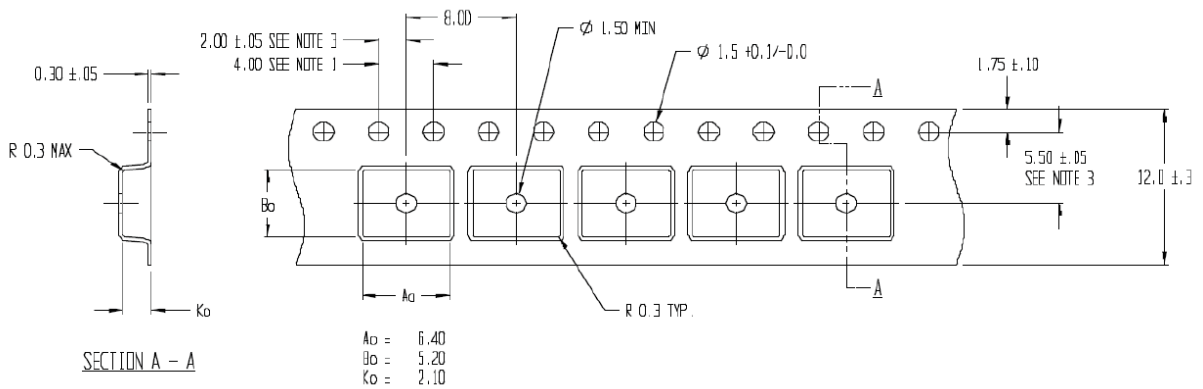

Plastic Reel Data:

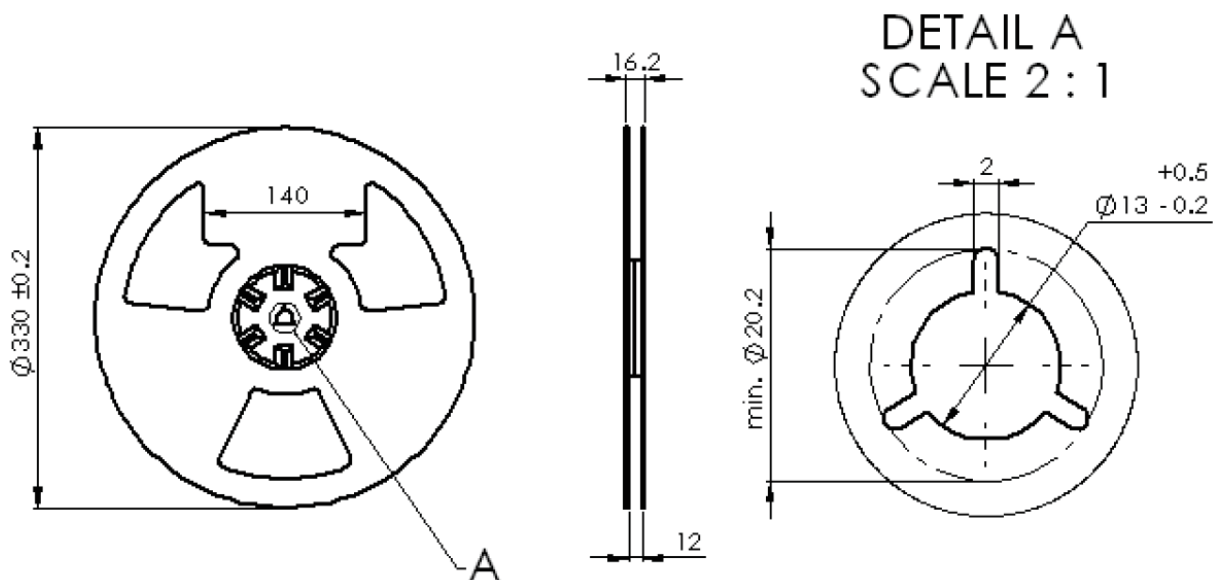

- Notes:**
- 1) 10 Sprocket hole pitch cumulative tolerance ± 0.2 mm
 - 2) Camber in compliance with EIA 481
 - 3) Pocket position relative to sprocket hole measured as true position of pocket, not pocket hole.

Soldering requirements

MSL3, 260 °C - IPC/JEDEC J-STD-020

Ordering information

Item number	Description	Package type	Package quantity
G2.05.14.002.0	GO 12-SME/SP2	Reel	3000
G2.05.14.102.0	GO 12-SME/SP2 KIT 5P	Blister	5
G2.05.14.302.0	GO 12-SME/SP2 SET OF 50 PCS	ESD Bag	50
G2.05.17.002.0	GO 20-SME/SP2	Reel	3000
G2.05.17.102.0	GO 20-SME/SP2 KIT 5P	Blister	5
G2.05.17.302.0	GO 20-SME/SP2 SET OF 50 PCS	ESD Bag	50